



**INVERTER  
ARC  
WELDER**

**MODEL LS300 CC**

- **STICK**
- **TIG - LIFT START**

**OPERATING MANUAL**

# TABLE OF CONTENTS

---

<b>1.0 GENERAL INFORMATION .....</b>	<b>2</b>
1.01 Notes, Cautions and Warnings .....	2
1.02 Important Safety Precautions .....	3
1.03 Publications .....	6
1.04 Note, Attention et Avertissement .....	7
1.05 Precautions De Securite Importantes.....	8
1.06 Documents De Reference.....	11
1.07 Declaration of Conformity .....	12
1.08 Statement of Warranty .....	13
<b>2.0 INTRODUCTION &amp; DESCRIPTION .....</b>	<b>15</b>
2.01 Description .....	15
2.02 Functional Block Diagrams .....	16
2.03 Transporting Methods.....	17
2.04 Electrical Input Connections .....	17
2.05 Specifications.....	20
2.06 Duty Cycle .....	21
<b>3.0 OPERATOR CONTROLS .....</b>	<b>22</b>
3.01 LS Front & Rear Panels .....	22
3.02 Setup for Operation .....	24
Shielded Metal Arc Welding (SMAW) .....	25
Gas Tungsten Arc Welding (GTAW) Lift Start .....	26
<b>4.0 BASIC TROUBLESHOOTING .....</b>	<b>29</b>
4.01 Common Welding Operation Faults .....	29
4.02 Specific Problems .....	29
4.03 Remote 8-Pin Connections .....	33
<b>APPENDIX A – ACCESSORIES .....</b>	<b>34</b>
<b>APPENDIX B – INTERCONNECTION DIAGRAMS.....</b>	<b>37</b>

**WARNING**

Read and understand this entire Operating Manual and your employer's safety practices before installing, operating, or servicing the equipment.

**WARNING**

While the information contained in this Operating Manual represents our best judgement, Thermal Dynamics Corporation assumes no liability for its use.

Thermal Arc Models LS300 CC Welder  
Operating Manual Number 0-2504

Published by:  
Thermal Dynamics Corporation  
Industrial Park No. 2  
West Lebanon, New Hampshire, USA 03784  
(603) 298-5711

Copyright 1997 by  
Thermal Dynamics Corporation

All rights reserved.

Reproduction of this work, in whole or in part, without written permission of the publisher is prohibited.

The publisher does not assume and hereby disclaims any liability to any party for any loss or damage caused by any error or omission in this Operating Manual, whether such error results from negligence, accident, or any other cause.

Printed in the United States of America

July 1, 1997

# 1.0 GENERAL INFORMATION

---

## 1.01 NOTES, CAUTIONS AND WARNINGS

Throughout this manual, notes, cautions, and warnings are used to highlight important information. These highlights are categorized as follows:

**NOTE**

An operation, procedure, or background information which requires additional emphasis or is helpful in efficient operation of the system.

**CAUTION**

A procedure which, if not properly followed, may cause damage to the equipment.



**WARNING**

A procedure which, if not properly followed, may cause injury to the operator or others in the operating area.



## WARNING

### 1.02 IMPORTANT SAFETY PRECAUTIONS

#### OPERATION AND MAINTENANCE OF PLASMA ARC EQUIPMENT CAN BE DANGEROUS AND HAZARDOUS TO YOUR HEALTH.

To prevent possible injury, read, understand and follow all warnings, safety precautions and instructions before using the equipment. Call 1-603-298-5711 or your local distributor if you have any questions.

#### GASES AND FUMES



Gases and fumes produced during the plasma cutting process can be dangerous and hazardous to your health.

- Keep all fumes and gases from the breathing area. Keep your head out of the welding fume plume.
- Use an air-supplied respirator if ventilation is not adequate to remove all fumes and gases.
- The kinds of fumes and gases from the plasma arc depend on the kind of metal being used, coatings on the metal, and the different processes. You must be very careful when cutting or welding any metals which may contain one or more of the following:

Antimony	Chromium	Mercury
Arsenic	Cobalt	Nickel
Barium	Copper	Selenium
Beryllium	Lead	Silver
Cadmium	Manganese	Vanadium

- Always read the Material Safety Data Sheets (MSDS) that should be supplied with the material you are using. These MSDSs will give you the information regarding the kind and amount of fumes and gases that may be dangerous to your health.
- For information on how to test for fumes and gases in your workplace, refer to item 1 in the Publications Section in this manual.
- Use special equipment, such as water or down draft cutting tables, to capture fumes and gases.
- Do not use the plasma torch in an area where combustible or explosive gases or materials are located.
- Phosgene, a toxic gas, is generated from the vapors of chlorinated solvents and cleansers. Remove all sources of these vapors.

# IMPORTANT SAFETY PRECAUTIONS (CONTINUED)

---

## ELECTRIC SHOCK



Electric Shock can injure or kill. The plasma arc process uses and produces high voltage electrical energy. This electric energy can cause severe or fatal shock to the operator or others in the workplace.

- Never touch any parts that are electrically “live” or “hot.”
- Wear dry gloves and clothing. Insulate yourself from the work piece or other parts of the welding circuit.
- Repair or replace all worn or damaged parts.
- Extra care must be taken when the workplace is moist or damp.
- Install and maintain equipment according to NEC code, refer to item 4 in the Publications section of this manual.
- Disconnect power source before performing any service or repairs.
- Read and follow all the instructions in the Operating Manual.

## FIRE AND EXPLOSION



Fire and explosion can be caused by hot slag, sparks, or the plasma arc.

- Be sure there is no combustible or flammable material in the workplace. Any material that cannot be removed must be protected.
- Ventilate all flammable or explosive vapors from the workplace.
- Do not cut or weld on containers that may have held combustibles.
- Provide a fire watch when working in an area where fire hazards may exist.
- Hydrogen gas may be formed and trapped under aluminum workpieces when they are cut underwater or while using a water table. DO NOT cut aluminum alloys underwater or on a water table unless the hydrogen gas can be eliminated or dissipated. Trapped hydrogen gas that is ignited will cause an explosion.

## NOISE



Noise can cause permanent hearing loss. Plasma arc processes can cause noise levels to exceed safe limits. You must protect your ears from loud noise to prevent permanent loss of hearing.

- To protect your hearing from loud noise, wear protective ear plugs and/or ear muffs. Protect others in the workplace.
- Noise levels should be measured to be sure the decibels (sound) do not exceed safe levels.
- For information on how to test for noise, see item 1 in the Publications section of this manual.

## IMPORTANT SAFETY PRECAUTIONS (CONTINUED)

---

### PLASMA ARC RAYS



Plasma Arc Rays can injure your eyes and burn your skin. The plasma arc process produces very bright ultra violet and infra red light. These arc rays will damage your eyes and burn your skin if you are not properly protected.

- To protect your eyes, always wear a welding helmet or shield. Also always wear safety glasses with side shields, goggles or other protective eye wear.
- Wear welding gloves and suitable clothing to protect your skin from the arc rays and sparks.
- Keep helmet and safety glasses in good condition. Replace lenses when cracked, chipped or dirty.
- Protect others in the work area from the arc rays. Use protective booths, screens or shields.
- Use the shade of lens as recommended in the Operating Manual.

## 1.03 PUBLICATIONS

---

Refer to the following standards or their latest revisions for more information:

1. OSHA, SAFETY AND HEALTH STANDARDS, 29CFR 1910, obtainable from the Superintendent of Documents, U.S. Government Printing Office, Washington, D.C. 20402
2. ANSI Standard Z49.1, SAFETY IN WELDING AND CUTTING, obtainable from the American Welding Society, 550 N.W. LeJeune Rd, Miami, FL 33126
3. NIOSH, SAFETY AND HEALTH IN ARC WELDING AND GAS WELDING AND CUTTING, obtainable from the Superintendent of Documents, U.S. Government Printing Office, Washington, D.C. 20402
4. ANSI Standard Z87.1, SAFE PRACTICES FOR OCCUPATION AND EDUCATIONAL EYE AND FACE PROTECTION, obtainable from American National Standards Institute, 1430 Broadway, New York, NY 10018
5. ANSI Standard Z41.1, STANDARD FOR MEN'S SAFETY-TOE FOOTWEAR, obtainable from the American National Standards Institute, 1430 Broadway, New York, NY 10018
6. ANSI Standard Z49.2, FIRE PREVENTION IN THE USE OF CUTTING AND WELDING PROCESSES, obtainable from American National Standards Institute, 1430 Broadway, New York, NY 10018
7. AWS Standard A6.0, WELDING AND CUTTING CONTAINERS WHICH HAVE HELD COMBUSTIBLES, obtainable from American Welding Society, 550 N.W. LeJeune Rd, Miami, FL 33126
8. NFPA Standard 51, OXYGEN-FUEL GAS SYSTEMS FOR WELDING, CUTTING AND ALLIED PROCESSES, obtainable from the National Fire Protection Association, Batterymarch Park, Quincy, MA 02269
9. NFPA Standard 70, NATIONAL ELECTRICAL CODE, obtainable from the National Fire Protection Association, Batterymarch Park, Quincy, MA 02269
10. NFPA Standard 51B, CUTTING AND WELDING PROCESSES, obtainable from the National Fire Protection Association, Batterymarch Park, Quincy, MA 02269
11. CGA Pamphlet P-1, SAFE HANDLING OF COMPRESSED GASES IN CYLINDERS, obtainable from the Compressed Gas Association, 1235 Jefferson Davis Highway, Suite 501, Arlington, VA 22202
12. CSA Standard W117.2, CODE FOR SAFETY IN WELDING AND CUTTING, obtainable from the Canadian Standards Association, Standards Sales, 178 Rexdale Boulevard, Rexdale, Ontario, Canada M9W 1R3
13. NWSA booklet, WELDING SAFETY BIBLIOGRAPHY obtainable from the National Welding Supply Association, 1900 Arch Street, Philadelphia, PA 19103
14. American Welding Society Standard AWSF4.1, RECOMMENDED SAFE PRACTICES FOR THE PREPARATION FOR WELDING AND CUTTING OF CONTAINERS AND PIPING THAT HAVE HELD HAZARDOUS SUBSTANCES, obtainable from the American Welding Society, 550 N.W. LeJeune Rd, Miami, FL 33126
15. ANSI Standard Z88.2, PRACTICE FOR RESPIRATORY PROTECTION, obtainable from American National Standards Institute, 1430 Broadway, New York, NY 10018



## 1.04 NOTE, ATTENTION ET AVERTISSEMENT

---

Dans ce manuel, les mots “note,” “attention,” et “avertissement” sont utilisés pour mettre en relief des informations à caractère important. Ces mises en relief sont classifiées comme suit :

### NOTE

Toute opération, procédure ou renseignement général sur lequel il importe d’insister davantage ou qui contribue à l’efficacité de fonctionnement du système.

### ATTENTION

Toute procédure pouvant résulter l’endommagement du matériel en cas de non-respect de la procédure en question.

### AVERTISSEMENT



Toute procédure pouvant provoquer des blessures de l’opérateur ou des autres personnes se trouvant dans la zone de travail en cas de non-respect de la procédure en question.



## AVERTISSEMENT

### 1.05 PRECAUTIONS DE SECURITE IMPORTANTES

#### L'OPÉRATION ET LA MAINTENANCE DU MATÉRIEL DE SOUDAGE À L'ARC AU JET DE PLASMA PEUVENT PRÉSENTER DES RISQUES ET DES DANGERS DE SANTÉ.

Il faut communiquer aux opérateurs et au personnel TOUS les dangers possibles. Afin d'éviter les blessures possibles, lisez, comprenez et suivez tous les avertissements, toutes les précautions de sécurité et toutes les consignes avant d'utiliser le matériel. Composez le + 603-298-5711 ou votre distributeur local si vous avez des questions.

#### FUMÉE et GAZ



La fumée et les gaz produits par le procédé de jet de plasma peuvent présenter des risques et des dangers de santé.

- Eloignez toute fumée et gaz de votre zone de respiration. Gardez votre tête hors de la plume de fumée provenant du chalumeau.
- Utilisez un appareil respiratoire à alimentation en air si l'aération fournie ne permet pas d'éliminer la fumée et les gaz.
- Les sortes de gaz et de fumée provenant de l'arc de plasma dépendent du genre de métal utilisé, des revêtements se trouvant sur le métal et des différents procédés. Vous devez prendre soin lorsque vous coupez ou soudez tout métal pouvant contenir un ou plusieurs des éléments suivants:

antimoine	cadmium	mercure
argent	chrome	nickel
arsenic	cobalt	plomb
baryum	cuiivre	sélénium
béryllium	manganèse	vanadium
- Lisez toujours les fiches de données sur la sécurité des matières (sigle américain "MSDS"); celles-ci devraient être fournies avec le matériel que vous utilisez. Les MSDS contiennent des renseignements quant à la quantité et la nature de la fumée et des gaz pouvant poser des dangers de santé.
- Pour des informations sur la manière de tester la fumée et les gaz de votre lieu de travail, consultez l'article 1 et les documents cités à la page 11.
- Utilisez un équipement spécial tel que des tables de coupe à débit d'eau ou à courant descendant pour capter la fumée et les gaz.
- N'utilisez pas le chalumeau au jet de plasma dans une zone où se trouvent des matières ou des gaz combustibles ou explosifs.
- Le phosgène, un gaz toxique, est généré par la fumée provenant des solvants et des produits de nettoyage chlorés. Éliminez toute source de telle fumée.

# PRECAUTIONS DE SECURITE IMPORTANTES

---

## CHOC ELECTRIQUE



Les chocs électriques peuvent blesser ou même tuer. Le procédé au jet de plasma requiert et produit de l'énergie électrique haute tension. Cette énergie électrique peut produire des chocs graves, voire mortels, pour l'opérateur et les autres personnes sur le lieu de travail.

- Ne touchez jamais une pièce "sous tension" ou "vive"; portez des gants et des vêtements secs. Isolez-vous de la pièce de travail ou des autres parties du circuit de soudage.
- Réparez ou remplacez toute pièce usée ou endommagée.
- Prenez des soins particuliers lorsque la zone de travail est humide ou moite.
- Montez et maintenez le matériel conformément au Code électrique national des Etats-Unis. (Voir la page 6, article 9.)
- Débranchez l'alimentation électrique avant tout travail d'entretien ou de réparation.
- Lisez et respectez toutes les consignes du Manuel de consignes.

## INCENDIE ET EXPLOSION



Les incendies et les explosions peuvent résulter des scories chaudes, des étincelles ou de l'arc de plasma. Le procédé à l'arc de plasma produit du métal, des étincelles, des scories chaudes pouvant mettre le feu aux matières combustibles ou provoquer l'explosion de fumées inflammables.

- Soyez certain qu'aucune matière combustible ou inflammable ne se trouve sur le lieu de travail. Protégez toute telle matière qu'il est impossible de retirer de la zone de travail.
- Procurez une bonne aération de toutes les fumées inflammables ou explosives.
- Ne coupez pas et ne soudez pas les conteneurs ayant pu renfermer des matières combustibles.
- Prévoyez une veille d'incendie lors de tout travail dans une zone présentant des dangers d'incendie.
- Le gas hydrogène peut se former ou s'accumuler sous les pièces de travail en aluminium lors'quelles sont coupées sous l'eau ou sur une table d'eau. NE PAS couper les alliages en aluminium sous l'eau ou sur une table d'eau à mains que le gas hydrogène peut s'échapper ou se dissiper. Le gas hydrogène accumulé explosera si enflammé.

# PRECAUTIONS DE SECURITE IMPORTANTES

---

## RAYONS D'ARC DE PLASMA



Les rayons provenant de l'arc de plasma peuvent blesser vos yeux et brûler votre peau. Le procédé à l'arc de plasma produit une lumière infra-rouge et des rayons ultra-violet très forts. Ces rayons d'arc nuiront à vos yeux et brûleront votre peau si vous ne vous protégez pas correctement.

- Pour protéger vos yeux, portez toujours un casque ou un écran de soudeur. Portez toujours des lunettes de sécurité munies de parois latérales ou des lunettes de protection ou une autre sorte de protection oculaire.



- Portez des gants de soudeur et un vêtement protecteur approprié pour protéger votre peau contre les étincelles et les rayons de l'arc.

- Maintenez votre casque et vos lunettes de protection en bon état. Remplacez toute lentille sale ou comportant fissure ou rognure.

- Protégez les autres personnes se trouvant sur la zone de travail contre les rayons de l'arc en fournissant des cabines ou des écrans de protection.

- Respectez le teint de lentille recommandé dans le manuel de consignes.

## BRUIT

Le bruit peut provoquer une perte permanente de l'ouïe. Les procédés de soudage à l'arc de plasma peuvent provoquer des niveaux sonores supérieurs aux limites normalement acceptables. Vous devez vous protéger les oreilles contre les bruits forts afin d'éviter une perte permanente de l'ouïe.

- Pour protéger votre ouïe contre les bruits forts, portez des tampons protecteurs et/ou des protections auriculaires. Protégez également les autres personnes se trouvant sur le lieu de travail.

- Il faut mesurer les niveaux sonores afin d'assurer que les décibels (le bruit) ne dépassent pas les niveaux sûrs.

- Pour des renseignements sur la manière de tester le bruit, consultez l'article 1, page 11.

## 1.06 DOCUMENTS DE REFERENCE

---

Consultez les normes suivantes ou les révisions les plus récentes ayant été faites à celles-ci pour de plus amples renseignements :

1. OSHA, NORMES DE SÉCURITÉ DU TRAVAIL ET DE PROTECTION DE LA SANTÉ, 29CFR 1910, disponible auprès du Superintendent of Documents, U.S. Government Printing Office, Washington, D.C. 20402
2. Norme ANSI Z49.1, LA SÉCURITÉ DES OPÉRATIONS DE COUPE ET DE SOUDAGE, disponible auprès de la Société Américaine de Soudage (American Welding Society), 550 N.W. LeJeune Rd., Miami, FL 33126
3. NIOSH, LA SÉCURITÉ ET LA SANTÉ LORS DES OPÉRATIONS DE COUPE ET DE SOUDAGE À L'ARC ET AU GAZ, disponible auprès du Superintendent of Documents, U.S. Government Printing Office, Washington, D.C. 20402
4. Norme ANSI Z87.1, PRATIQUES SURES POUR LA PROTECTION DES YEUX ET DU VISAGE AU TRAVAIL ET DANS LES ECOLES, disponible de l'Institut Américain des Normes Nationales (American National Standards Institute), 1430 Broadway, New York, NY 10018
5. Norme ANSI Z41.1, NORMES POUR LES CHAUSSURES PROTECTRICES, disponible auprès de l'American National Standards Institute, 1430 Broadway, New York, NY 10018
6. Norme ANSI Z49.2, PRÉVENTION DES INCENDIES LORS DE L'EMPLOI DE PROCÉDÉS DE COUPE ET DE SOUDAGE, disponible auprès de l'American National Standards Institute, 1430 Broadway, New York, NY 10018
7. Norme A6.0 de l'Association Américaine du Soudage (AWS), LE SOUDAGE ET LA COUPE DE CONTENEURS AYANT RENFERMÉ DES PRODUITS COMBUSTIBLES, disponible auprès de la American Welding Society, 550 N.W. LeJeune Rd., Miami, FL 33126
8. Norme 51 de l'Association Américaine pour la Protection contre les Incendies (NFPA), LES SYSTEMES À GAZ AVEC ALIMENTATION EN OXYGENE POUR LE SOUDAGE, LA COUPE ET LES PROCÉDÉS ASSOCIÉS, disponible auprès de la National Fire Protection Association, Batterymarch Park, Quincy, MA 02269
9. Norme 70 de la NFPA, CODE ELECTRIQUE NATIONAL, disponible auprès de la National Fire Protection Association, Batterymarch Park, Quincy, MA 02269
10. Norme 51B de la NFPA, LES PROCÉDÉS DE COUPE ET DE SOUDAGE, disponible auprès de la National Fire Protection Association, Batterymarch Park, Quincy, MA 02269
11. Brochure GCA P-1, LA MANIPULATION SANS RISQUE DES GAZ COMPRIMÉS EN CYLINDRES, disponible auprès de l'Association des Gaz Comprimés (Compressed Gas Association), 1235 Jefferson Davis Highway, Suite 501, Arlington, VA 22202
12. Norme CSA W117.2, CODE DE SÉCURITÉ POUR LE SOUDAGE ET LA COUPE, disponible auprès de l'Association des Normes Canadiennes, Standards Sales, 178 Rexdale Boulevard, Rexdale, Ontario, Canada, M9W 1R3
13. ivret NWSA, BIBLIOGRAPHIE SUR LA SÉCURITÉ DU SOUDAGE, disponible auprès de l'Association Nationale de Fournitures de Soudage (National Welding Supply Association), 1900 Arch Street, Philadelphia, PA 19103
14. Norme AWSF4.1 de l'Association Américaine de Soudage, RECOMMANDATIONS DE PRATIQUES SURES POUR LA PRÉPARATION À LA COUPE ET AU SOUDAGE DE CONTENEURS ET TUYAUX AYANT RENFERMÉ DES PRODUITS DANGEREUX , disponible auprès de la American Welding Society, 550 N.W. LeJeune Rd., Miami, FL 33126
15. Norme ANSI Z88.2, PRATIQUES DE PROTECTION RESPIRATOIRE, disponible auprès de l'American National Standards Institute, 1430 Broadway, New York, NY 10018

## 1.07 DECLARATION OF CONFORMITY

---

Manufacturer: Thermal Dynamics Corporation  
Address: Industrial Park #2  
West Lebanon, New Hampshire 03784  
USA

The equipment described in this manual conforms to all applicable aspects and regulations of the 'Low Voltage Directive' (European Council Directive 73/23/EU, as recently changed in Directive 93/63/EU) and to the National legislation for the enforcement of this Directive.

The equipment described in this manual conforms to all applicable aspects and regulations of the "EMC Directive" (European Council Directive 89/336/EEC) and to the National legislation for the enforcement of this Directive.

Serial numbers are unique with each individual piece of equipment and details description, parts used to manufacture a unit and date of manufacture.

### **National Standard and Technical Specifications**

The product is designed and manufactured to a number of standards and technical requirements among them are:

- \* CSA (Canadian Standards Association) standard C22.2 number 60-M1990 for Arc welding equipment.
- \* UL (Underwriters Laboratory) rating 94VO flammability testing for all printed-circuit boards used.
- \* CENELEC EN50199 EMC Product Standard for Arc Welding Equipment March 1995.
- \* IEC 974-1 (BS 638-PT10) (EN 60 974-1) applicable to welding equipment and associated accessories.
- \* Extensive product design verification is conducted at the manufacturing facility as part of the routine design and manufacturing process, to ensure the product is safe and performs as specified. Rigorous testing is incorporated into the manufacturing process to ensure the manufactured product meets or exceeds all design specifications.

Thermal Dynamics has been manufacturing products that perform in a safe manner for more than 30 years and will continue to achieve excellence in our area of manufacture.

Manufacturers responsible representative: David Ashworth  
Vice President & Managing Director  
Thermadyne Europe  
Chorley England.



## 1.08 STATEMENT OF WARRANTY

---

**LIMITED WARRANTY:** Thermal Dynamics Corporation (hereinafter "Thermal") warrants that its products will be free of defects in workmanship or material. Should any failure to conform to this warranty appear within the time period applicable to the Thermal products as stated below, Thermal shall, upon notification thereof and substantiation that the product has been stored, installed, operated, and maintained in accordance with Thermal's specifications, instructions, recommendations and recognized standard industry practice, and not subject to misuse, repair, neglect, alteration, or accident, correct such defects by suitable repair or replacement, at Thermal's sole option, of any components or parts of the product determined by Thermal to be defective.

THIS WARRANTY IS EXCLUSIVE AND IS IN LIEU OF ANY WARRANTY OF MERCHANTABILITY OR FITNESS FOR A PARTICULAR PURPOSE.

**LIMITATION OF LIABILITY:** Thermal shall not under any circumstances be liable for special or consequential damages, such as, but not limited to, damage or loss of purchased or replacement goods, or claims of customers of distributor (hereinafter "Purchaser") for service interruption. The remedies of the Purchaser set forth herein are exclusive and the liability of Thermal with respect to any contract, or anything done in connection therewith such as the performance or breach thereof, or from the manufacture, sale, delivery, resale, or use of any goods covered by or furnished by Thermal whether arising out of contract, negligence, strict tort, or under any warranty, or otherwise, shall not, except as expressly provided herein, exceed the price of the goods upon which such liability is based.

THIS WARRANTY BECOMES INVALID IF REPLACEMENT PARTS OR ACCESSORIES ARE USED WHICH MAY IMPAIR THE SAFETY OR PERFORMANCE OF ANY THERMAL PRODUCT.

THIS WARRANTY IS INVALID IF THE PRODUCT IS SOLD BY NON-AUTHORIZED PERSONS.

The limited warranty periods for Thermal products shall be as follows: A maximum of three (3) years from date of sale to an authorized distributor and a maximum of two (2) years from date of sale by such distributor to the Purchaser, and with the following further limitations on such two (2) year period:

<u>PAK UNITS, POWER SUPPLIES</u>	<u>PARTS</u>	<u>LABOR</u>
MAIN POWER MAGNETICS .....	2 YEARS .....	1 YEAR
ORIGINAL MAIN POWER RECTIFIER .....	2 YEARS .....	1 YEAR
CONTROL PC BOARD .....	2 YEARS .....	1 YEAR
ALL OTHER CIRCUITS AND COMPONENTS .....	1 YEAR .....	1 YEAR
INCLUDING, BUT NOT LIMITED TO, STARTING CIRCUIT, CONTACTORS, RELAYS, SOLENOIDS, PUMPS, POWER SWITCHING SEMI-CONDUCTORS		
<u>CONSOLES, CONTROL EQUIPMENT, HEAT</u> .....	1 YEAR .....	1 YEAR
<u>EXCHANGES, AND ACCESSORY EQUIPMENT</u>		
<u>TORCH AND LEADS</u> .....	180 DAYS .....	180 DAYS
<u>REPAIR/REPLACEMENT PARTS</u> .....	90 DAYS .....	90 DAYS

Warranty repairs or replacement claims under this limited warranty must be submitted by an authorized Thermal Arc® repair facility within thirty (30) days of the repair. Authorized Thermal Arc® repair facilities are authorized distributors and authorized Thermal Arc® Service Centers. No transportation costs of any kind will be paid under this warranty. Transportation charges to send products to an authorized warranty repair facility shall be the responsibility of the customer. All returned goods shall be at the customer's risk and expense. This warranty supersedes all previous Thermal warranties.

Thermal Arc® is a Registered Trademark of Thermal Dynamics.

Effective January 18, 1991





## 2.0 INTRODUCTION & DESCRIPTION

### 2.01 Description

The Thermal Arc™ Model LS300 is a single or three-phase DC arc welding power source with Constant Current (CC) output characteristics. It is available with an optional digital AMPERAGE/VOLTAGE panel meter (standard in European models).

The LS300 unit is designed for use with Shielded Metal Arc Welding (SMAW) and Gas Tungsten Arc Welding -Lift Start (GTAW) processes.

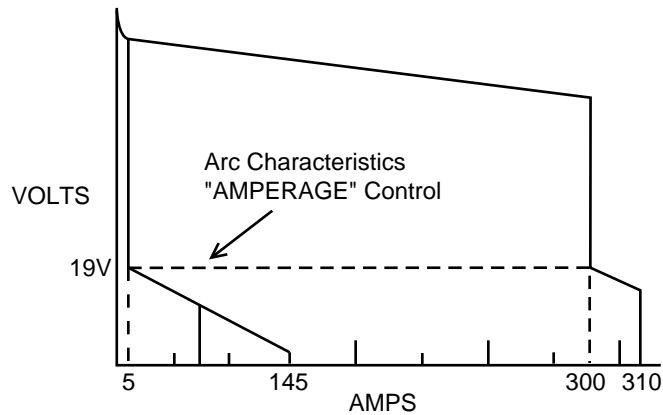

*Figure 1. LS300 model Volt-Ampere curve*

**NOTE** Volt-Ampere curves show the maximum Voltage and Amperage output capabilities of the welding power source. Curves of other settings will fall between the curves shown.

## 2.02 Functional Block Diagrams

Figure 2 illustrates the functional block diagram of the LS300 power supply.

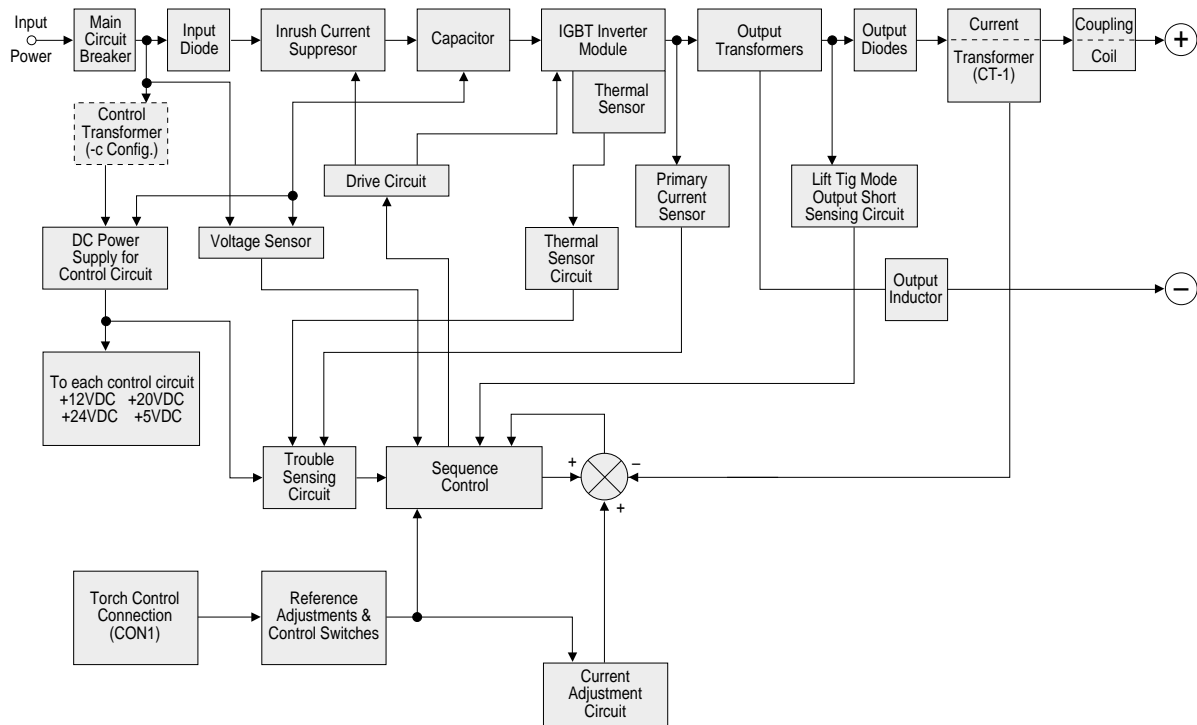

Figure 2. LS300 Model functional block diagram

## 2.03 Transporting Methods

| These units are equipped with a handle for carrying purposes.



**WARNING** ELECTRIC SHOCK can kill.

- DO NOT TOUCH live electrical parts.
- Disconnect input power conductors from de-energized supply line before moving welding power source.



**WARNING** FALLING EQUIPMENT can cause serious personal injury and equipment damage.

- Lift unit with handle on top of case.
- Use hand cart or similar device of adequate capacity.
- If using a fork lift vehicle, place and secure unit on a proper skid before transporting.

## 2.04 Electrical Input Connections



**WARNING** ELECTRIC SHOCK can kill; SIGNIFICANT DC VOLTAGE is present after removal of input power.

- DO NOT TOUCH live electrical parts.
- SHUT DOWN welding power source, disconnect input power employing lockout/tag out procedures. Lockout/tag out procedures consist of padlocking line disconnect switch in open position, removing fuses from fuse box, or shutting off and red-tagging circuit breaker or other disconnecting device.

### Electrical Input Requirements

Operate the welding power source from a single or three-phase 50/60 Hz, AC power supply. The input voltage must match one of the electrical input voltages shown on the input data label on the unit nameplate. Contact the local electric utility for information about the type of electrical service available, how proper connections should be made, and inspection required.

The line disconnect switch provides a safe and convenient means to completely remove all electrical power from the welding power supply whenever necessary to inspect or service the unit.

### NOTE

These units are equipped with a four-conductor with earth power cable that is connected at the welding power source end for single or three-phase electrical input power.

- **To operate single-phase, do not connect the RED input conductor.**
- Do not connect an input (WHITE, BLACK or RED) conductor to the ground terminal.
- Do not connect the ground (GREEN) conductor to an input line terminal.

Refer to figure 3 and:

1. Connect end of ground (GREEN) conductor to a suitable ground. Use a grounding method that complies with all applicable electrical codes.
2. Connect ends of line 1 (BLACK), line 2 (WHITE) and line 3 (RED) input conductors to a de-energized line disconnect switch.
3. Use Table 1 below as a guide to select line fuses for the disconnect switch.

**Table 1. Fuse Size Selection**

Input Power/Input Voltage	Fuse Size (Amperes)	
	Three-Phase	Single-Phase
208-230VAC	60	60
380-415 VAC	30	N/A
460 VAC	25	30

**NOTE** Fuse size is based on not more than 200 percent of the rated input amperage of the welding power source (Based on Article 630, National Electrical Code).

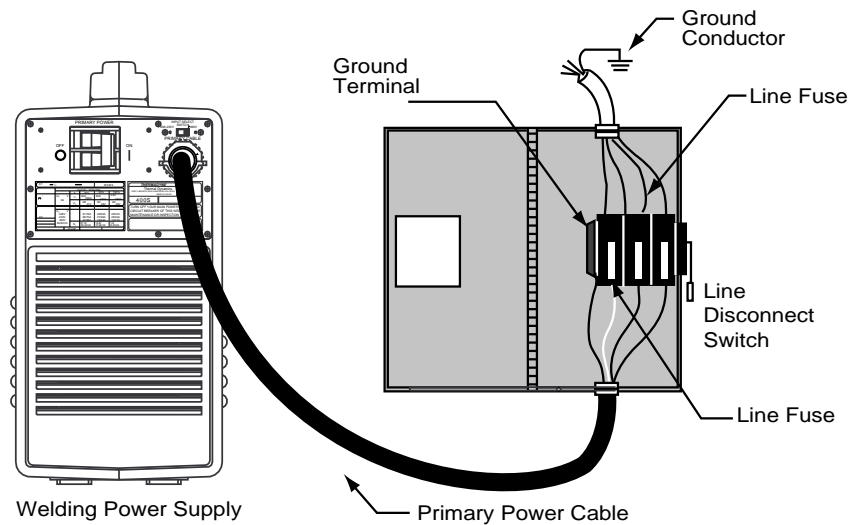

**Figure 3. Electrical input connections**

**Input Power** | Each unit incorporates an INRUSH circuit and input voltage sensing circuit. When the MAIN CIRCUIT BREAKER is turned on, the inrush circuit provides a pre-charging of the input capacitors. SCR's in the Power Control Assembly (PCA) will turn on after the input capacitors have charged to full operating voltage (after approximately 5 seconds).

**NOTE** | Note the available input power. Damage to the PCA could occur if 575VAC is applied with the INPUT SELECT switch in the 208-230V position.

- 208VAC 50/60Hz three-phase/single-phase
- 230VAC 50/60Hz three-phase/single-phase
- 460VAC 50/60Hz three-phase/single-phase
- 575VAC 50/60Hz three-phase

## 2.05 Specifications

### LS300 Models

#### Parameter

<b>Rated Output</b>		
<b>40% duty cycle</b>		
Three-phase		
Amperes		250
Volts		30
Single-phase		
Amperes		170
Volts		27
<b>25% duty cycle</b>		
Three-phase		
Amperes		300
Volts		32
Single-phase		
Amperes		210
Volts		28
<b>Output Range (Min. - Max.)</b>	<b>STICK/LIFT TIG</b>	
Amperes	5-300	
Volts	10-32	
<b>Open Circuit Voltage</b>		
230 V/460 V	64 V	
<b>Dimensions/Weight</b>		
Width	8.3 in (210 mm)	
Height	16.9 in (430 mm)	
Length	16.5 in (420 mm)	
Weight	40.7 lb (18.5 kg)	
<b>Output at No Load</b>		
	<b>Three-phase Input</b>	<b>Single-phase Input</b>
208 V	1.4 A	2.4 A
230 V	1.3 A	2.2 A
380 V	0.8 A	
400 V	0.7 A	
415 V	0.7 A	
460 V	0.6 A	1.1 A
575 V	0.5 A	
KVA		0.5
KW		0.3
<b>Output at Rated Load</b>		
	<b>Three-phase Input</b>	<b>Single-phase Input</b>
<b>25% Duty Cycle</b>		
208 V	40 A	53 A
230 V	37 A	48 A
380 V	22 A	
400 V	21 A	
415 V	20 A	
460 V	18 A	24 A
575 V	15 A	
KVA	14.6	10.9
KW	11.3	6.9
<b>40% Duty Cycle</b>	<b>Three-phase Input</b>	<b>Single -phase Input</b>
208 V	32 A	41 A
230 V	29 A	37 A
380 V	17 A	
400 V	16 A	
415 V	15 A	
460 V	14 A	19 A
575 V	11 A	
KVA	11.4	8.5
KW	8.8	5.7

## 2.06 Duty Cycle

The duty cycle of a welding power source is the percentage of a ten (10) minute period that it can be operated at a given output without causing overheating and damage to the unit. If the welding amperes decrease, the duty cycle increases. If the welding amperes are increased beyond the rated output, the duty cycle will decrease.



### WARNING

Exceeding the duty cycle ratings will cause the thermal overload protection circuit to become energized and shut down the output until the unit has cooled to normal operating temperature.

Continually exceeding the duty cycle ratings can cause damage to the welding power source.

To calculate duty cycle:

$$\text{current} = \sqrt{\frac{(\text{rated current})^2 \times (\text{rated duty cycle})}{(\text{desired duty cycle})}}$$

i.e. At the 300A rated output current, and 25% rated duty cycle, the operator wants to work on a **50% duty cycle**. The maximum allowable current draw is:

$$\text{current} = \sqrt{\frac{(300\text{A})^2 \times (.25)}{(.50)}}$$

$$\text{current} = \sqrt{90,000 \times (0.5)}$$

$$\text{current} = \sqrt{45,000}$$

$$\text{current} = 212.1\text{A}$$

## 3.0 OPERATOR CONTROLS

### 3.01 LS Front & Rear Panels

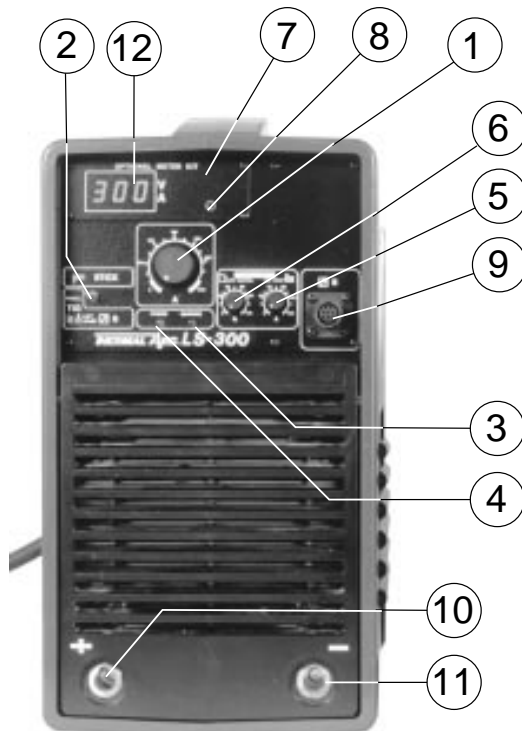

- ① **Amperage Control** - The Amperage Control selects the desired amperage within the entire range of the welding power source. Rotating this control in a clockwise direction increases the amperage output. The scale surrounding the amperage control represents approximate actual amperage values.
- ② **Process Selector Switch** - The Process Selector Switch allows the operator to select the STICK welding (SMAW) process or LIFT TIG (GTAW) process.
- ③ **Warning Indicator** - The Warning Indicator located on the front panel will become activated under the following conditions:
  - Input voltage is too low
  - Input voltage too high
  - Thermal overload
- ④ **AC Power Indicator** - The AC Power Indicator located on the front panel lights when the Primary Power Switch is in the ON position, indicating the unit is energized.
- ⑤ **Hot Start Control** - The Hot Start Control provides a variable selection of start circuit current that operates in the STICK mode. The Hot Start time is approximately 0.06 seconds in STICK. The current value is adjusted from 0 to 100 Amps over the determined weld current set by the Amperage Control. Rotating the control clockwise increases Hot Start current.
- ⑥ **ARC Control** - The Arc Control is in use in the SMAW mode only. Rotate the control clockwise to increase the short circuit current available to control the welding arc; adjust to reduce sticking of electrode to plate.
- ⑦ **Amperage/Voltage Selector Switch** - Selects digital meter display of output amperage or voltage. Part of optional meter kit, part number 10-4000.
- ⑧ **Preview Pushbutton Switch** - Allows digital meter to be used to set amperage (in TIG or STICK modes) prior to welding. Part of optional meter kit, part number 10-4000.
- ⑨ **8-Pin Receptacle** - Used for remote contactor and amperage controls.
- ⑩ **Positive Terminal** - 50mm DIN-style female receptacle.
- ⑪ **Negative Terminal** - 50mm DIN-style female receptacle.
- ⑫ **LCD Display** - Part of optional meter kit, part number 10-4000.

Figure 4. Front panel operator controls



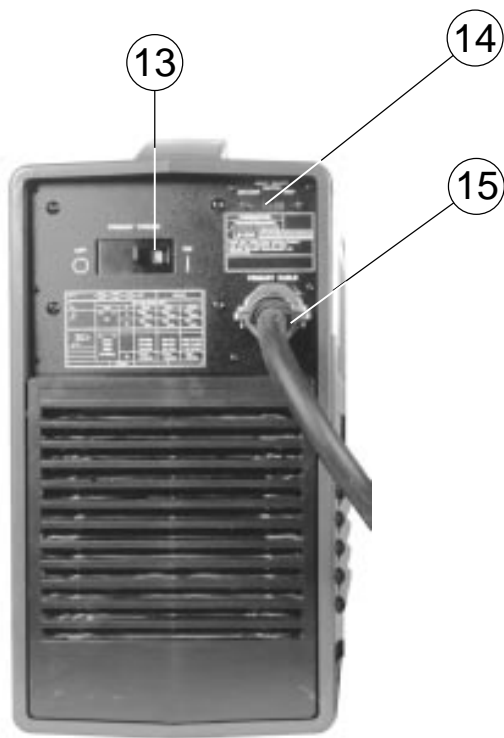

- ⑬ **Primary Power Switch** - Placing the Primary Power Switch (circuit breaker) located on the rear panel to the ON position energizes the welding power source.
- ⑭ **Voltage Selector** - Manual slide switch selects the proper input voltage range. If this slide switch is not set to the position that matches the input voltage from the electrical source the Smart Logic will inhibit welding power source turn on and the warning indicator will be illuminated. Not installed in 460V/575V units.
- ⑮ **Input Cable** - 10 feet

*Figure 5. Rear panel operator controls*

### 3.02 Setup for Operation



#### Arc Control

The ARC CONTROL provides a variable selection of short circuit amperage to suit individual welding situations when operating in the STICK welding (SMAW) mode.

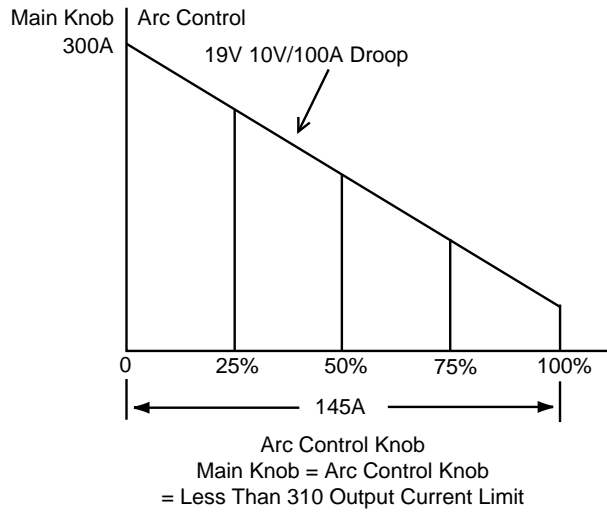

**Figure 6. Arc Control Characteristics**

## 3.02 Setup for Operation

### Shielded Metal Arc Welding (SMAW)



#### WARNING

Read and follow all safety precautions on pages 2-5 of this manual before preceding with operation.

1. Install and connect unit according to the installation instructions in section 2.04, page 17, of this manual.
2. Wear dry insulating gloves and clothing.
3. Connect work clamp to clean, bare metal on workpiece. For the majority of electrodes in use, the work clamp is connected to the GROUND or NEGATIVE output terminal.
4. Select proper electrode.
5. Refer to Operator Control section, page 22, and set the controls per the following:
  - a. PROCESS SELECTOR switch [2] to STICK position.
  - b. Rotate the AMPERAGE control [1] to output current level desired.



6. Insert electrode into electrode holder. For the majority of electrodes in use, the electrode holder is connected to the POSITIVE output terminal.
7. Wear welding helmet with proper filter lens according to ANSI Z49.1.
8. Place the PRIMARY POWER switch [13] to ON.
9. Begin welding.

#### NOTE

The Output Contactor is on when the LS300 is in the STICK mode.

## 3.02 Setup for Operation

### Gas Tungsten Arc Welding (GTAW) Lift Start



**WARNING** Read and follow all safety precautions on pages 2-5 of this manual before preceding with operation.

1. Install and connect unit according to the installation instructions in section 2.04, page 17, of this manual.
2. Select proper tungsten electrode (refer to Electrode Selection Table 2, page 28).
3. Prepare tungsten electrode and insert into torch. For the majority of electrodes in use, the electrode is connected to the NEGATIVE output terminal.
4. Wear dry insulating gloves and clothing.
5. Connect shielding gas supply to gas fitting on back panel.
6. Connect remote control device to 8-pin receptacle.

**NOTE** The maximum output that can be obtained using the remote control is set by the main current knob.

7. Connect work clamp to clean, bare metal on workpiece. For the majority of electrodes in use, the work clamp is connected to the POSITIVE output terminal.
8. Refer to the Operator Control section, page 22, and set the controls per the following:
  - a. PROCESS SELECTOR switch [2] to LIFT START Gas Tungsten Arc Welding position (GTAW).



**LIFT START  
(GTAW WITHOUT HIGH  
FREQUENCY)**

In this mode, the unit provides weld output for the Gas Tungsten Arc Welding (GTAW) process. When the process selector switch is in this position, the HOT START ARC CONTROL will not function. The unit will provide a low open circuit voltage and approximately 15 amps to the tungsten electrode when touched to the work. After the Tungsten Electrode is lifted away and the welding arc becomes established, the output current will be regulated at the current level determined by the AMPERAGE control [1].

b. Rotate the AMPERAGE control [1] to output current level desired.

8. Turn on shielding gas.

9. Wear welding helmet with proper filter lens according to ANSI Z49.1.

10. Place the PRIMARY POWER switch [13] to ON.

11. Activate remote control device.

a. In LIFT TIG mode, touch electrode to work and lift to start arc.

12. Begin welding.

**NOTES**



**WARNING**

HIGH CONCENTRATION OF SHIELDING GAS can impair health or kill. Shut off gas supply when not in use.

### 3.02 Setup for Operation

**Table 2. Electrode Selection Table**

Electrode/Diameter	Amperage Range	
	DC-Argon Electrode Negative/Straight Polarity	DC-Argon Electrode Positive/Reverse Polarity
Pure Tungsten (Green Band)		
0.010 in. (0.25mm)	1-15	—
0.020 in. (0.51mm)	5-20	—
0.040 in. (1.02mm)	15-80	—
1/16 in. (1.59mm)	70-150	10-20
3/32 in. (2.38mm)	125-225	15-20
1/8 in. (3.18mm)	225-360	25-40
5/32 in. (3.97mm)	360-450	40-55
3/16 in. (4.76mm)	450-720	55-80
1/4 in. (6.35mm)	720-950	80-125
2% Thorium Alloyed Tungsten (Red Band)		
0.010 in. (0.25mm)	1-25	—
0.020 in. (0.51mm)	15-40	—
0.040 in. (1.02mm)	25-85	—
1/16 in. (1.59mm)	50-160	10-20
3/32 in. (2.38mm)	135-235	15-30
1/8 in. (3.18mm)	250-400	25-40
5/32 in. (3.97mm)	400-500	40-55
3/16 in. (4.76mm)	500-750	55-80
1/4 in. (6.35mm)	750-1,000	80-125

**Table 3. Weld Cable Size**

	Maximum Total Cable Length in Weld Circuit							
	Under 100 ft. (Under 30m)		150 ft. (45m)	200 ft. (60m)	250 ft. (70m)	300 ft. (90m)	350 ft. (105m)	400 ft. (120m)
Duty Cycle	100-60%	60-100%			10-100%			
Welding Amperes								
100	4	4	4	3	2	1	1/0	1/0
150	3	3	2	1	1/0	2/0	3/0	3/0
200	3	2	1	1/0	2/0	3/0	4/0	4/0
250	2	1	1/0	2/0	3/0	4/0	2-2/0	2-2/0
300	1	1/0	2/0	3/0	4/0	2-2/0	2-3/0	2-3/0
400	1/0	2/0	3/0	4/0	2-2/0	2-3/0	2-4/0	2-4/0

## 4.0 BASIC TROUBLESHOOTING

---

**General** | Troubleshooting and repairing this unit is a process which should be undertaken only by those familiar with high voltage, high power electronic equipment.



### WARNING

There are extremely dangerous voltage and power levels present inside this unit. Do not attempt to diagnose or repair unless you have had training in power electronics measurement and troubleshooting techniques.

### 4.01 Common Welding Operation Faults

The following are some of the more common operating faults that occur during welding operations:

#### A. Power

- Main power not connected
- Main power not turned on
- MAIN CIRCUIT BREAKER set on the OFF position
- INPUT SELECTOR (Easy Link) Switch in wrong position

#### B. Poor Weld

- Wrong polarity
- Wrong electrode used
- Electrode not properly prepared
- Incorrect welding amperage setting
- Speed too slow or too fast
- Incorrect switch settings for intended operation
- Poor weld output connection(s)

#### C. Remote Operation

- Incorrect contactor switch settings
- Remote not connected

If the problem is not resolved after checking the above, the following guide may suggest more specific items to check given the faulty operating symptom(s) you are experiencing.

### 4.02 Specific Problems

#### How to Use This Guide

The following information is a guide to help you determine the most likely causes for various symptoms.

This guide is set up in the following manner:

#### A. Symptom (Bold Type)

Any special instructions (Text Type)

##### 1. Cause (Italic Type)

a. Check/Remedy (Text Type)

Locate your symptom, check the cause(s) (the simplest or most likely is listed first), then perform the remedy given. Repair as needed being sure to verify that the unit is fully operational after any repairs.

### **A. No Weld Output; Unit is Completely Inoperative**

1. *Line disconnect switch is in OFF position*
  - a. Place line disconnect switch in ON position.
2. *Line fuse(s) open*
  - a. Check and replace line fuse(s).
3. *Improper electrical input connections*
  - a. See Section 2.04 Electrical Input Requirements, page 17, for proper input connections.
4. *MAIN CIRCUIT BREAKER in OFF position*
  - a. Check and reset MAIN CIRCUIT BREAKER if necessary.
5. *INPUT SELECTOR (Easy Link) switch is set to incorrect position for applied input voltage*
  - a. Verify primary source voltage and set INPUT SELECT switch to correct setting.

### **B. WARNING Indicator is ON**

1. *Unit is in thermal shutdown mode*
  - a. Allow cooling period of approximately five (5) minutes with the power ON. Duty cycle should be reviewed. To reset the WARNING indicator, the power supply must be turned OFF, then ON again.
2. *Input voltage fluctuation causing protection circuits to activate*
  - a. Monitor input power for spikes and high voltage condition. Most power utilities will monitor and verify line voltage.
  - b. Measure input voltage and verify that it matches the INPUT SELECTOR (Easy Link) switch setting. The length of the input power cable must be considered, as there will be a considerable voltage drop along its length.

### **C. Erratic or Improper Weld Output**

1. *Loose welding cable connections*
  - a. Tighten all welding cable connections.
2. *Incorrect welding cable size*
  - a. Use proper size and type of cable (see Table 2, page 28).
3. *Improper input connections*
  - a. Refer to Section 2.04 Electrical Input Requirements, page 17.
4. *Poor electrode condition*
  - a. Replace electrode.
5. *If using a wire feeder, ensure that the wire is feeding at a consistent rate*
  - a. Adjust wire feeder.
6. *If in GTAW mode, check the condition of the tungsten electrode*
  - a. Use the recommended 2% Thoriated tungsten.
7. *In GTAW mode, incorrect argon gas flow*
  - a. Verify that argon gas flow is approximately 12-15 SCFH.
8. *Incorrectly set PROCESS SELECTOR switch*
  - a. Verify the PROCESS SELECTOR switch is set to match the type of welding process being conducted.
9. *Wrong welding polarity*
  - a. Verify output torch connections.



#### **D. Wandering Arc, Poor Control of Arc Direction**

1. *Wrong size tungsten electrode, typically larger than recommended*
  - a. Use proper size electrode for amperage selected (see Table 2, page 28).
2. *Improperly prepared tungsten electrode*
  - a. Prepare tungsten properly.
3. *Gas flow rate too high*
  - a. Reduce flow rate.
4. *Drafts blowing shielding gas away from tungsten electrode*
  - a. Shield weld zone from drafts and check condition of tungsten electrode.
5. *Water in torch*
  - a. Refer to torch parts list for part(s) requiring replacement and repair torch as necessary.

#### **E. Green AC POWER Indicator OFF; Fan Not Operating**

1. *Input line disconnect switch in OFF position*
  - a. Place input line disconnect switch to ON position.
2. *Power supply MAIN CIRCUIT BREAKER (MCB) in OFF position*
  - a. Place MCB to ON position.
3. *Input line breaker tripped/fuses blown*
  - a. Reset MCB; check primary supply breaker or fuses and replace if necessary.

#### **NOTE**

Verify that for single-phase operation, the RED input line is not connected.

4. *Open conductor in input power line*
  - a. Check continuity and replace if necessary.

#### **F. Red WARNING Indicator ON; No Weld Output**

1. *Input voltage fluctuation causing protection circuits to activate*
  - a. Monitor input power for spikes and high voltage condition. Most power utilities will monitor and verify line voltage.
2. *Thermal sensor TH1 open (thermal shutdown)*
  - a. Allow the unit to cool for five minutes before turning the power supply ON.

#### **G. No Weld or Output; Fan Operating; WARNING Indicator OFF**

1. *Faulty Remote Control Device*
  - a. Connect a jumper between pins 2 and 3 of the REMOTE 8 receptacle for contactor closure. If amperage and voltage can be adjusted with front panel controls, repair or replace remote control device.
2. *Line voltage is too high*
  - a. Verify that input voltage matches setting on rear panel INPUT SELECTOR switch.

#### **H. Low or Maximum Weld Output With No Control**

1. *Faulty remote control device*
  - a. Connect a jumper between pins 2 and 3 of the REMOTE 8 receptacle for contactor closure. If amperage and voltage can be adjusted with front panel controls, repair or replace remote control device.

**I. Limited Weld Output**

*1. Poor primary input voltage*

- a. Check primary input voltage is within  $\pm 10\%$  of nominal voltage, i.e. 230VAC  $\pm 10\%$ .

**J. Erratic or Improper Weld Output**

*1. Loose welding cable connections*

- a. Tighten all welding cable connections.

*2. Improper setup*

- a. Check for proper connection of input power.

*3. Faulty Remote Device*

- a. Check all remote devices and repair or replace if necessary.

**K. No Weld Output; Fan Not Operating; WARNING Indicator OFF**

*1. Line voltage too low*

- a. Verify that input voltage matches setting on rear panel INPUT SELECTOR switch.

*2. Incompatible remote control device*

- a. Verify remote device wiring matches receptacle.

*3. Faulty remote control device*

- a. Jumper output contractor. If unit produces output, the remote device is faulty.

## 4.03 REMOTE 8-Pin Connections

The REMOTE 8-Pin receptacle is used to connect any of the following equipment to the welding power source circuitry:

- Remote Hand Pendant
- Remote Foot Control
- Remote Contactor Control
- Remote Amperage Control

To make connections, align keyway, insert plug, and rotate threaded collar fully clockwise. The socket information is included in the event the supplied cord is not suitable and it is necessary to wire a plug or cord to interface with the REMOTE 8-Pin receptacle.

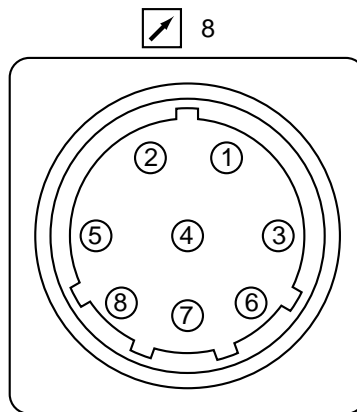

Socket	Function
1	Chassis common
2	Remote contactor control when contact closure is provided between sockets 2 and 3 (GND)
3	Remote contactor control when contact closure is provided between sockets 2 and 3 (+24 V DC)
4	Remote amperage control when contact closure is provided between sockets 4 and 8 (+12 V DC)
5	Amperage remote control (MINIMUM); PC board common; use as return for remote control inputs/outputs
6	Amperage remote control (MAXIMUM) input command signal; +4 volts for maximum
7	Remote amperage reference signal (WIPER); 0 volts to +4 volts (peak current set by main rheostat)
8	Remote amperage control when contact closure is provided between sockets 4 and 8 (SIGNAL)

*Figure 7. REMOTE 8-Pin Connections*

## APPENDIX A - ACCESSORIES

REMOTE CONTROL	CAT. NO	ARC CURRENT ON/OFF CONTROL	LENGTH	CONNECTORS	APPLICABLE TORCH HANDLE
<b>Miscellaneous Accessories</b>					
Digital Meter Kit	10-4000	Current and Voltage display with hold feature			
Adapter	10-4003	X	6"/150cm	8-Pin (Male & 14-Pin (Female)	All
Dinse Connector	10-2020	50mm Dinse-style plug - Male for additional torches/electrode holders			
<b>Remote Control</b>					
Torch Switch	10-4006	X	15'/4.6m	8-Pin (Male)	N/A
Torch Switch	10-4007	X	25'/7.6m	8-Pin (Male)	N/A
Torch Switch	10-4008	X	15'/4.6m	8-Pin (Male)	5/8" - 7/8"/16mm-22mm
Torch Switch	10-4009	X	15'/4.6m	8-Pin (Male)	7/8" - 1 1/8"/22mm-29mm
Torch Switch	10-4010	X	15'/4.6m	8-Pin (Male)	1 1/8" - 1 3/8"/29mm-35mm
Torch Switch	10-4011	X	25'/7.6m	8-Pin (Male)	5/8" - 7/8"/16mm-22mm
Torch Switch	10-4012	X	25'/7.6m	8-Pin (Male)	7/8" - 1 1/8"/22mm-29mm
Torch Switch	10-4013	X	25'/7.6m	8-Pin (Male)	1 1/8" - 1 3/8"/29mm-35mm
Hand Pendant	10-4014	X	25'/7.6m	8-Pin (Male)	N/A
Foot Control	10-4015	X	15'/4.6m	8-Pin (Male)	N/A
Foot Control	10-4016	X	25'/7.6m	8-Pin (Male)	N/A
<b>Extension Cables for Remote Controls</b>					
Ext. Cable	10-4017	X	3'/.9m	8-Pin (Male) & 8-Pin (Female)	N/A
Ext. Cable	10-4018	X	15'/4.6m	8-Pin (Male) & 8-Pin (Female)	N/A
Ext. Cable	10-4019	X	25'/7.6m	8-Pin (Male) & 8-Pin (Female)	N/A
Ext. Cable	10-4020	X	50'/15.2m	8-Pin (Male) & 8-Pin (Female)	N/A
Ext. Cable	10-4021	X	75'/22.8m	8-Pin (Male) & 8-Pin (Female)	N/A
Ext. Cable	10-4022	X	100'/30.4m	8-Pin (Male) & 8-Pin (Female)	N/A

<b>Miscellaneous Accessories (Kits are provided assembled ready to install)</b>		
<b>Item</b>	<b>Cat. No.</b>	<b>Description</b>
TIG Kit	10-4080	Includes: Arcair BG-26V-12 TIG Torch w/ accessory kit, Victor HRF1425-580 regulator, Ground lapm w/ 12ft. cable and 50mm Dinse Connector attached
STICK Kit	10-4082	Includes: Electrode Holder w/ 15ft. cable and 50mm Dinse-style Connector attached Ground Clamp w/ 12ft. cable and 50mm Dinse-style Connector attached
Dinse TIG Block	10-2023	Air Cooled (#26 style) 7/8-14 R.H.
Dinse TIG Block	10-2028	Air Coled (#17 style) 3/8-24 R.H.
Dinse TIG Block	10-2027	Air Cooled (#18 style) 7/8-14 L.H.
Adapter	10-4003	8-Pin (Male) to 14-Pin (Female)



## **APPENDIX B – INTERCONNECTION DIAGRAMS**

---

The following pages contain the interconnection diagrams for all LS300, models in current production, to aid in the identification of replacement parts.

# LS300 - 230/460V Interconnection Diagram

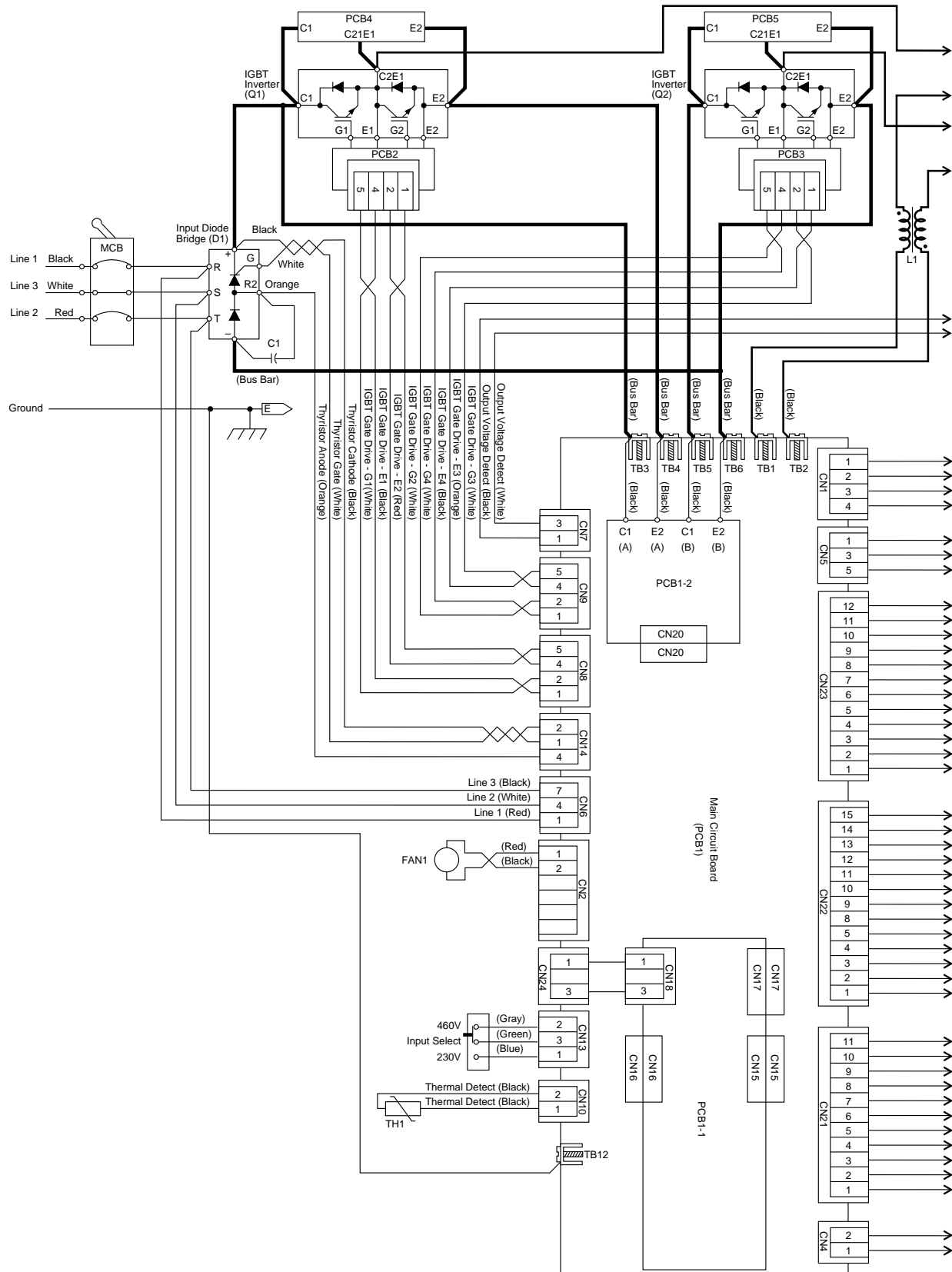



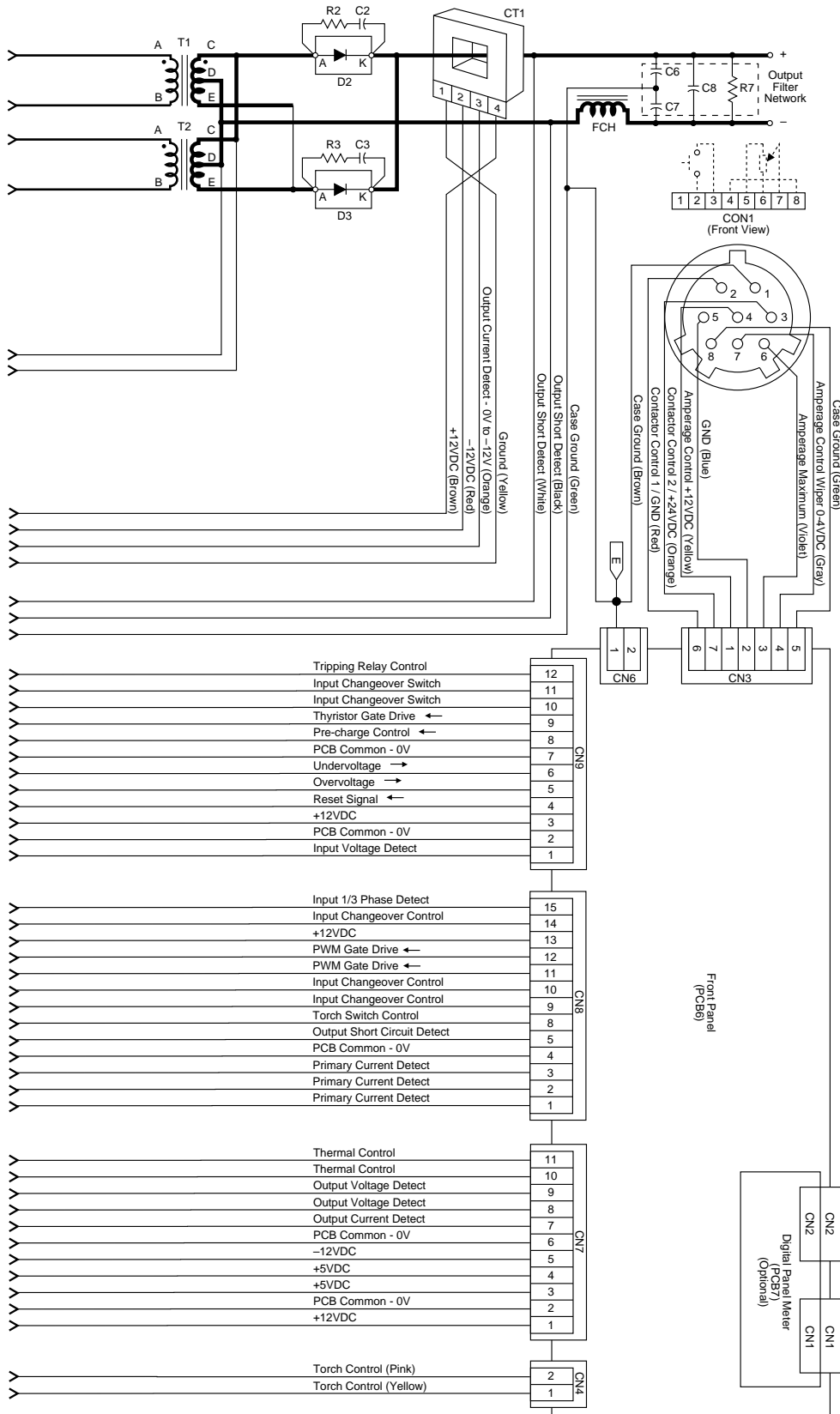

# LS300 - 380-415V Interconnection Diagram

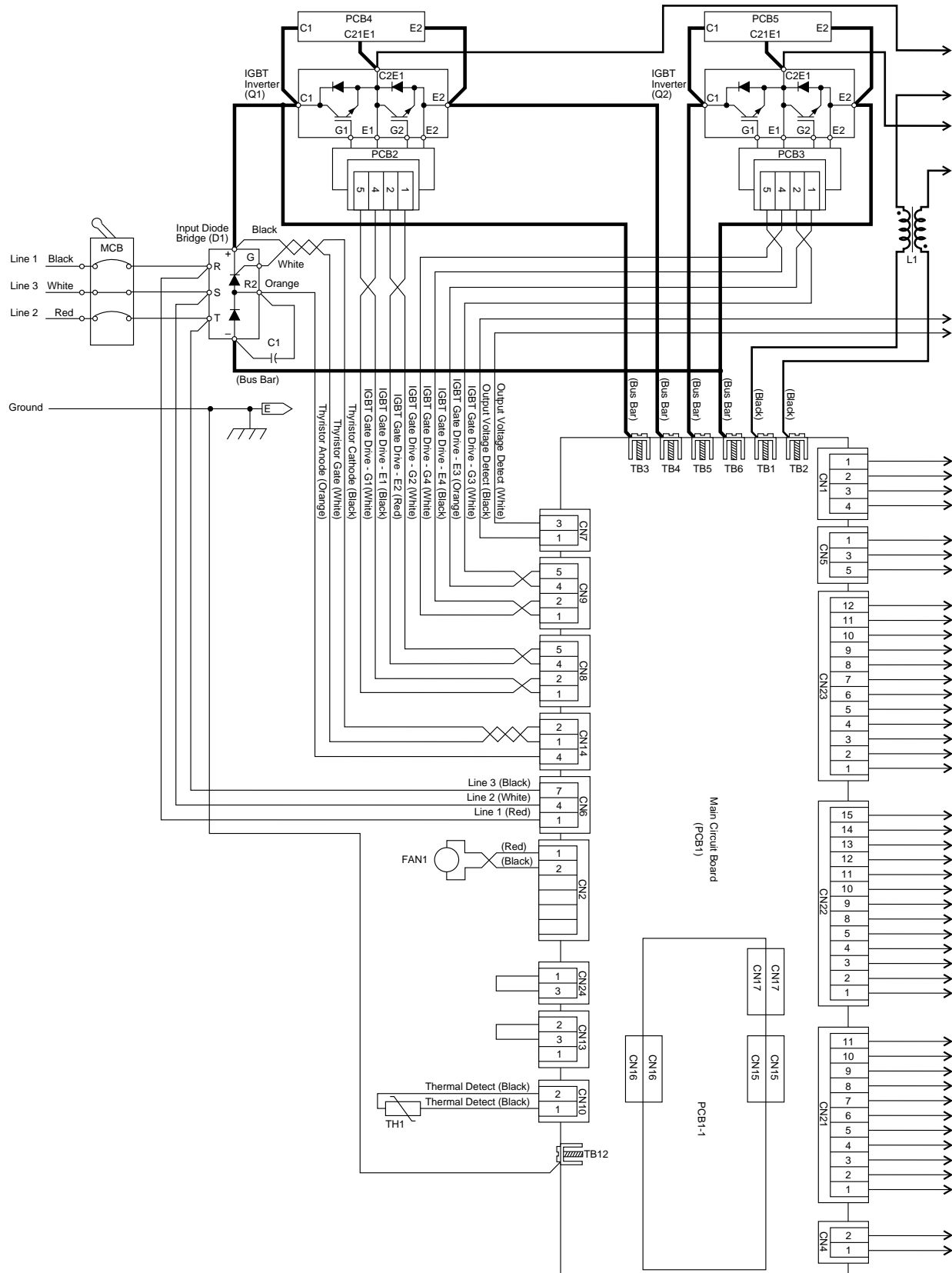

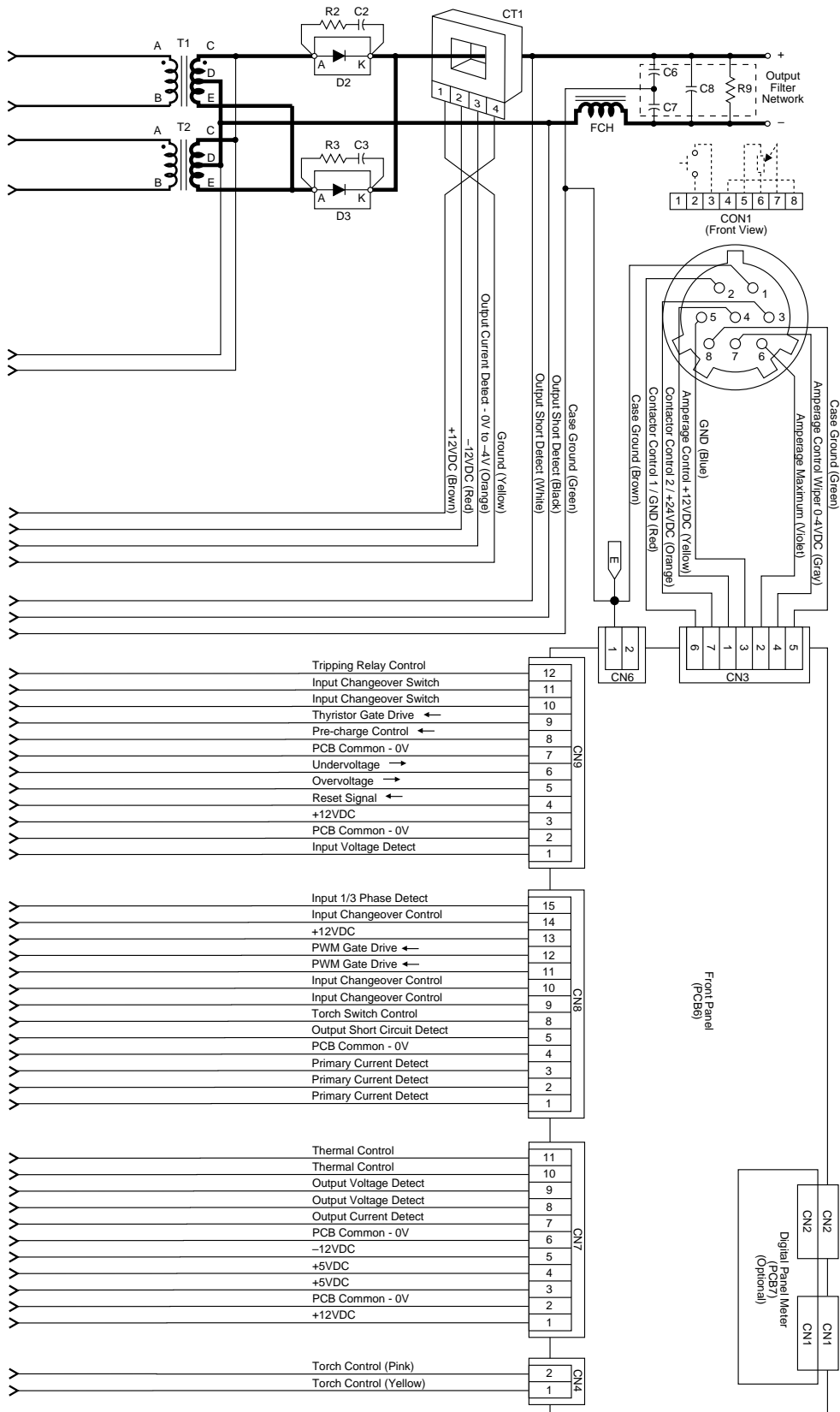

# LS300 - 460/575V Interconnection Diagram

