

SIEMENS

SED2 Variable Frequency Drives

Startup, Operation, and Maintenance Manual



Item Number 125-3201, Rev. 012



SIEMENS

**SED2 Variable
Frequency Drives
Startup, Operation, and
Maintenance Manual**

NOTICE

The information contained within this document is subject to change without notice and should not be construed as a commitment by Siemens Building Technologies, Inc. Siemens Building Technologies, Inc. assumes no responsibility for any errors that may appear in this document.

All software described in this document is furnished under a license and may be used or copied only in accordance with the terms of such license.

SERVICE STATEMENT

Control devices are combined to make a system. Each control device is mechanical in nature and all mechanical components must be regularly serviced to optimize their operation. All Siemens Building Technologies, Inc. branch offices and authorized distributors offer technical support programs that will ensure your continuous, trouble-free system performance.

For further information, contact your nearest Siemens Building Technologies, Inc. representative.

CREDITS

Product or company names mentioned herein may be the trademarks of their respective owners.

Copyright © 2003 by Siemens Building Technologies, Inc.

TO THE READER

Your feedback is important to us. If you have comments about this manual, please submit them to technical.editor@siemens.com.

Printed in U.S.A.

Table of Contents

How To Use This Manual	1
Manual Organization	1
Manual Notations.....	2
Where To Send Comments	2
Reference Documents.....	2
Safety Instructions	3
General	3
Environmental Compatibility and Disposal	4
Mechanical Installation	5
Product Numbers.....	5
Frame Sizes.....	6
Interpreting Serial Numbers and Date Codes	7
Output Ratings.....	8
Accessories	10
Environmental Conditions.....	11
Dimensions and Mounting for IP20 SED2s	12
Overall Dimensions and Mounting Specifications	12
Mounting Dimensions.....	13
Mounting Instructions	13
Gland Plate Installation and Conduit Connections.....	14
Dimensions and Mounting for NEMA Type 1 SED2s	17
Overall Dimensions and Mounting Specifications	17
Mounting Dimensions.....	18
Mounting Instructions	18
Dimensions and Mounting for IP54, NEMA Type 12 SED2s	19
Overall Dimensions and Mounting Specifications	19
Mounting Dimensions.....	20
Mounting Instructions	21
Electrical Installation	22
Extended Storage: Conditioning of Capacitors	23
Input Power and Motor Connections	24
Operation in Ungrounded Systems	25

Ungrounded Systems and Y Capacitor	25
Access to Connection Terminals.....	28
Motor Frequency and Unit of Measurement DIP Switches	31
Input Power and Motor Terminal Layout	32
Tightening Torque for Input Power and Motor Connections	34
Cable Cross-Sections for Input Power and Motor Cables	34
Input Power Connection	37
Motor Cable Length.....	38
Motor Connection (Wye "Y"/Star or Delta Configuration)	39
Direction of Motor Rotation.....	40
Motor Overload Protection	41
Connection of Multiple Motors.....	42
Analog Input DIP Switches.....	43
Control Terminal Connections	44
Control Terminal Layout	44
Analog and Digital I/O Control Terminal Connections	47
Parameters	49
Overview.....	49
Parameter Structure	49
Parameter Indexes	49
SED2 Operator Panels.....	51
Overview.....	51
Basic Operator Panel (BOP)	51
Advanced Operator Panel (AOP)	52
BOP Display and Pushbuttons	52
Commissioning	55
Motor Nameplate Data for Parameter Settings	56
Prerequisites to Startup Procedure	57
SED2 (stand-alone) Startup Procedure.....	59
Quick Commissioning Procedure	61

Additional Parameter Settings	70
Flying Start	70
Automatic Restart	72
Vdc Controller	74
Pulse Frequency	74
Reset to Factory Defaults	75
Network Communications	76
Changing Individual Parameter Digits	77
Maintenance	78
Prerequisites	78
General Inspection and Cleaning	78
Muffin Fan Inspection and Cleaning	78
Re-energize Unit	79
DC Bus Integrity Test	79
Contactors and Switches	79
Motor Bearing Wear	79
Troubleshooting.....	80
Reading Faults	80
Resetting Faults.....	81
Troubleshooting the Operator Panel	82
Troubleshooting Using the Operator Panel	83
Fault Codes	84
Warning Messages	92
Replacement Parts	96
Repair	97
Technical Specifications.....	98
Appendix A: Parameters, Defaults, and Settings	100
Appendix B: SED2 Point Maps	111
Glossary.....	117

How To Use This Manual



This manual is written for users of Siemens Building Technologies, Inc. SED2 Variable Frequency Drives (VFDs). It contains information to install, commission, and set parameters for SED2s in order to provide effective and trouble-free operation.

Manual Organization

This manual contains the following sections:

Section	Description
How to Use this Manual	Describes the organization of this manual, its notations, and lists reference documents.
Safety Instructions	Presents general safety regulations, guidelines, and recommendations.
Mechanical Installation	Provides information for mounting and installing a SED2.
Electrical Installation	Provides information for installing and terminating SED2 wiring.
Parameters	Provides an overview about SED2 parameters.
SED2 Operator Panels	Provides an overview about the SED2 Basic Operator Panel and its pushbuttons
Commissioning	Describes how to commission and start a SED2 for operation.
Maintenance	Provides preventive maintenance information.
Troubleshooting	Lists SED2 fault codes, and warning messages.
Replacement Parts	Provides a list of SED2 replacement parts.
Repairs	Provides repair information.
Appendix A: Parameters, Defaults, and Settings	Provides a table of SED2 parameters with the number, title, and user access level.
Appendix B: SED2 Point Maps	Provides a SED2 P1 point map for APOGEE [®] Automation Systems and a SED2 N2 point map for Johnson Controls, Inc. systems.
Glossary	Defines terms related to the SED2.

Manual Notations

Notation	Symbol	Meaning
DANGER:		Indicates that personal injury, or loss of life may occur if you do not perform a procedure as specified.
WARNING:		Indicates that personal injury, or equipment damage may occur if you do not perform a procedure as specified.
CAUTION:		Indicates that equipment damage, or loss of data may occur if you do not perform a procedure as specified.

Where To Send Comments

Your feedback is important to us. If you have comments about this manual, please submit them to technical.editor@siemens.com.

Reference Documents

SED2s control the speed of fan and pump motors. SED2s can also be programmed to manage many other motor functions and limits set by parameters, which are programmed using the SED2 keypad. See the *SED2 VFD Parameter Reference Guide (125-3214)* for more details and a complete listing of the SED2 parameters.

The following SED2 documentation is available from your local Siemens Building Technologies, Inc. representative:

- *SED2 VFD AOP Operating Instructions (125-3206)*, operating instructions and procedures for the SED2 Advanced Operator Panel.
- *SED2 VFD Conventional Bypass Operating Instructions (125-3215)*, start-up and operation of the SED2 Conventional Bypass Option.
- *SED2 VFD Electronic Bypass Operating Instructions (125-3208)*, start-up, application, and operation of the SED2 Electronic Bypass Option.
- *SED2 VFD LON Interface Option Operating Instructions (125-3212)*, startup and operation of the SED2 LON[®] Interface Option.

Safety Instructions

General

The following general guidelines are provided for your safety, to prevent damage, and to extend the service life of the SED2 product and any connected equipment. *Read this information carefully.* Specific Warnings, Cautions, and Notes are provided in the relevant sections of this manual.



WARNING:

- The SED2 uses hazardous voltages and controls potentially dangerous rotating mechanical parts. Non-compliance with warnings, or failure to follow the instructions contained in this manual, can result in loss of life, severe personal injury, or serious damage to property/equipment.
- Only authorized personnel should work on this equipment, and only after becoming familiar with all local regulations and ordinances, safety notices, and procedures in this manual. Successful and safe operation of this equipment depends upon its proper handling, installation, operation, and maintenance.
- Before doing any installation and commissioning procedures, you must read all safety instructions and warnings, including all warning labels attached to the equipment. Ensure that the warning labels are legible and replace missing or damaged labels.
- Observe the regulations of safety codes whenever working with live equipment and high-voltage installations. Also, use suitable tools and protective equipment.
- Prevent any unauthorized person from accessing or approaching this equipment.

NOTE: Keep this manual near the equipment and available to all users.

Environmental Compatibility and Disposal

The SED2s are developed and manufactured using materials and processes that take full account of environmental issues and which comply with environmental standards. For disposal at the end of the SED2 service life or in the event of its replacement, note the following:

- For disposal purposes, this product is defined as waste derived from electrical and electronic equipment (“electronic waste”) and must not be disposed of as household waste. This applies particularly to the PCB assembly.
- Always use the most environmentally compatible method of disposal, in line with the latest developments in environmental protection, recycling, and waste management. *Observe all local legislation and applicable laws.*
- Always aim for maximum re-use of the basic materials, and minimum environmental stress. Observe any notes about materials and disposal that may be attached to individual components.
- Use local depots and waste management companies, or see your supplier or manufacturer to return used products or to obtain further information on environmental compatibility and waste disposal.
- Special handling of components such as electrolytic capacitors and LCD panels may in some cases be compulsory by law or environmentally desirable.
- The SED2 is delivered in re-usable packaging. Please retain this packaging for later use or in case you need to return the product.

Mechanical Installation

Product Numbers

The following chart shows SED2 product numbers:

Your Product Number:	S	E	D	2	-													
Example Product Number:	S	E	D	2	-	0	.	7	5	/	2	2	X					
Model: SED2-																		
kW: 0.37, 0.55, 0.75, 1.1, 1.5, 2.2, 3, 4, 5.5, 7.5, 11, 15, 18.5, 22, 30, 37, 45, 55, 75, 90	(use 2 to 4 spaces plus a divider "/")																	
Voltage: 2 = 200 to 240 3 = 380 to 480 4 = 500 to 600																		
NEMA: 2 = (IP20) 1 = NEMA Type 1 5 = NEMA Type 12 (IP54) *																		
Other: X = Other																		
	(leave blank)																	

* Available with Voltage Codes 3 and 4.

Example shown:
 SED2-0.75/22X = SED2 only, 0.75 kW (1 hp), 200V to 240V,
 open type IP20.

Frame Sizes

The following chart shows SED2 IP20 and NEMA Type 1 (drive only) frame sizes and power ranges.

HP	.5	.7	1	1.5	2	3	4	5	7.5	10	15	20	25	30	40	50	60	75	100	125
kW	.37	.5	.75	1.1	1.5	2.2	3	4	5.5	7.5	11	15	19	22	30	37	45	55	75	90
240V	A		B			C				D			E		F					
480V	A				B				C			D			E		F			
575V			C							D			E		F					

The following chart shows SED2 IP54, NEMA Type 12 (drive only) frame sizes and power ranges.

HP	.5	.7	1	1.5	2	3	4	5	7.5	10	15	20	25	30	40	50	60	75	100	125
kW	.37	.5	.75	1.1	1.5	2.2	3	4	5.5	7.5	11	15	19	22	30	37	45	55	75	90
480V				B				C					D			E		F		
575V				C							D			E		F				

Interpreting Serial Numbers and Date Codes

Each SED2 has a manufacturing/serial number. The date of manufacture, or the date code, is part of the serial number. The following examples show how to interpret the date code and serial code.

Example 1:

A SED2 manufactured April 21, 2000 with a 000219 serial number.

X	A	M	4	2	1	-	0	0	0	2	1	9
Indicates manufacturing location		Year: M = 00 N = 01 O = 02 P = 03 Q = 04	Month: Jan = 1, Feb = 2, . . . Sept = 9, Oct = O, Nov = N, Dec = D	Day: 01 through 31	A separator to facilitate reading of the serial number.		Six-digit serial number in the range of 1 through 999999.					

Example 2:

A SED2 manufactured July 24, 2001 with a 00535 serial number.

T	-	N	7	2	4	6	2	0	0	0	5	3	5
Indicates manufacturing location		Year: M = 00 N = 01 O = 02 P = 03 Q = 04	Month: Jan = 1, Feb = 2, . . . Sept = 9, Oct = O, Nov = N, Dec = D	Day: 01 through 31	Product number		Five-digit serial number in the range of 1 through 99999.						

Output Ratings

Table 1 shows SED2 product numbers and the associated output ratings.

Table 1. SED2 Product Numbers and Output Ratings.

Voltage (±10%)	Product Number			Output Rating		Output Current Max. (amps)	Frame Size
	IP20	NEMA Type 1	IP54, NEMA Type 12	HP	kW		
208V to 240V (3-Phase)	SED2-0.37/22X	SED2-0.37/21X	—	0.5	0.37	2.3	A
	SED2-0.55/22X	SED2-0.55/21X	—	0.75	0.55	3.0	A
	SED2-0.75/22X	SED2-0.75/21X	—	1.0	0.75	3.9	A
	SED2-1.1/22X	SED2-1.1/21X	—	1.5	1.1	5.5	B
	SED2-1.5/22X	SED2-1.5/21X	—	2.0	1.5	7.4	B
	SED2-2.2/22X	SED2-2/21X	—	3.0	2.2	10.4	B
	SED2-3/22X	SED2-3/21X	—	4.0	3.0	13.6	C
	SED2-4/22X	SED2-4/21X	—	5.0	4.0	17.5	C
	SED2-5.5/22X	SED2-5.5/21X	—	7.5	5.5	22.0	C
	SED2-7.5/22X	SED2-7.5/21X	—	10.0	7.5	28.0	C
	SED2-11/22X	SED2-11/21X	—	15.0	11.0	42.0	D
	SED2-15/22X	SED2-15/21X	—	20.0	15.0	54.0	D
	SED2-18.5/22X	SED2-18.5/21X	—	25.0	18.5	68.0	D
	SED2-22/22X	SED2-22/21X	—	30.0	22.0	80.0	E
	SED2-30/22X	SED2-30/21X	—	40.0	30.0	104.0	E
	SED2-37/22X	SED2-37/21X	—	50.0	37.0	130.0	F
	SED2-45/22X	SED2-45/21X	—	60.0	45.0	154.0	F
380V to 480V (3-Phase)	SED2-0.37/32X	SED2-0.37/31X	—	0.5	0.37	2.1	A
	SED2-0.55/32X	SED2-0.55/31X	—	0.75	0.55	2.6	A
	SED2-0.75/32X	SED2-0.75/31X	—	1.0	0.75	2.1	A
	SED2-1.1/32X	SED2-1.1/31X	SED2-1.1/35X	1.5	1.1	3.0	A *
	SED2-1.5/32X	SED2-5/31X	SED2-1.5/35X	2.0	1.5	4.0	A *
	SED2-2.2/32X	SED2.2/31X	SED2-2/35X	3.0	2.2	5.9	B
	SED2-3/32X	SED2-3/31X	SED2-3/35X	4.0	3.0	7.7	B
	SED2-4/32X	SED2-4/31X	SED2-4/35X	5.0	4.0	10.2	B
	SED2-5.5/32X	SED2-5.5/31X	SED2-5.5/35X	7.5	5.5	13.2	C
	SED2-7.5/32X	SED2-7.5/31X	SED2-7/5/35X	10.0	7.5	18.4	C
	SED2-11/32X	SED2-11/31X	SED2-11/35X	15.0	11.0	26.0	C
	SED2-15/32X	SED2-15/31X	SED2-15/35X	20.0	15.0	32.0	C
	SED2-18.5/32X	SED2-18.5/31X	SED2-18.5/35X	25.0	18.5	38.0	D
	SED2-22/32X	SED2-22/31X	SED2-22/35X	30.0	22.0	45.0	D
	SED2-30/32X	SED2-30/31X	SED2-30/35X	40.0	30.0	62.0	D
	SED2-37/32X	SED2-37/31X	SED2-37/35X	50.0	37.0	75.0	E
	SED2-45/32X	SED2-45/31X	SED2-45/35X	60.0	45.0	90.0	E
SED2-55/32X	SED2-55/31X	SED2-55/35X	75.0	55.0	110.0	F	
SED2-75/32X	SED2-75/31X	SED2-75/35X	100.0	75.0	145.0	F	
SED2-90/32X	SED2-90/31X	SED2-90/35X	125.0	90.0	178.0	F	

* IP54, NEMA Type 12 drives start at Frame Size B.

Table 1. SED2 Product Numbers and Output Ratings. (Continued)

Voltage (±10%)	Product Number			Output Rating		Output Current Max. (amps)	Frame Size
	IP20	NEMA Type 1	IP54, NEMA Type 12	HP	kW		
500V to 600V (3-Phase)	SED2-0.75/42X	SED2-0.75/41X	—	1.0	0.75	1.4	C
	SED2-1.1/42X	SED2-1.1/41X	SED2-1.1/45X	1.5	1.1	2.1	C
	SED2-1.5/42X	SED2-1.5/41X	SED2-1.5/45X	2.0	1.5	2.7	C
	SED2-2.2/42X	SED2-2.2/41X	SED2-2.2/45X	3.0	2.2	3.9	C
	SED2-3/42X	SED2-3/41X	SED2-3/45X	4.0	3.0	5.4	C
	SED2-4/42X	SED2-4/41X	SED2-4/45X	5.0	4.0	6.1	C
	SED2-5.5/42X	SED2-5.5/41X	SED2-5.5/45X	7.5	5.5	9.0	C
	SED2-7.5/42X	SED2-7.5/41X	SED2-7.5/45X	10.0	7.5	11.0	C
	SED2-11/42X	SED2-11/41X	SED2-11/45X	15.0	11.0	17.0	C
	SED2-15/42X	SED2-15/41X	SED2-15/45X	20.0	15.0	22.0	C
	SED2-18.5/42X	SED2-18.5/41X	SED2-18.5/45X	25.0	18.5	27.0	D
	SED2-22/42X	SED2-22/41X	SED2-22/45X	30.0	22.0	32.0	D
	SED2-30/42X	SED2-30/41X	SED2-30/45X	40.0	30.0	41.0	D
	SED2-37/42X	SED2-37/41X	SED2-37/45X	50.0	37.0	52.0	E
	SED2-45/42X	SED2-45/41X	SED2-45/45X	60.0	45.0	62.0	E
	SED2-55/42X	SED2-55/41X	SED2-55/45X	75.0	55.0	77.0	F
	SED2-75/42X	SED2-75/41X	SED2-75/45X	100.0	75.0	99.0	F
SED2-90/42X	SED2-90/41X	SED2-90/45X	125.0	90.0	125.0	F	

Accessories

SED 2 accessories include the following:

Gland Plates

- SED2-GL-A, Gland Plate, Frame A (included with NEMA Type 1)
- SED2-GL-B, Gland Plate, Frame B (included with NEMA Type 1)
- SED2-GL-C, Gland Plate, Frame C (included with NEMA Type 1)

BOP/AOP Door Mounting Kits

- SED2-Door-Kit1, BOP/AOP Single Inverter Door Mounting Kit
- SED2-Door-Kit2, AOP Multi-Inverter Door Mounting Kit

Protection Shields (included with NEMA Type 1)

- SED2-PS-A, Protection Shield, Frame A
- SED2-PS-B, Protection Shield, Frame B
- SED2-PS-C, Protection Shield, Frame C
- SED2-PS-DE, Protection Shield, Frame D, E

Operator Panel

- SED2-BOP1, Basic Operator Panel (included with all SED2s)
- SED2-AOP1, Advanced Operator Panel

LON Interface Option

- SED2-LONI/F

Modbus Interface Cable

- SED2-MODBUS1, Converts SED2 USS bus to Modbus RTU

Environmental Conditions

Install the SED2 in a heated, indoor-controlled environment that is free of moisture and conductive contaminants, such as condensation and dust. The air entering the unit for ventilation or cooling must be clean and free of corrosive materials. If installed in a confined space, remove the heat from the area by ventilation or by air conditioning equipment. The ambient temperature must be between 14°F and 104°F (–10°C and 40°C) and the relative humidity must be 0% to 95% non-condensing. Do not mount unit in direct sunlight.

Storage Temperature:

Maximum temperature: +158°F (+70°C) *

Minimum temperature: –40°F (–40°C)

Operating Temperature:

Maximum temperature: +104°F (+40°C) *

Minimum temperature: +14°F (–10°C)

* Be aware of the potential increase in temperature inside a control cabinet (de-rating is required; contact the factory).

Humidity: Maximum 95% rh (non-condensing)

Altitude: The SED2 can be installed at altitudes up to 3280 ft (1000 m) above sea level with no reduction in output current rating (contact the factory).

NOTE: If installing the SED2 at an altitude higher than 3280 ft (1000 m) above sea level, de-rating is required.

Location: Do not install the SED2 in an area that is exposed to repeated shock or vibration, water hazards, or atmospheric pollutants such as dust and corrosive gases.

EMI and RFI: Do not install the SED2 near powerful sources of electromagnetic interference (EMI) and radio frequency interference (RFI) without a suitable filter.

Dimensions and Mounting for IP20 SED2s

Overall Dimensions and Mounting Specifications

Table 2. Overall Dimensions of IP20 SED2 in Inches (Millimeters).

Frame Size	Height	Width	Depth	Mounting Specification	Tightening Torque lb-in (Nm)	Weight lb (kg)
A	6.8 (173)	2.9 (73)	5.9 (149)	2 x M4 Bolts, Nuts, and Washers, or Connecting to DIN rail	22 (2.5)	2.9 (1.3)
B	8.0 (202)	5.9 (149)	6.8 (172)	4 x M4 Bolts, Nuts, and Washers	22 (2.5)	7.5 (3.4)
C	9.6 (245)	7.3 (185)	7.7 (195)	4 x M5 Bolts, Nuts, and Washers	26 (3.0)	12.1 (5.5)
D	20.5 (520)	10.8 (275)	9.6 (245)	4 x M8 Bolts, Nuts, and Washers	115 (13)	35.3 (16)
E	25.6 (650)	10.8 (275)	9.6 (245)	4 x M8 Bolts, Nuts, and Washers	115 (13)	44.1 (20)
F	33.5 (850)	13.8 (350)	12.6 (320)	4 x M8 Bolts, Nuts, and Washers	221 (25)	116 (53)

Mounting Dimensions

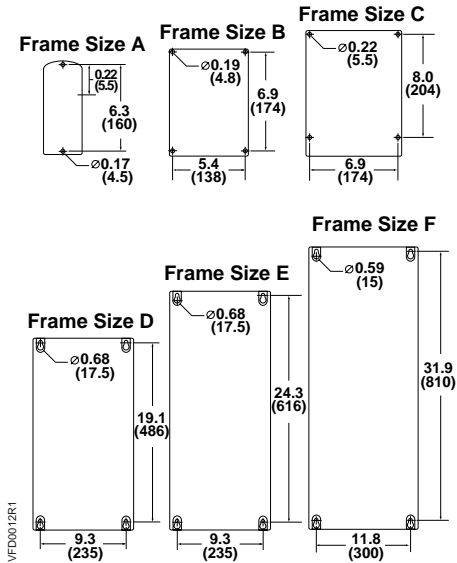
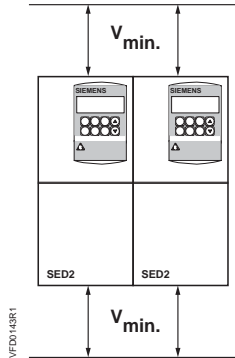

Figure 1. Mounting Dimensions of IP20 SED2 in Inches (Millimeters).

Mounting Instructions

The IP20 SED2 can mount side-by-side without space in between units. There must be a minimum clearance at the top and bottom for ventilation and equipment access.



Frame Size	V _{min} Minimum Clearance in Inches (Millimeters)
A, B, C	4 (100)
D, E	11-3/4 (300)
F	13-3/4 (350)

Mounting Clearance Note:

If fitted with a protective shield, allow 12-inches (305 mm) of space between each SED2 to allow for sufficient heat dissipation.

Gland Plate Installation and Conduit Connections



CAUTION:

Bonding between conduit connections is not automatic and must be provided as part of the installation.

Each bonding conductor must be equal or greater in cross-section to the power supply cable.

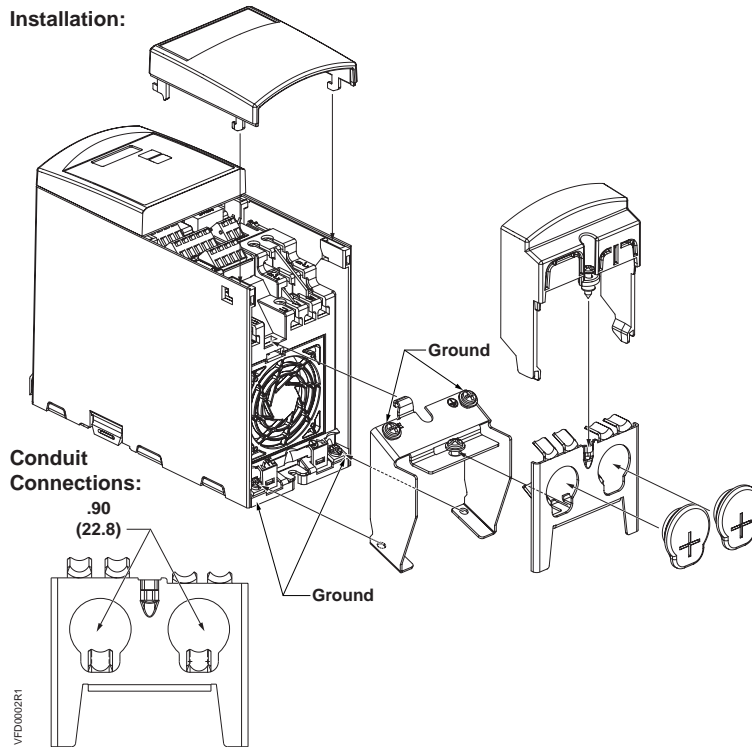

Figure 2. Gland Plate Installation and Conduit Connection Diameters for Frame Size A.

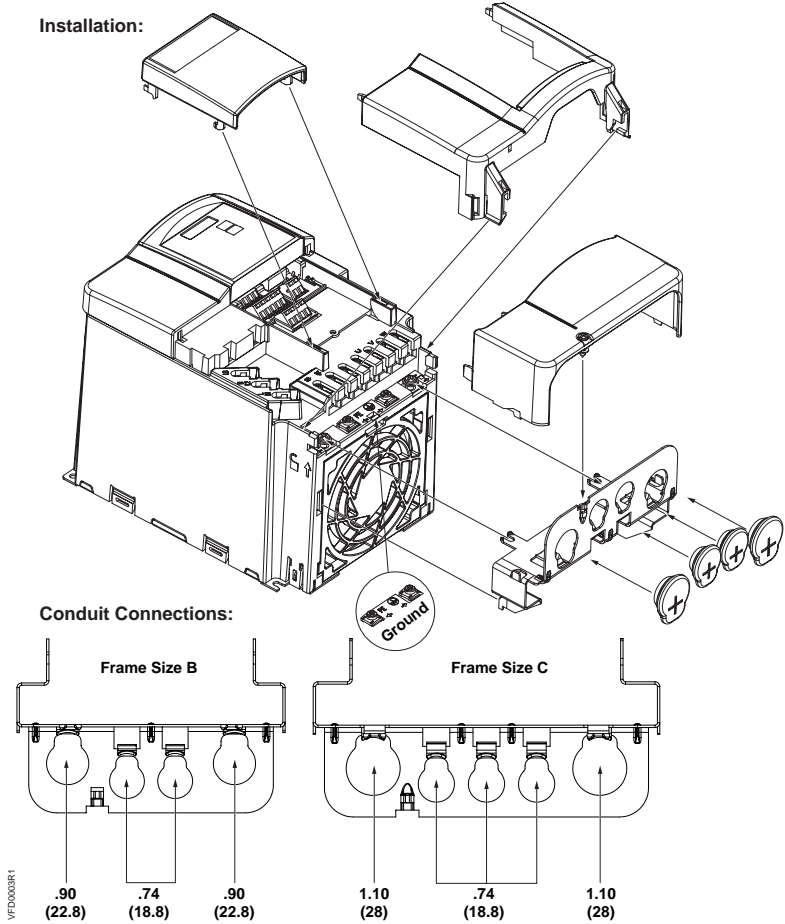

Figure 3. Gland Plate Installation and Conduit Connection Diameters for Frame Size B and C.

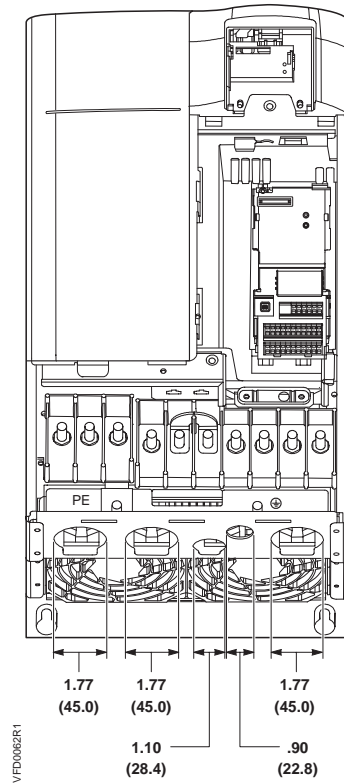

Figure 4. Conduit Connection Diameters for Frame Size D and E in Inches (Millimeters).

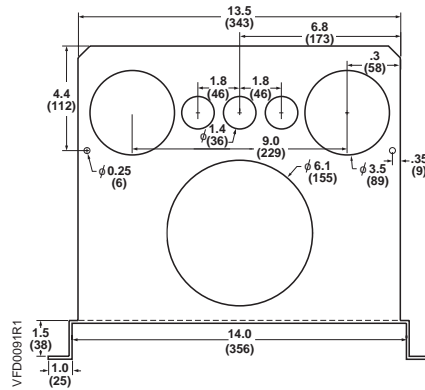

Figure 5. Conduit Connection Diameters (Bottom View) for Frame Size F in Inches (Millimeters).

Dimensions and Mounting for NEMA Type 1 SED2s

Overall Dimensions and Mounting Specifications

Table 3. Overall Dimensions of NEMA Type 1 SED2 Assembled with a Protective Shield and a Gland Plate. Dimensions in Inches (Millimeters).

Frame Size	Height	Width	Depth	Mounting Specification	Tightening Torque lb-in (Nm)	Weight lb (kg)
A	9.1 (231)	2.9 (73)	5.9 (149)	2 x M4 Bolts, Nuts, and Washers, or Connecting to DIN rail	22 (2.5)	3.2 (1.5)
B	11.8 (300)	5.9 (149)	6.8 (172)	4 x M4 Bolts, Nuts, and Washers	22 (2.5)	8.3 (3.8)
C	13.8 (351)	7.3 (185)	7.7 (195)	4 x M5 Bolts, Nuts, and Washers	26 (3.0)	13.6 (6.2)
D	24.6 (625)	10.8 (275)	9.6 (245)	4 x M8 Bolts, Nuts, and Washers	115 (13)	37.5 (17.1)
E	29.7 (754)	10.8 (275)	9.6 (245)	4 x M8 Bolts, Nuts, and Washers	115 (13)	46.4 (21.1)
F	54.5 (1384)	16.0 (406)	14.0 (356)	4 x M8 Bolts, Nuts, and Washers	221 (25)	200 (91)

Mounting Dimensions

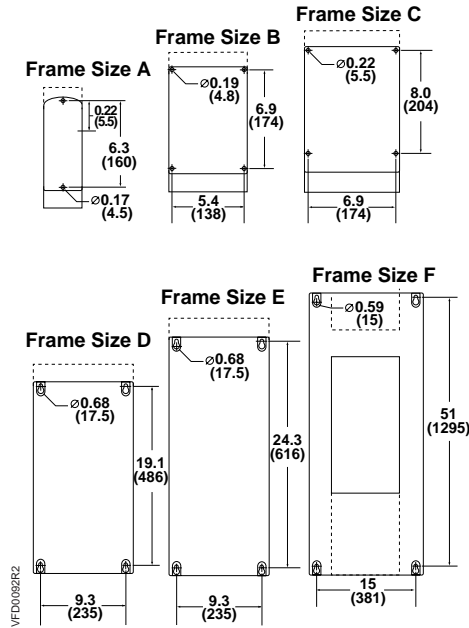
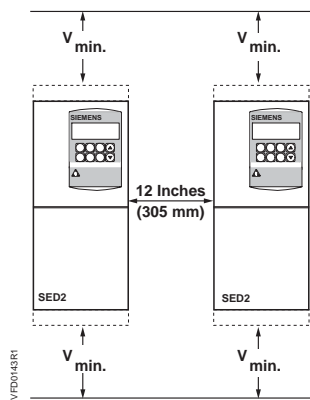

Figure 6. Mounting Dimensions of NEMA Type 1 SED2 in Inches (Millimeters).

Mounting Instructions

The NEMA Type 1 SED2 must have a minimum clearance at the top and bottom for ventilation and equipment access. In addition, allow 12-inches (305 mm) of space between each SED2 to allow for sufficient heat dissipation.



Frame Size	V _{min} Minimum Clearance in Inches (Millimeters)
A, B, C	4 (100)
D, E	11-3/4 (300)
F	13-3/4 (350)

Dimensions and Mounting for IP54, NEMA Type 12 SED2s

Overall Dimensions and Mounting Specifications

Table 4. Overall Dimensions and Mounting Clearances for IP54, NEMA Type 12 SED2. Dimensions in Inches (Millimeters).

Frame Size	Overall Dimensions			Mounting Clearance			Mounting Specification	Tightening Torque lb-in (Nm)	Weight lb (kg)
	Height	Width	Depth	Top	Bottom	Sides			
B	15.2 (385)	10.6 (270)	10.6 (268)	5.9 (150)	5.9 (150)	3.9 (100)	4 x M6 Bolts, Nuts, and Washers	44 (5)	22 (10)
C	23.9 (606)	13.8 (350)	11.2 (284)	5.9 (150)	5.9 (150)	3.9 (100)	4 x M6 Bolts, Nuts, and Washers	44 (5)	42 (19)
D	27.0 (685)	14.2 (360)	13.9 (353)	7.9 (200)	7.9 (200)	5.9 (150)	4 x M8 Bolts, Nuts, and Washers	115 (13)	77 (35)
E	34.8 (885)	14.2 (360)	17.8 (453)	7.9 (200)	7.9 (200)	5.9 (150)	4 x M8 Bolts, Nuts, and Washers	115 (13)	105 (48)
F	45.3 (1150)	17.7 (450)	18.6 (473)	11.8 (300)	9.8 (250)	5.9 (150)	4 x M8 Bolts, Nuts, and Washers	177 (20)	178 (81)

Mounting Dimensions

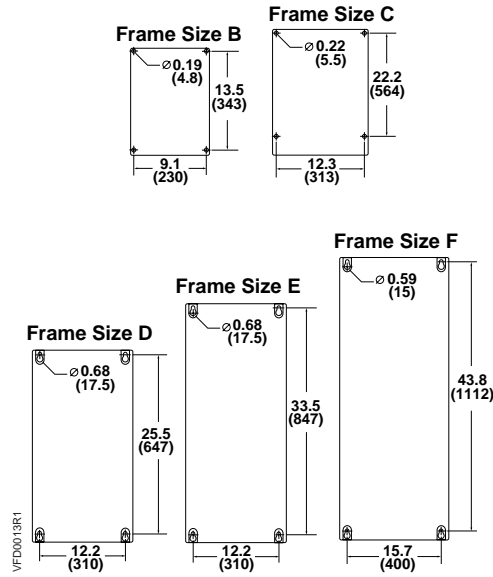
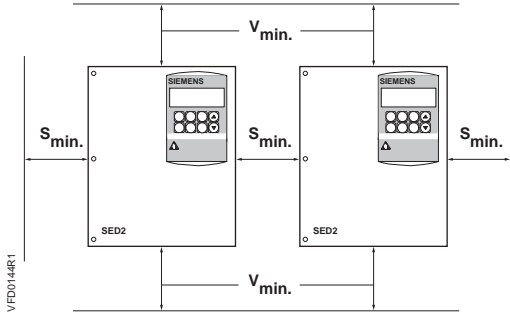

Figure 7. Mounting Dimensions of IP54, NEMA Type 12 SED2 in Inches (Millimeters).

Mounting Instructions

There must be a clearance of at least 5-7/8 inches (150 mm) in all directions. A good bonding between the SED2 and the metal backplate is necessary to ensure good grounding and low RFI (radio frequency interference). If necessary, remove some backplate paint and/or use toothed washers to ensure safety and EMC (electro-magnetic compatibility). Earth braided screened armored cable provides the best bond.



Frame Size	S_{min} Minimum Clearance in Inches (Millimeters)	V_{min} Minimum Clearance in Inches (Millimeters)
B, C	5-7/8 (150)	5-7/8 (150)
D, E	5-7/8 (150)	11-3/4 (300)
F	5-7/8 (150)	13-3/4 (350)

NOTE: Install the SED2 vertically for optimum cooling. Do not obstruct the vents on the SED2. Additional ventilation may be required if the SED2 is mounted horizontally.

Electrical Installation



DANGER:

- To ensure safe operation of the SED2, authorized persons must install and commission it in full compliance with the warnings, cautions, and notes in this manual. Authorized persons must also follow general and regional installation and safety regulations regarding working with high voltages as well as relevant regulations for the correct use of tools and protective equipment.
- **The SED2 must be grounded** (per IEC 536, Class 1, NEC and other relevant industry standards). Extremely hazardous conditions may result if the SED2 is not correctly grounded.

NOTE: IP20 and NEMA Type 1 SED2s can operate in ungrounded systems if the Y capacitor is disconnected or removed.
IP54, NEMA Type 12 SED2s cannot operate in ungrounded systems. See the *Operation in Ungrounded Systems* section for more details.

- The SED2 is suitable for use in a circuit capable of delivering **not more than 10,000** symmetrical amperes, for a maximum voltage of 240/480/575V when protected by a time delay Type J, H, or K fuse or circuit breaker.
- **Always wait 5 minutes** after disconnecting the SED2 from the power source before performing any work. The DC link capacitors of all SED2s remain charged with dangerous voltages for 5 minutes after all power sources have been disconnected. When working on IP20 units, note that live parts are exposed. Do not touch these parts.
- In cases where a fault in the input or output power wiring could cause significant equipment damage or severe physical injury (such as potentially dangerous short circuits), use additional external precautions to ensure safe operation (such as independent limit switches and mechanical interlocks).

Extended Storage: Conditioning of Capacitors

After an extended period of storage, recharge the capacitors in the SED2. Calculate the storage time from the *date of manufacture* or the *date code*, and not from the date of delivery. (See the *Interpretation of Serial Numbers and Date Codes* section for more details.) The recharge procedure varies according to the storage period as follows:

Period of Storage	Required Action	Total Preparation Time
1 year or less	Recharging not required.	No preparation
1 to 2 years	Before issuing the “run” command, connect the SED2 to input power for one hour.	1 hour
2 to 3 years	Use a variable AC power source as follows: <ul style="list-style-type: none"> • Apply 25% of the input voltage for 30 minutes. • Increase the voltage to 50% for an additional 30 minutes. • Increase the voltage to 75% for an additional 30 minutes. • Increase the voltage to 100% for an additional 30 minutes. The SED2 is then ready for operation.	2 hours
3 or more years	Use a variable AC power source as follows: <ul style="list-style-type: none"> • Apply 25% of the input voltage for 2 hours. • Increase the voltage to 50% for an additional 2 hours. • Increase the voltage to 75% for an additional 2 hours. • Increase the voltage to 100% for an additional 2 hours. The SED2 is then ready for operation.	8 hours



CAUTION:

After an extended period of storage, if capacitors are not properly recharged, catastrophic damage to the drive can result.

Input Power and Motor Connections



DANGER:

- Make certain that the motor rated full load amps (FLA) does NOT exceed the rated output current of the SED2 controlling it.

When multiple motors are simultaneously operated by the SED2, the sum of all motor rated FLA values must be less than or equal to the SED2 controlling them.

- Never switch on the SED2 with it open.
- Always isolate the input power cables before connecting them to the SED2.
- Always use insulated tools when working on input power and motor terminals.
- Ensure that terminal covers are securely replaced after connecting the input power and motor cables.



WARNING:

- Verify that the SED2 and motor are correctly rated for the input power voltage.
- Verify that the input power cables are correctly sized for the anticipated use.
- Confirm that appropriate circuit breakers or fuses have been installed between the input power supply and the SED2.
- Never use high-voltage insulation test equipment on any cables connected to the SED2.

Operation in Ungrounded Systems

IP20 and NEMA Type 1 SED2s can operate in ungrounded systems if the Y capacitor is disconnected or removed. They remain in operation when an input ground fault occurs. In the event of an output ground fault, the SED2 switches off and displays fault code F001.

NOTE: IP54, NEMA Type 12 SED2s cannot operate in ungrounded systems.

Ungrounded Systems and Y Capacitor

In ungrounded systems, remove or disconnect the Y capacitor (and install an output choke/load reactor) per Figures 8 through 11.

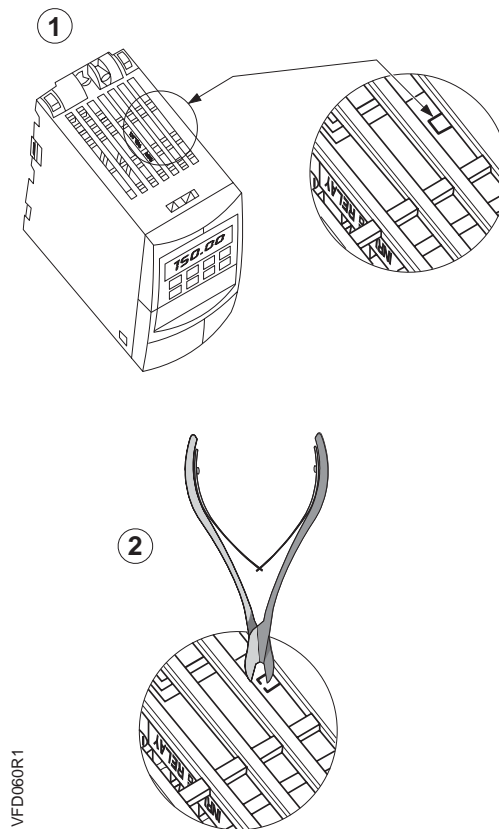

Figure 8. Disconnecting Y Capacitor in SED2 Frame Size A.

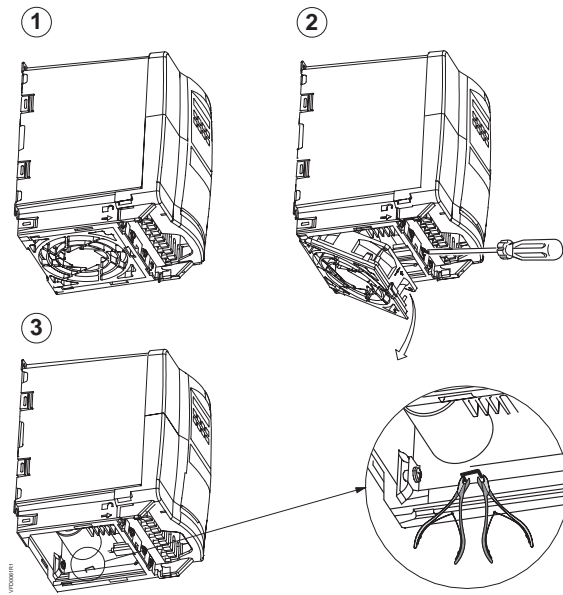

Figure 9. Disconnecting Y Capacitor in SED2 Frame Size B and C.

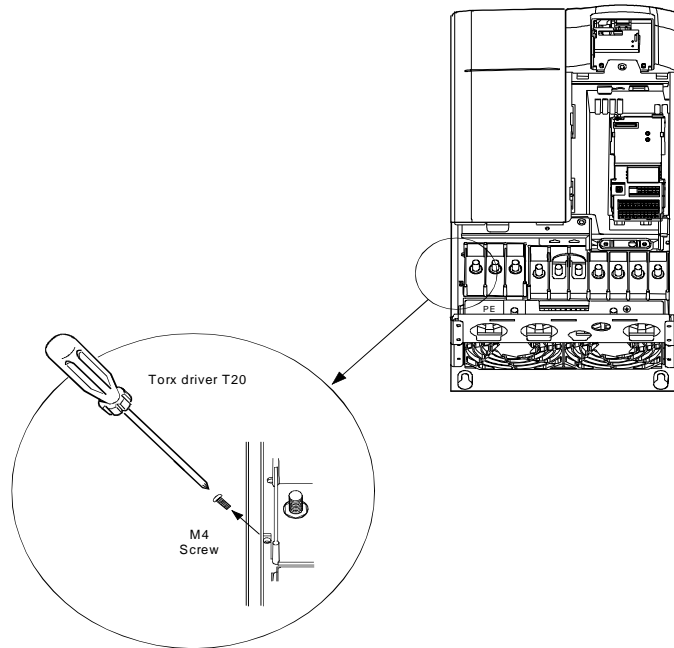

Figure 10. Disconnecting Y Capacitor in SED2 Frame Size D and E.

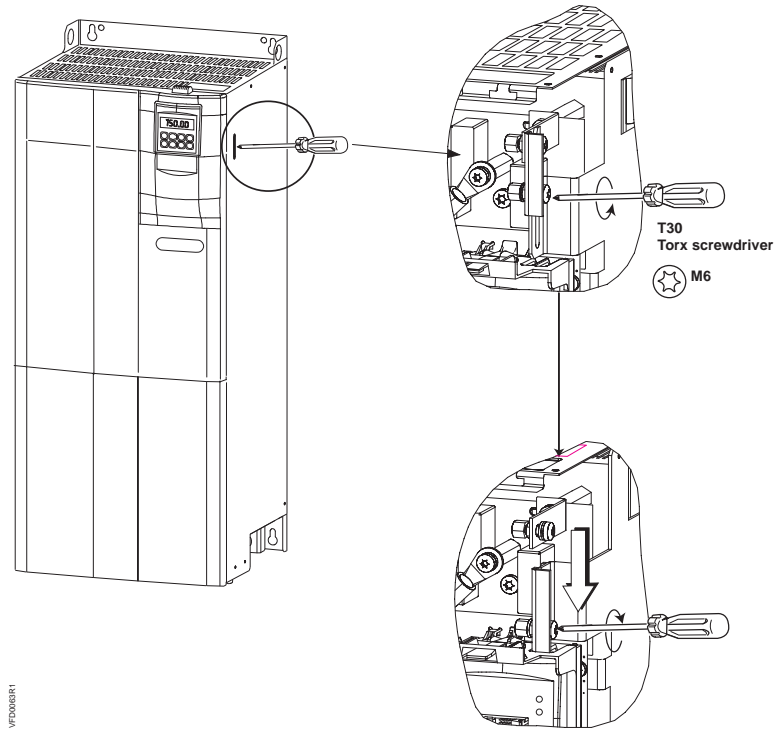

Figure 11. Disconnecting Y Capacitor in SED2 Frame Size F.

Access to Connection Terminals

To access input power and output motor connection terminals, remove the cover, operator panel, terminal cover, and I/O module per Figures 12 through 17.

The I/O module is located under the operator panel. In frame sizes A through C/IP20, and NEMA Type 1 SED2s, the operator panel directly connects to the I/O module. In frame sizes D through F, and all IP54 NEMA Type 12 SED2s, the operator panel connects to the I/O module via a cable.

In all SED2s, the control module is located under the I/O module.

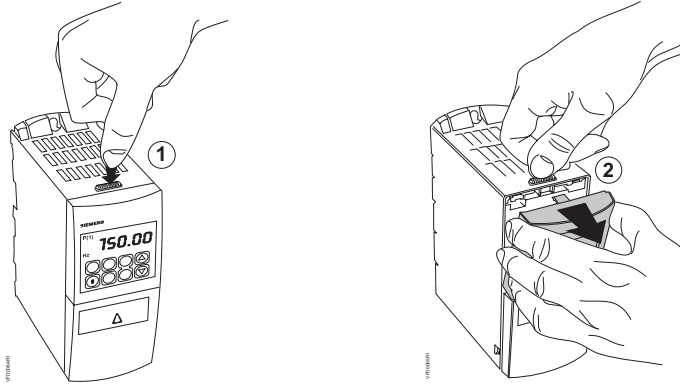

Figure 12. Removing Operator Panel (All Frame Sizes).

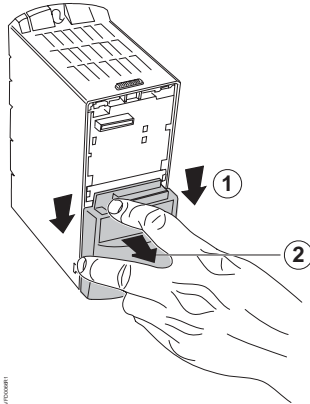

Figure 13. Removing Terminal Cover (All Frame Sizes).

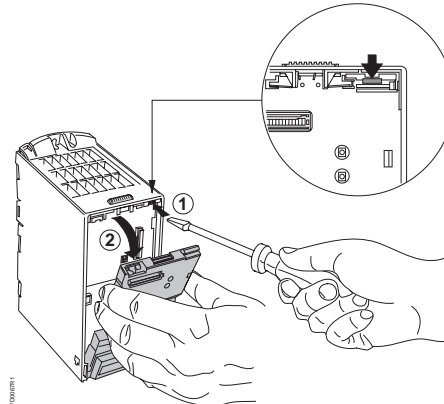

Figure 14. Removing I/O Module (All Frame Sizes).

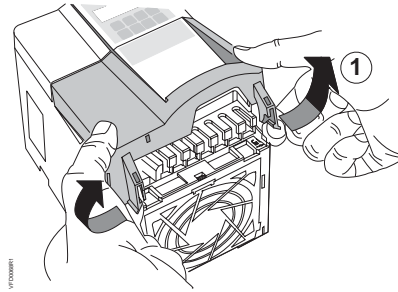

Figure 15. Removing Cover on Frame Sizes B and C.

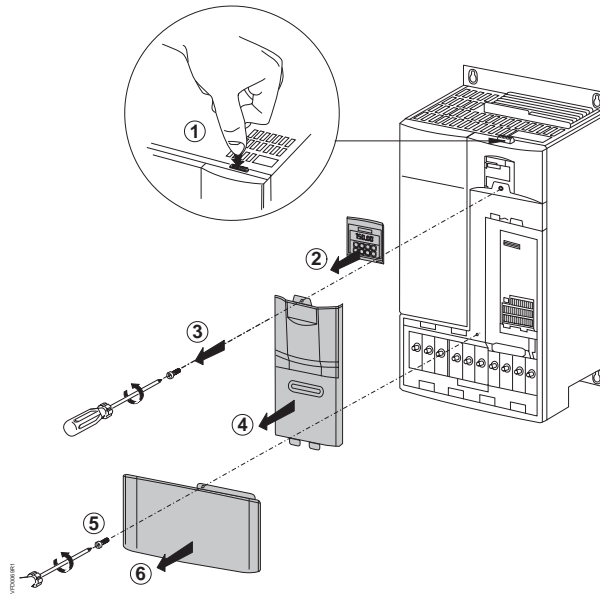

Figure 16. Accessing Connection Terminals for Frame Sizes D and E.

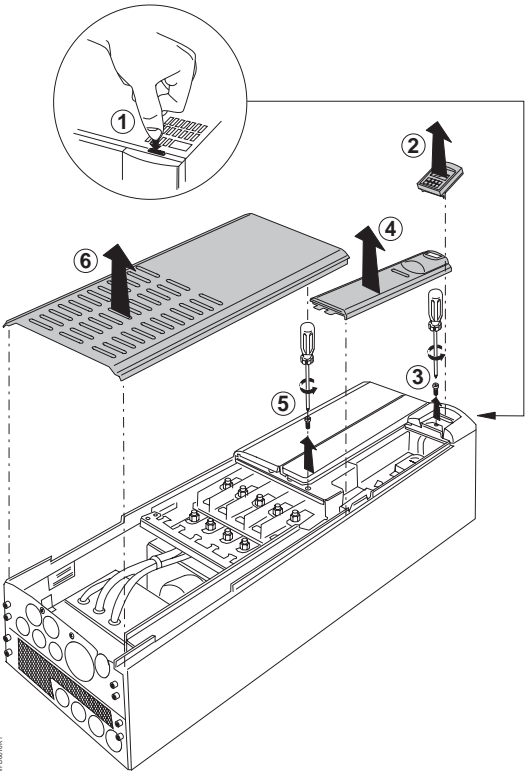

Figure 17. Accessing Connection Terminals for Frame Size F.

Motor Frequency and Unit of Measurement DIP Switches

In all versions of the SED2, DIP switches for selecting motor frequency and unit of measurement are located on the control module under the I/O module. (See *Access to Connection Terminals* section for disassembly instructions.)

DIP Switch	Position	Function
2 *	ON	North American operation (60 Hz, hp).
	OFF	European operation (50 Hz, kW), factory default .
1	OFF	Not for customer use. NOTE: This switch must be OFF for correct operation.

* Set DIP switch 2 ON (60 Hz, hp) for all North American installations.

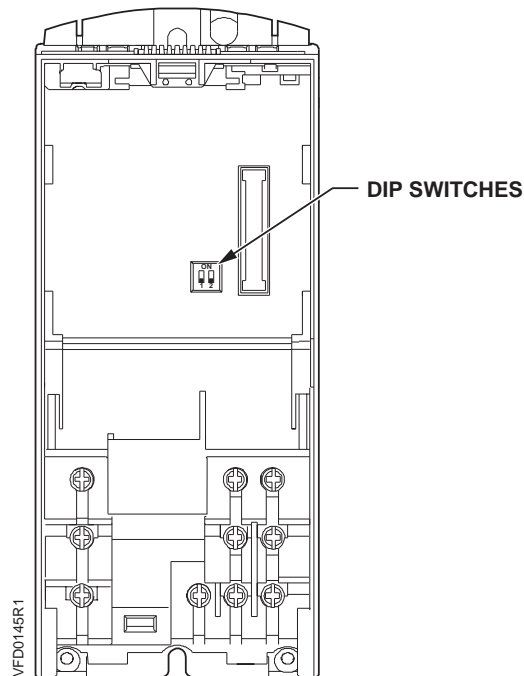

Figure 18. Location of Motor Frequency and Unit of Measurement DIP Switches on Control Module.

Input Power and Motor Terminal Layout



DANGER:

The following terminals carry hazardous voltages even when the SED2 is not running:

- Input power terminals: L1, L2, L3
- Motor terminals: U, V, W
- Link terminals: DC-, DC+/B+, DC/R+, B- (not for customer use)

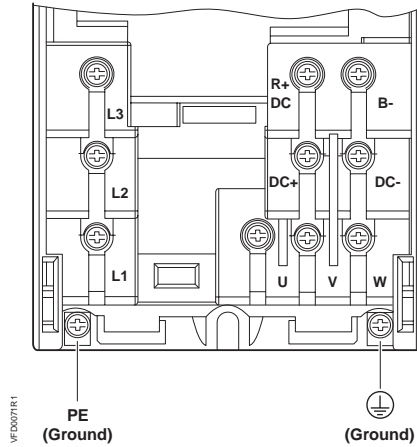

Figure 19. Input Power and Motor Terminal Layout for SED2 Frame Size A.

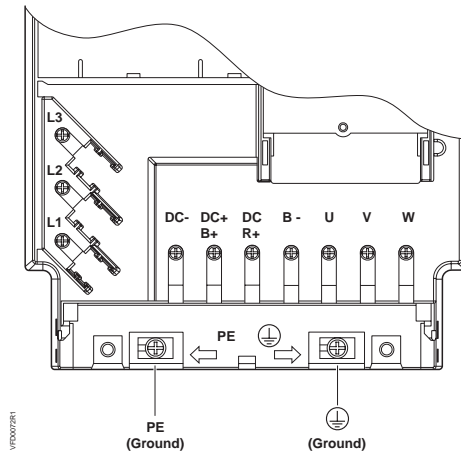

Figure 20. Input Power and Motor Terminal Layout for SED2 Frame Size B and C.

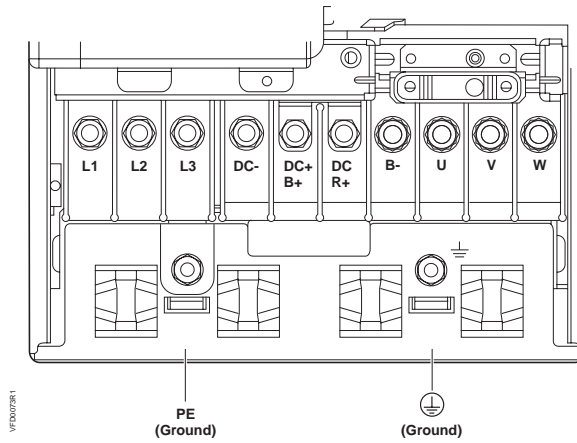

Figure 21. Input Power and Motor Terminal Layout for SED2 Frame Size D and E.

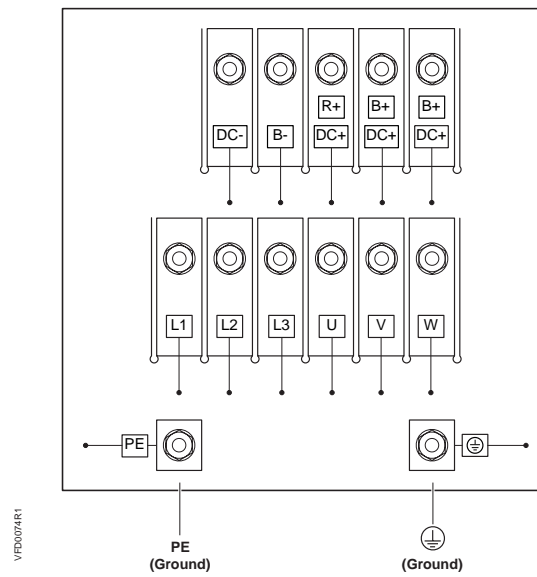

Figure 22. Input Power and Motor Terminal Layout for SED2 Frame Size F.

Tightening Torque for Input Power and Motor Connections

Frame size	A	B	C	D	E	F
Tightening torque lb-in (Nm)	9.7 (1.1)	13.3 (1.5)	19.9 (2.25)	88.5 (10) max.	88.5 (10) max.	442 (50)

Cable Cross-Sections for Input Power and Motor Cables

Table 5. Cable Cross-Sections for Input Voltage Range
3Ø AC 200V through 240V.

Maximum Output rating kW (hp)	Input Power Cable		Motor Cable	
	Minimum Cross-Section AWG (mm ²)	Maximum Cross-Section AWG (mm ²)	Minimum Cross-Section AWG (mm ²)	Maximum Cross-Section AWG (mm ²)
0.37 (.50)	17 (1)	13 (2.5)	17 (1)	13 (2.5)
0.55 (.75)	17 (1)	13 (2.5)	17 (1)	13 (2.5)
0.75 (1.0)	17 (1)	13 (2.5)	17 (1)	13 (2.5)
1.1 (1.5)	17 (1)	9 (6)	17 (1)	9 (6)
1.5 (2.0)	15 (1.5)	9 (6)	17 (1)	9 (6)
2.2 (3.0)	13 (2.5)	9 (6)	17 (1)	9 (6)
3 (4.0)	11 (4)	7 (10)	15 (1.5)	7 (10)
4 (5.0)	11 (4)	7 (10)	11 (4)	7 (10)
5.5 (7.5)	11 (4)	7 (10)	11 (4)	7 (10)
7.5 (10)	7 (10)	2 (35)	7 (10)	2 (35)
11 (15)	5 (16)	2 (35)	16 (5)	2 (35)
15 (20)	5 (16)	2 (35)	5 (16)	2 (35)
18.5 (25)	3 (25)	2 (35)	5 (16)	2 (35)
22 (30)	2 (35)	2 (35)	2 (35)	2 (35)
30 (40)	0 (50)	-5 (150)	0 (50)	-5 (150)
37 (50)	-2 (70)	-5 (150)	-2 (70)	-5 (150)
45 (60)	-2 (70)	-5 (150)	-3 (95)	-5 (150)

**Table 6. Cable Cross-Sections for Input Voltage Range
3Ø AC 380V through 480V.**

Maximum Output rating kW (hp)	Input Power Cable		Motor Cable	
	Minimum Cross-Section AWG (mm ²)	Maximum Cross-Section AWG (mm ²)	Minimum Cross-Section AWG (mm ²)	Maximum Cross-Section AWG (mm ²)
0.37 (.50)	17 (1)	13 (2.5)	17 (1)	13 (2.5)
0.55 (.75)	17 (1)	13 (2.5)	17 (1)	13 (2.5)
0.75 (1.0)	17 (1)	13 (2.5)	17 (1)	13 (2.5)
1.1 (1.5)	17 (1)	13 (2.5)	17 (1)	13 (2.5)
1.5 (2.0)	17 (1)	13 (2.5)	17 (1)	13 (2.5)
2.2 (3.0)	17 (1)	9 (6)	17 (1)	9 (6)
3 (4.0)	17 (1)	9 (6)	17 (1)	9 (6)
4 (5.0)	17 (1)	9 (6)	17 (1)	9 (6)
5.5 (7.5)	13 (2.5)	7 (10)	13 (2.5)	7 (10)
7.5 (10)	11 (4)	7 (10)	11 (4)	7 (10)
11 (15)	9 (6)	7 (10)	9 (6)	7 (10)
15 (20)	7 (10)	2 (35)	7 (10)	2 (35)
18.5 (25)	7 (10)	2 (35)	7 (10)	2 (35)
22 (30)	5 (16)	2 (35)	5 (16)	2 (35)
30 (40)	3 (25)	2 (35)	3 (25)	2 (35)
37 (50)	3 (25)	2 (35)	2 (35)	2 (35)
45 (60)	2 (35)	-5 (150)	2 (35)	-5 (150)
55 (75)	-2 (70)	-5 (150)	-2 (70)	-5 (150)
75 (100)	-2 (70)	-5 (150)	-3 (95)	-5 (150)
90 (125)	-2 (70)	-5 (150)	-3 (95)	-5 (150)

**Table 7. Cable Cross-Sections for Input Voltage Range
3Ø AC 500V through 600V.**

Maximum Output rating kW (hp)	Input Power Cable		Motor Cable	
	Minimum Cross-Section AWG (mm ²)	Maximum Cross-Section AWG (mm ²)	Minimum Cross-Section AWG (mm ²)	Maximum Cross-Section AWG (mm ²)
0.75 (1.0)	17 (1)	7 (10)	17 (1)	7 (10)
1.1 (1.5)	17 (1)	7 (10)	17 (1)	7 (10)
1.5 (2.0)	17 (1)	7 (10)	17 (1)	7 (10)
2.2 (3.0)	17 (1)	7 (10)	17 (1)	7 (10)
3 (4.0)	17 (1)	7 (10)	17 (1)	7 (10)
4 (5.0)	17 (1)	7 (10)	17 (1)	7 (10)
5.5 (7.5)	15 (1.5)	7 (10)	15 (1.5)	7 (10)
7.5 (10)	13 (2.5)	7 (10)	13 (2.5)	7 (10)
11 (15)	11 (4)	7 (10)	11 (4)	7 (10)
15 (20)	9 (6)	2 (35)	9 (6)	2 (35)
18.5 (25)	9 (6)	2 (35)	9 (6)	2 (35)
22 (30)	7 (10)	2 (35)	7 (10)	2 (35)
30 (40)	5 (16)	2 (35)	5 (16)	2 (35)
37 (50)	3 (25)	2 (35)	5 (16)	2 (35)
45 (60)	3 (25)	-5 (150)	3 (25)	-5 (150)
55 (75)	0 (50)	-5 (150)	2 (35)	-5 (150)
75 (100)	-2 (70)	-5 (150)	0 (50)	-5 (150)
90 (125)	-2 (70)	-5 (150)	0 (50)	-5 (150)

Input Power Connection



DANGER:

- **As supplied, the SED2 must be grounded** (per IEC 536, Class 1, NEC and other relevant industry standards). Extremely hazardous conditions can occur if the SED2 is not correctly grounded.
- Use only permanently wired input power connections. Only hard-wired input power connections are permissible. Use Class 1 60/75° copper wire only.
- The cross-section of the ground-bonding conductor must be at least equal to the input power cables.
- The following terminals can carry hazardous voltages even when the SED2 is not running:
 - Input power terminals: L1, L2, L3
 - Motor terminals: U, V, W
 - Link terminals: DC-, DC+/B+, DC/R+, B- (not for customer use)

Connect input power to SED2 terminals L1, L2, and L3 (Figures 19 through 22).

Motor Cable Length

Maximum motor cable length is 164 ft (50m). Motor cable length is given to ensure performance of only the SED2, not the suitability of the motor when connected to a SED2 at this distance.

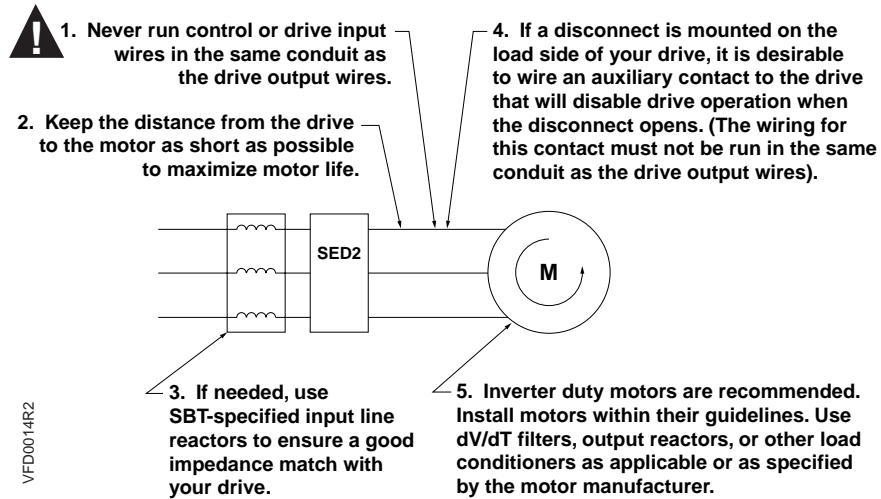

Figure 23. Motor Cable Installation Notes.

NOTE: If connecting multiple motors to one SED2, the total length of the individual motor cables must not exceed the maximum motor cable length.

Motor Connection (Wye "Y"/Star or Delta Configuration)



DANGER:

Do not use the SED2 with a motor of higher nominal power rating than the SED2, or a nominal power less than half that of the SED2. Only operate the SED2 when the nominal current (P0305) is set to match motor rating continuous current.

The motor nameplate indicates the required supply voltage and method of connection. In general, larger 400/690V motors connect in a delta (Δ) configuration and smaller 230/400V motors connect in a Wye "Y" or star configuration (Figure 24).

Connect motor wiring to SED2 terminals U, V, and W (Figures 19 through 22).

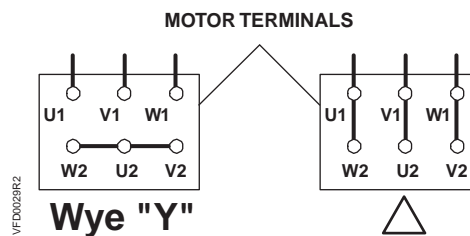

Figure 24. Delta and Star (Wye, Y) Motor Connections.

Direction of Motor Rotation

To change the direction of motor rotation, cross-connect two of the output conductors on the SED2 (Figure 25). This is the desired method for changing rotation.

NOTE: The Reverse Output Phase Sequence parameter (P1820) can also reverse the direction of rotation. However, if the SED2 is reset to factory defaults, P1820 is reset to OFF.

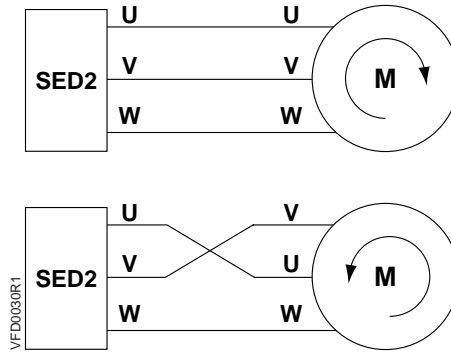

Figure 25. Direction of Motor Rotation.

Motor Overload Protection



WARNING:

The SED2 is capable of providing internal motor overload protection in accordance with UL508C, Section 42. Accurately configure motor parameters for the motor overload protection to operate correctly. See Motor I²t Temperature Reaction parameter (P0610); I²t is On by default.

Motor overload protection also can be provided using an external PTC temperature-thermistor sensor (disabled by default via Motor Temperature Sensor parameter (P0601)).

During operation below nominal speed, the cooling effect of the fans mounted to the motor shaft is reduced. Therefore, most motors require de-rating if operated continuously at low frequencies. To ensure that motors are protected from overheating under these conditions, mount a PTC temperature-thermistor sensor to the motor and connect it to the control terminals of the SED2.

NOTE: To enable the switch-off function with a PTC temperature-thermistor sensor, set Motor Temperature Sensor parameter (P0601) to 1 for PTC temperature-thermistor sensor. Use a shielded cable to connect the PTC temperature-thermistor sensor.

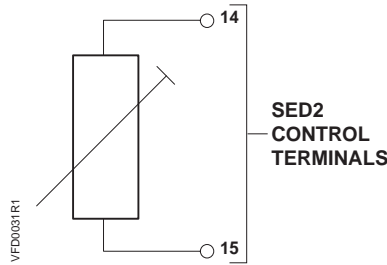

Figure 26. External Motor Overload Protection.

Connection of Multiple Motors

The SED2 can control several motors in parallel as long as all of the motors have the same power rating. When multiple motors connect to the SED2 in parallel, the motors cannot operate individually.

NOTES:

1. When determining the required power, take into account the total current from all the motors (or the total of all ratings).
2. The sum of all individual motor cable lengths must not exceed the maximum motor cable length.

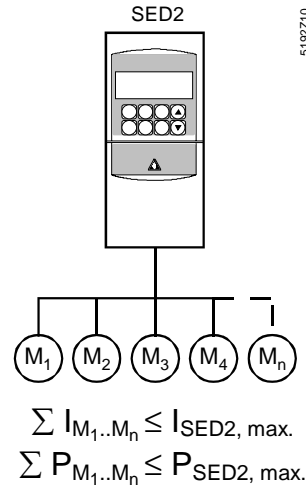

Figure 27. SED2 Connection to Multiple Motors.

Analog Input DIP Switches



WARNING:

When using analog inputs, the DIP switches must be correctly set and the analog inputs correctly configured before being enabled. If this is not done, the motor may start inadvertently.

After completing settings for motor frequency and unit of measurement DIP switches, and wiring for input power and motor connections, reattach the I/O module.

For all versions of the SED2, the DIP switches used to configure the analog inputs are located on the I/O module. (See *Access to Connection Terminals* section for disassembly instructions.)

DIP Switch	Position	Function
1	OFF	Analog Input 1, voltage 0 to 10 Vdc, factory default.
	OFF	Analog Input 1, Ni 1000 sensor input with parameter setting P0756[0]=5.
	ON	Analog Input 1, current 0 to 20 mA.
2	OFF	Analog Input 2, voltage 0 to 10 Vdc, factory default.
	OFF	Analog Input 2, Ni 1000 sensor input with parameter setting P0756[1]=5.
	ON	Analog Input 2, current 0 to 20 mA.

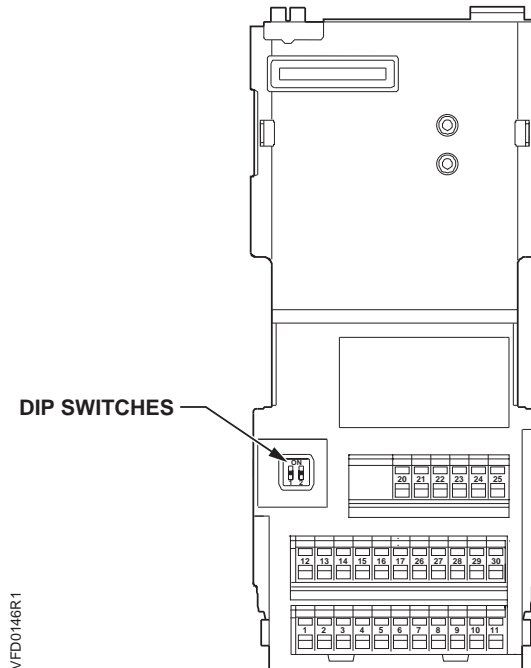

Figure 28. Location of Analog Input DIP Switches on I/O Module.

Control Terminal Connections

Control Terminal Layout

The control terminals (Figures 29 and 30) are located on the I/O module. The I/O module is identical for all versions of the SED2. The I/O module is located under the operator panel. (See the *Access to Connection Terminals* section for disassembly instructions.)

Connect control wiring to SED2 control terminals 1 through 30 per site-specific drawings. See the *Analog and Digital I/O Control Terminal Connections* section for examples of connections.

NOTE:

1. Use only shielded cables for control cables.
2. Route control cables in separate cable trunks at least 7-3/4 inches (20 cm) away from motor and power cables.

After completing analog input DIP switch settings and wiring for control terminal connections, reattach the SED2 cover and operator panel.

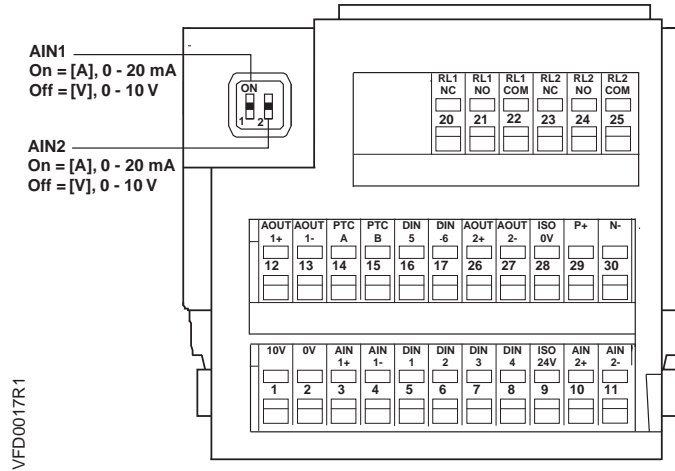

Figure 29. SED2 Control Terminals on I/O Module.

- NOTES:**
1. Analog inputs 1 and 2 can be optionally configured for direct connection of a Ni 1000 temperature sensor. The sensor connects between terminals 4 and 2 or 11 and 2.
 2. 0 to 10 Vdc analog inputs connect between terminals 2 and 3.
 3. 0 mA to 20 mA and 4 mA to 20 mA analog inputs connect between terminals 3 and 4.
When using a 4 mA to 20 mA input, DIP switches must be set to appropriate input.

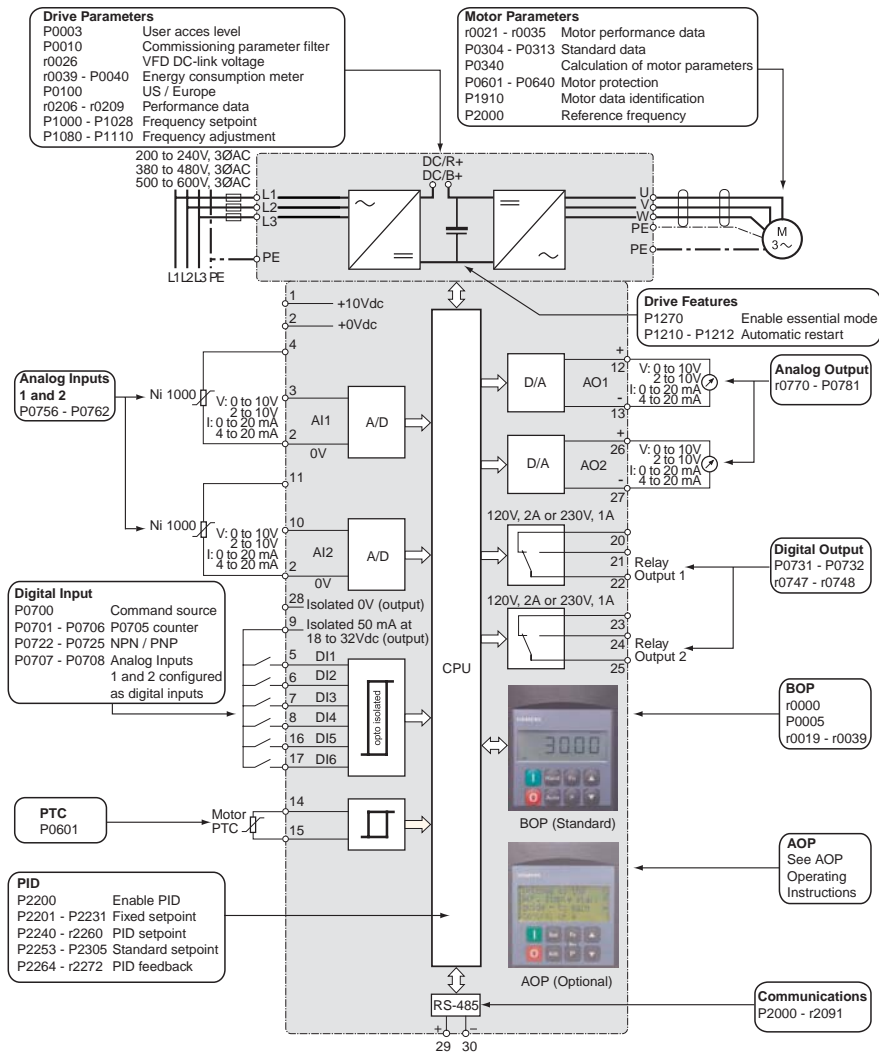

Figure 30. SED2 Terminal Connections and Related Parameters.

Analog and Digital I/O Control Terminal Connections

Figures 31 through 35 show typical analog and digital input/output control terminal connections.



WARNING:

When using analog inputs, the DIP switches must be correctly set and the analog inputs correctly configured before enabling them. If this is not done, the motor may start inadvertently.

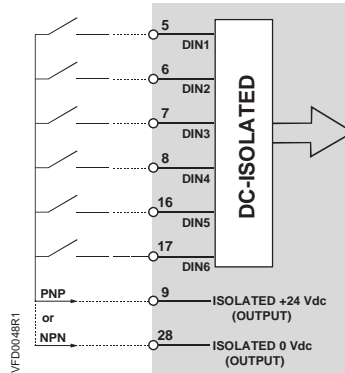

Figure 31. Digital Inputs 1 through 6.

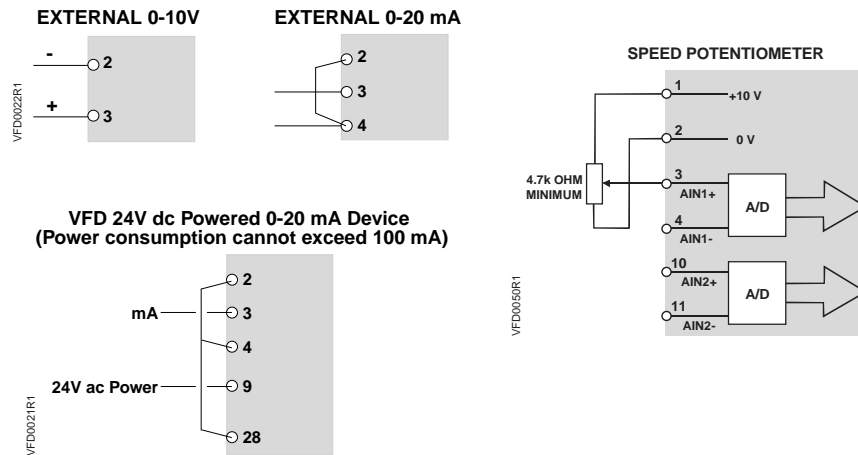

Figure 32. Analog Inputs 1 and 2.

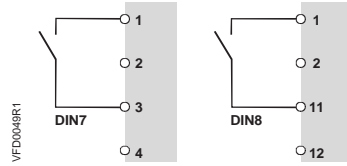

Figure 33. Connection of Analog Inputs 1 and 2 as Digital Inputs 7 and 8.

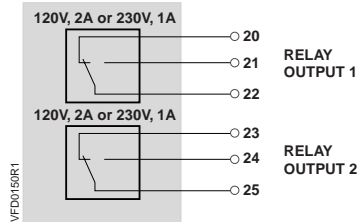

Figure 34. Digital Outputs 1 and 2.

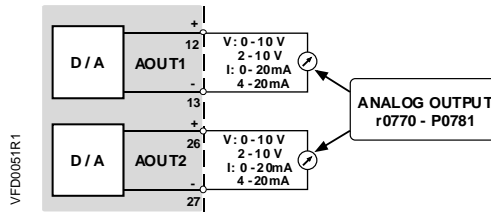

Figure 35. Analog Outputs 1 and 2.

Parameters

Overview

The SED2 uses parameters to define the required operating characteristics, such as motor data, ramp times, and maximum and minimum frequency. Users enter and modify the SED2 parameters using the Basic Operator Panel, the Advanced Operator Panel, or a serial interface.

Each parameter consists of the letter "r" or "P", followed by four numbers, such as r0000 or P0010. The letter "r" identifies read-only parameters. The letter "P" identifies programmable parameters.

Parameter Structure

Figure 36 depicts the structure of the SED2 parameters.

- User Access Level parameter (P0003) selects the *access level* for using the parameters (1=standard, 2=extended, or 3=expert). The access level selected via parameter P0003 determines the number of parameters that are accessible by the user. For most applications, the Standard (1) and Extended (2) levels are sufficient. The factory default setting is P0003=1 (Standard).
- The *filters* of Parameter Filter parameter (P0004) categorize the parameters that are available via the access level according to functionality. The filters/categories enable a more focused operational approach. If parameter P0004=0 for no filter/category, then all parameters for a selected user access level are available.

NOTE: Some parameters are intended for commissioning only and can be viewed as a function of this filter. In order to set these parameters, P0010 must be set to **1** (quick commissioning).

Parameter Indexes

Certain parameters have indexes. The indexes provide subsets of a particular parameter function and group together closely related parameter type information. The *Parameter Reference Guide* (Document Number 125-3214) lists any indexes associated with a parameter.

The following indexes are associated with P0700, P1000, and digital input and output parameters:

- IN000 (AUTO), 1st command data set (CDS)
- IN001 (HAND), 2nd command data set (CDS)

The following indexes are associated with analog input and output parameters:

- IN000, Analog input 1, AO1
- IN001, Analog input 2, AO2

NOTE: Throughout this manual, a parameter number followed by [0] or [1] denotes index number 000 or 001 respectively.

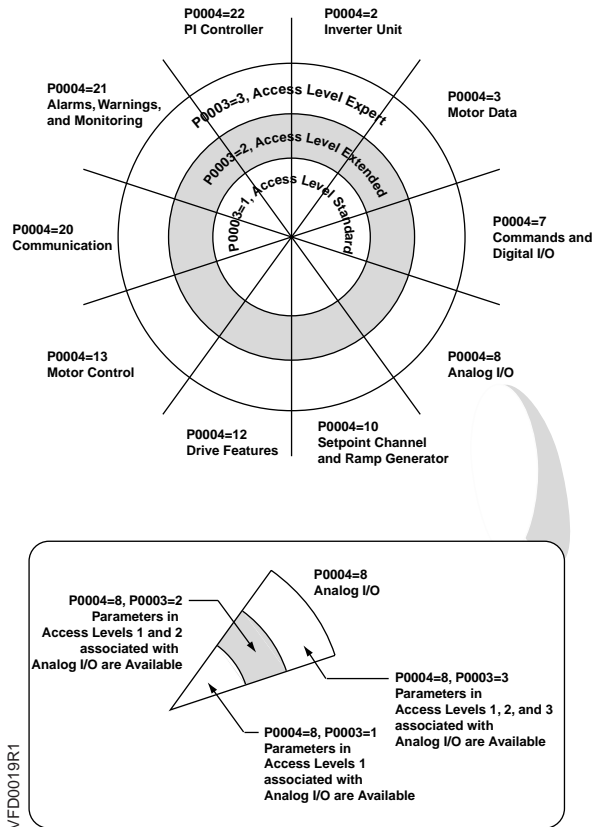

Figure 36. SED2 Parameter Access Levels and Filters.

SED2 Operator Panels

Overview

The SED2 includes the Basic Operator Panel (BOP) mounted as standard. An Advanced Operator Panel (AOP) is available as an option.



Figure 37. Basic Operator Panel (BOP).



Figure 38. Advanced Operator Panel (AOP).

NOTES:

1. On initial startup, the SED2 display values alternate between 0.0 Hz (zero) and the speed it would be running if it were given a start command.
2. The BOP or AOP can connect to or disconnect from the SED2 without switching off power.

Basic Operator Panel (BOP)

The BOP provides access to the parameters of the SED2 and allows for application-specific settings of the SED2.







The parameters and measured values are shown in a 5-digit LCD display. The BOP can mount directly onto the SED2 or, alternatively, it can mount into a control cabinet door using a special installation kit (SED2-DOOR-KIT1 or SED2-DOOR-KIT2).



The BOP cannot store parameter data.

Advanced Operator Panel (AOP)

For information on the AOP, see the *AOP Operating Instructions* (Document Number 125-3206). AOP features include a real-time clock, ability to upload/download parameter sets, and control of a network of up to 31 drives.

BOP Display and Pushbuttons

Operator Panel/Button	Function	Description
	Status display	The LCD (five-digit display for BOP; multi-line, clear-text display for AOP) displays the settings presently used by the SED2 or used to set parameters in the SED2.
	Start motor	Press this pushbutton to start the SED2. As part of the factory setting, this pushbutton is enabled for manual mode.
	Stop motor	OFF1 Press this pushbutton to stop the SED2 within the selected ramp-down time. As part of the factory setting, this pushbutton is enabled for manual mode. OFF2 Press this pushbutton twice (or once with sustained pressure) to cause the motor to coast freely to a standstill. This function is enabled in the manual and automatic operating modes.
	Change to manual control	Places the SED2 in HAND mode.
	Change to automatic control	Places the SED2 in AUTO mode.
	Increase value	Press this pushbutton to increase the current display value during parameter setting. In manual mode, this pushbutton increases the speed (internal motor potentiometer).
	Decrease value	Press this pushbutton to decrease the current display value during parameter setting. In manual mode, this pushbutton decreases the speed (internal motor potentiometer).

Operator Panel/Button	Function	Description
	Access to parameters	<p>Press this pushbutton to do one of the following:</p> <ul style="list-style-type: none"> • Access the parameters. • Exit a parameter by accepting its value.
	Functions	<p>Press this pushbutton to display additional information.</p> <p>Press and hold this pushbutton for three seconds for a quick view display.</p> <p>Press this pushbutton repeatedly to display DC-V/A/Hz/V. Press and hold this pushbutton for three seconds to return to normal view.</p> <p>Multiple display mode: When you press this pushbutton for three seconds with power applied, the following information displays:</p> <ul style="list-style-type: none"> • DC link voltage (indicated by d – units V) • Output current (A) • Output frequency (Hz) • Output voltage (indicated by o – units V) <p>Repeatedly press the pushbutton to cycle through these display items. Press this pushbutton again for a sustained time to exit the multiple display mode.</p> <p>The value selected in P0005 (Drive Display for r0000 parameter). If P0005 is configured to display any of these items (1 to 4), the value does not redisplay.</p> <p>Jump function: You can jump from any parameter (rXXXX or PXXXX) directly to r0000 (Drive Display parameter) by briefly pressing the Fn pushbutton. This allows you to modify another parameter if required. After jumping to r0000, press the Fn pushbutton again to return to the starting point.</p>

NOTES:

1. If you attempt to modify a parameter that cannot be modified under the current conditions (for example, a parameter that cannot be modified during operation or that can only be modified in the Quick Commissioning mode), the display reads:



2. Busy Signal — While changing parameters, the BOP can display:

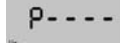

for a maximum of 5 seconds. This display means that the SED2 is busy with higher-priority activities.

3.  Displays when SED2 is processing information and will not respond to input actions until processing is complete.

Commissioning

**WARNING:**

- Only authorized personnel trained in the setup, installation, commissioning, and operation of the SED2 may work on the product and mechanical system.
- SED2s operate at high voltages. In some components, operation of electrical equipment involves using dangerous voltages.
- In cases where faults in the control equipment could cause significant equipment damage or severe physical injury (such as potentially dangerous short circuits), use external precautions to ensure and to enforce safe operation (such as independent limit switches and mechanical interlocks).
- Emergency stop facilities must remain functional in all operating modes of the control equipment. Resetting the emergency stop facility must not result in an uncontrolled or undefined restart. Do not use the SED2 as an emergency stop mechanism.
- The equipment incorporates internal motor overload protection in accordance with UL508C, Section 42. See Motor I²t Temperature Reaction parameter (P0610); I²t is ON by default. (Motor overload protection can also be provided with an external PTC temperature-thermistor sensor disabled by default via Motor Temperature Sensor parameter (P0601). See the *Motor Overload Protection* section in this manual for details.) For reliable motor overload protection, the motor parameters must be configured accurately.
- Certain parameter settings can cause the SED2 to start automatically or to restart automatically after a fault or an input power failure (provided the fault is eliminated or acknowledged or the supply voltage is restored).

Motor Nameplate Data for Parameter Settings

You can modify motor data via the parameter settings only if Commissioning Parameter Filter P0010=1, for the quick commissioning procedure.

Motor control via the BOP is enabled in Hand mode by default. To enable motor control via the BOP during the quick commissioning procedure, set Selection of Command Source parameter P0700[0]=1 (for BOP) and Selection of Frequency Setpoint P1000[0]=1 (for motor potentiometer setpoint).

If the BOP is configured for control (P0700[0]=1 for BOP), the motor stops when the BOP is removed.

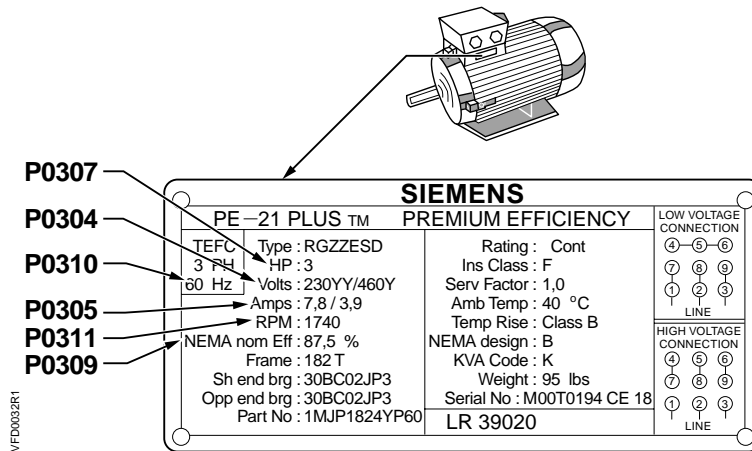

Figure 39. Motor Nameplate Data for Commissioning Parameters.

Prerequisites to Startup Procedure

To ensure reliable SED2 operation and to avoid any extra costs related to loss or reduction of warranty coverage, a factory certified specialist should complete this startup procedure.

Complete the following checklist and maintain it in a secure location as service personnel may request this information.



CAUTION:

The SED2 has no isolating switch on the input power and is live as soon as the input power is connected. The SED2 remains with the output disabled until you press  (green start pushbutton) or until it receives a digital On command signal.

Check	Step
-------	------

- | | |
|-----|-------------------------------------------------------------------------------------------------------------------------------------------------------------------------------------------------------------------------------------------------------------------------------------|
| () | 1. The SED2 is thoroughly tested at the factory. Verify that the SED2 is free of shipping and installation damage. Shipping damage is not covered by the Siemens Building Technologies, Inc. warranty; claims must be filed directly with the shipping company as soon as possible. |
| () | 2. Verify that the model numbers and the voltage ratings are as specified in the purchase order by matching the nameplate data of each unit to the purchase order. |
| () | 3. Review the appropriate sections of this manual and verify that the mechanical and electrical installation procedures are complete. |

Review any option instructions and job schematics provided with the SED2.



CAUTION:

Failure to comply with mechanical and electrical installation requirements may void the product warranty.

- | | |
|-----|------------------------------------------------------------------------------------------------------------------------------------------------------------------------------------------|
| () | 4. Verify that the 50/60 Hz DIP switch has been set to the appropriate setting, as instructed in the <i>Motor Frequency and Unit of Measurement DIP Switches</i> section of this manual. |
|-----|------------------------------------------------------------------------------------------------------------------------------------------------------------------------------------------|

- () 5. Inspect the security of the input power wiring, ground connections, motor wiring, and all control circuit connections, as identified in the SED2 documentation.
- IMPORTANT:** Verify that the cross-section and length of the input power and motor cables are correct.
- IMPORTANT:** Confirm that the input power connects to the SED2 input terminals: **(L1, L2, L3)**
- and NOT to the output motor terminals: **(U, V, W)**.
- IMPORTANT:** Verify that all input power wires (L1, L2, L3) and motor wires (U, V, W) are securely tightened down to their lugs. Loose wire connections may cause problems at any time, and are not covered under warranty.
- () 6. Review the installer's as-wired schematic. Determine where the motor safety circuit is connected. Verify that the customer's emergency contacts are properly terminated in the SED2 safety shutdown circuit or bypass option.
- Verify that all other field-installed wires are correctly terminated (including the shields).
- () 7. Verify the motor is free to move mechanically.
- () 8. For pump applications, verify the medium (such as water) is available (no dry run).
- () 9. Record the motor(s) nameplate information:
- Voltage: Service Factor:
- Efficiency %: Full Load Amps (FLA):
- RPM: Hp:
- () 10. Verify that the input power voltage matches the rating of the SED2.
- () 11. Verify that the *motor* is wired for the application voltage.
- () 12. **IMPORTANT:** Verify that the motor rated full load amps (FLA) does NOT exceed the rated output current of the SED2 controlling it.
- When multiple motors are simultaneously operated by the SED2, the sum of all motor rated FLA values must be less than or equal to that of the SED2 controlling them.

- () 13. Record any other connections to the SED2 by terminal number to determine if special programming is required.
Record any changes in *Appendix A: Parameters, Defaults, and Settings*.
- () 14. Make certain the immediate area around the SED2 is free of debris and miscellaneous items.
- () 15. If applicable, verify that the building automation system logic is ready to perform adequately for start, stop, and speed command functions.





This concludes the preparation process for SED2 startup.

Keep this manual, option schematics, and any other instructions sent with the SED2 easily accessible to assist you through the remainder of this startup process.

SED2 (stand-alone) Startup Procedure

NOTE: For SED2 with bypass option, see the documentation provided with bypass for startup instructions.

Check Step

- () 1. Make sure that all three power phases are present and that the input voltage is correct for the SED2 being started.
Apply SED2 power and verify that the SED2 display is on.
If the display indicates a fault, press  to reset it.
- () 2. Perform quick commissioning according to the *Quick Commissioning Procedure* section in this manual.
On completion of the quick commissioning procedure, proceed to step 3.
- () 3. Press  and  to return to the SED2 operating mode.
Press  to place SED2 in Hand mode.
- () 4. To start the SED2, press  (green start pushbutton). The SED2 will ramp up to 10 Hz (or minimum speed). Verify that the direction of motor rotation is correct.



CAUTION:

If the direction of motor rotation is wrong, **turn power Off!**



DANGER:

Wait for 5 minutes. Always wait 5 minutes after disconnecting the SED2 from the power source before performing any work. The DC link capacitors of all SED2s remain charged with dangerous voltages for 5 minutes after all supplies have been disconnected. When working on open equipment, note that live parts are exposed. Do not touch these parts.

Swap wires on the motor terminals (**U, V**) or on the output terminals of the motor overload relay. Tighten the terminal lugs, reapply power, and recheck the direction of motor rotation.

- () 5. With correct motor rotation, manually run the SED2 throughout its entire operating range while observing operation.

If the SED2 trips on over-current during acceleration, increase the acceleration time rate via parameter P1120.

If the SED2 trips on over-voltage during deceleration, adjust the deceleration time rate via parameter P1121.

If excessive vibration of the driven load is noted at specific frequencies, use Skip Frequency parameters P1091 through P1094 to eliminate this vibration.
- () 6. Determine whether the remote speed reference is a 0 to 10 Vdc or a 4 to 20 mA signal. Connect or verify connection of signal wires. Set or verify that analog input DIP switch has been set to the appropriate setting as instructed in the *Analog Input DIP Switches* section of this manual.
- () 7. Check the signal for proper polarity. Observe if the remote speed command can achieve the minimum and maximum speeds desired. If not, scale as required. The signal value can be read at r0752 and the scaled value can be read at r0754.
- () 8. Make additional SED2 application parameter settings as required and record them in *Appendix A: Parameters, Defaults, and Settings*.
- () 9. Press  to place SED2 in Auto mode.

This completes the startup procedure for the SED2.





Quick Commissioning Procedure









Parameter P0010 is the Commissioning Parameter Filter. It allows you to select a group of parameters that can be used for quick commissioning, including motor data (Figure 39), and motor ramp-up and ramp-down settings.













It is important to use parameter P0010 to commission the SED2, P0003 to select the access level for using parameters, and P0004 to filter the parameters according to their functionality. When Commissioning Parameter Filter P0010=1, it initiates the quick commissioning procedure.

It is recommended that you use the quick commissioning procedure. However, experienced users may commission the equipment without the P0004 filter functions.









At the end of the quick commissioning procedure, set parameter P3900=1. This setting performs the necessary motor calculations and sets all remaining parameters (those not included in P0010=1) to the factory default values. If P3900 is set to a value greater than 0, P0010 is automatically reset to 0. (If P0010=1, the SED2 cannot start.) The process of performing motor calculations and setting all parameters to factory default values is only possible via quick commissioning.

Parameter	Description	Action	Setting/ Default
P0003	<p>User Access Level</p> <p>Allows you to access more parameters.</p> <p>1 = Standard 2 = Extended 3 = Expert</p>	<ol style="list-style-type: none"> 1. Press  to access parameter r0000 and to enter the SED2 parameter mode. 2. Press  to advance to parameter P0003. 3. Press  to access the parameter values level. 4. Press  to advance to 3 (expert level). 5. Press  to confirm and save the P0003=3 setting. 	<p>Setting = 3</p> <p>Default = 1</p>
	<p>NOTE:</p> <ol style="list-style-type: none"> 1. Before starting quick commissioning, set P0003=3 to ensure all necessary parameters are available during quick commissioning. 		









Parameter	Description	Action	Setting/ Default
P0010	<p>Quick Commissioning</p> <p>0 = Ready to Run 1 = Quick Commissioning 30 = Factory Setting</p>	<ol style="list-style-type: none"> 1. Press  to access parameter r0000 and to enter the SED2 parameter mode. 2. Repeatedly press  to advance to parameter P0010. 3. Press  to access the parameter values level. 4. Press  to advance to 1. 5. Press  to confirm and save the P0010=1 setting. 	<p>Setting = 1</p> <p>Default = 0</p>
<p>NOTES:</p> <ol style="list-style-type: none"> 1. P0010 <i>must always</i> be set back to 0 before operating the motor. 2. If P3900 is greater than 0 on completion of commissioning, P0010 is automatically set back to 0. 			
P0100	<p>Operation for Europe/ N. America</p> <p>0 = 50 Hz, kW (Europe), factory default 1 = 60 Hz, hp (North America) 2 = 60 Hz, kW (North America)</p> <p>The setting of Motor Frequency and Unit of Measurement DIP switch 2 overrides P0100 settings 0 and 1. See the <i>Motor Frequency and Unit of Measurement DIP Switch Settings</i> section in this manual for details.</p>	<ol style="list-style-type: none"> 1. Press  to advance to parameter P0100. 2. Press  to access the parameter values level. 3. Press  to advance to 1. 4. Press  to confirm and save the P0100=1 setting. 	<p>Setting = 1</p> <p>Default = 0 or 1</p> <p>(Default is determined by the setting of the Motor Frequency and Unit of Measurement DIP switches.)</p>
<p>NOTES:</p> <ol style="list-style-type: none"> 1. Stop the SED2 (that is, disable all pulses) before changing this parameter. 2. Changing P0100 resets all rated motor parameters as well as other parameters that depend on the rated motor parameters (such as P0340, Calculation of Motor Parameters). 			

Parameter	Description	Action	Setting/ Default
P0304 *	<p>Rated Motor Voltage</p> <p>10V to 2000V</p> <p>Rated motor voltage (V) from motor nameplate.</p>	<ol style="list-style-type: none"> 1. Press  to advance to parameter P0304. 2. Press  to access the parameter values level. 3. Press  to advance to nominal voltage. 4. Press  to confirm and save the setting. 	<p>Motor nameplate</p> <p>Default = Varies by model</p>
P0305 *	<p>Rated Motor Current</p> <p>0A to 10,000A</p> <p>Rated motor current (A) from motor nameplate.</p>	<ol style="list-style-type: none"> 1. Press  to advance to parameter P0305. 2. Press  to access the parameter values level. 3. Press  to advance to nominal current. 4. Press  to confirm and save the setting. 	<p>Motor nameplate</p> <p>Default = Varies by model</p>
P0307 *	<p>Rated Motor Power</p> <p>0 kW or hp to 2000 kW or hp</p> <p>Rated motor power (kW or hp) from motor nameplate.</p> <p>If P0100=1 (60 Hz, hp, North America), then motor power is in hp.</p>	<ol style="list-style-type: none"> 1. Press  to advance to parameter P0307. 2. Press  to access the parameter values level. 3. Press  to advance to nominal power. 4. Press  to confirm and save the setting. 	<p>Motor nameplate</p> <p>Default = Varies by model</p>











* Motor related parameters.

Parameter	Description	Action	Setting/ Default
P0308 *, or P0309 *	<p>Rated Motor cosPhi (P0308), or Rated Motor Efficiency (P0309)</p> <p>0.000 to 1.000 (P0308) or 0.0 to 99.9 (P0309)</p> <p>Rated motor cosPhi or motor efficiency from motor nameplate.</p> <p>If P0100=0 or 2 and P0307=kW, P0308 displays; if P0100=1 and P0307=hp, P0309 displays.</p> <p>P0309=100% corresponds to superconducting.</p> <p>NOTE: This parameter is available when P0003 = 3 and P0010 = 1.</p>	<ol style="list-style-type: none"> 1. Press  to advance to parameter P0308 or P0309. 2. Press  to access the parameter values level. 3. Press  to advance to nominal cosPhi or motor efficiency. 4. Press  to confirm and save the setting. 	<p>Motor nameplate</p> <p>P0308 Default = 0.000</p> <p>P0309 Default = varies (hp/voltage dependent)</p>
P0310 *	<p>Rated Motor Frequency</p> <p>12 Hz to 650 Hz</p> <p>Rated motor frequency (Hz) from motor nameplate.</p> <p>Pole pair number is recalculated automatically if the parameter is changed.</p>	<ol style="list-style-type: none"> 1. Press  to advance to parameter P0310. 2. Press  to access the parameter values level. 3. Press  to advance to nominal frequency (60 Hz). 4. Press  to confirm and save the setting. 	<p>Motor nameplate 60 Hz</p> <p>Default = 50 Hz/ 60 Hz</p> <p>Default is dependent on the setting of the Motor Frequency and Unit of Measurement DIP switches.</p>











* Motor related parameters.

Parameter	Description	Action	Setting/ Default
P0311 *	<p>Rated Motor Speed</p> <p>0 to 40,000 1/min</p> <p>Rated motor speed (rpm) from motor nameplate.</p> <p>A setting of 0 causes an internal calculation of this value.</p> <p>Vector control and V/f control with speed controller require this value.</p> <p>Slip compensation in V/f control requires this value for correct operation.</p> <p>Pole pair number is recalculated automatically if the parameter is changed.</p>	<ol style="list-style-type: none"> 1. Press  to advance to parameter P0311. 2. Press  to access the parameter values level. 3. Press  to advance to nominal motor speed. 4. Press  to confirm and save the setting. 	<p>Motor nameplate</p> <p>Default = 0</p>
P0640	<p>Motor Overload Factor</p> <p>10% to 400%</p> <p>Limited to the maximum SED2 output current rating or to 400% of the rated current (P0305), whichever is lower.</p> <p>NOTE: This parameter is available when P0003 = 3 and P0010 = 1.</p>	<ol style="list-style-type: none"> 1. Press  to advance to parameter P0640. 2. Press  to access the parameter values level. 3. Press  to advance to desired value. 4. Press  to confirm and save the setting. 	<p>Site setting</p> <p>Default = 110</p>













* Motor related parameters.









Parameter	Description	Action	Setting/ Default
P0700[0] **	<p>Selection of Command Source (Start Command)</p> <p>Selects the command source as follows:</p> <p>0 = Factory default setting 1 = BOP (keypad) 2 = Terminal digital input 4 = USS on BOP link (AOP) 5 = USS on COM link 6 = CB (communications board or module) on COM link (P1/N2)</p>	<ol style="list-style-type: none"> 1. Press  to advance to parameter P0700. 2. Press  to access the parameter indexes. 3. Press  to advance to index [0], IN000, AUTO. 4. Press  to confirm index selection. 5. Press  to advance to 2. 6. Press  to confirm and save the setting. 	<p>Setting = 2</p> <p>Default = 2</p>
<p>NOTE: Changing this parameter resets (to default) all setting on the selected item. For example, changing from 1 to 2 resets all digital inputs to default settings.</p>			
P0700[1] **	<p>Selection of Command Source (Start Command)</p> <p>Selects the command source as follows:</p> <p>0 = Factory default setting 1 = BOP (keypad) 2 = Terminal digital input 4 = USS on BOP link (AOP) 5 = USS on COM link 6 = CB (communications board or module) on COM link (P1/N2)</p>	<ol style="list-style-type: none"> 1. Press  to advance to index [1], IN001, HAND. 2. Press  to confirm index selection. 3. Press  to advance to 1. 4. Press  to confirm and save the setting. 5. Press  again to return to the parameter selection level. 	<p>Setting = 1</p> <p>Default = 1</p>
<p>NOTE: Changing this parameter resets (to default) all setting on the selected item. For example, changing from 1 to 2 resets all digital inputs to default settings.</p>			

** Parameters have two index settings: IN000=Auto and IN001=Hand.

Parameter	Description	Action	Setting/ Default
P1000[0] **	<p>Selection of Frequency Setpoint (Speed Command Source)</p> <p>Selects the frequency setpoint source as follows:</p> <ul style="list-style-type: none"> 1 = Motor potentiometer setpoint/ BOP keypad 2 = Analog input 3 = Fixed frequency setpoint 4 = USS on BOP Link/AOP 5 = USS on COM link 6 = CB (communications board or module) on COM link/ P1-N2 communications 	<ol style="list-style-type: none"> 1. Press  to advance to parameter P1000. 2. Press  to access the parameter indexes. 3. Press  to advance to index [0], IN000, AUTO. 4. Press  to confirm index selection. 5. Press  to advance to 2. 6. Press  to confirm and save the setting. 	<p>Setting = 2</p> <p>Default = 2</p>
P1000[1] **	<p>Selection of Frequency Setpoint (Speed Command Source)</p> <p>Selects the frequency setpoint source as follows:</p> <ul style="list-style-type: none"> 1 = Motor potentiometer setpoint/ BOP keypad 2 = Analog input 3 = Fixed frequency setpoint 4 = USS on BOP Link/AOP 5 = USS on COM link 6 = CB (communications board or module) on COM link/ P1-N2 communications 	<ol style="list-style-type: none"> 1. Press  to advance to index [1], IN001, HAND. 2. Press  to confirm index selection. 3. Press  to advance to 1. 4. Press  to confirm and save the setting. 5. Press  again to return to the parameter selection level. 	<p>Setting = 1</p> <p>Default = 1</p>

** Parameters have two index settings: IN000=Auto and IN001=Hand.





Parameter	Description	Action	Setting/ Default
P1080	<p>Minimum Motor Frequency</p> <p>0 Hz to 650 Hz</p> <p>Minimum motor frequency at which the motor will run irrespective of the frequency setpoint. This value applies to both clockwise and counterclockwise rotation.</p>	<ol style="list-style-type: none"> 1. Press  to advance to parameter P1080. 2. Press  to access the parameter values level. 3. Press  to advance to desired value. 4. Press  to confirm and save the setting. 	<p>Site Setting</p> <p>(20-30% Max)</p> <p>Default = 10</p>
P1082	<p>Maximum Motor Frequency</p> <p>0 Hz to 650 Hz</p> <p>Maximum motor frequency at which the motor will run regardless of the frequency setpoint. This value applies to both clockwise and counterclockwise rotation.</p>	<ol style="list-style-type: none"> 1. Press  to advance to parameter P1080. 2. Press  to access the parameter values level. 3. Press  to advance to desired value. 4. Press  to confirm and save the setting. 	<p>Site Setting</p> <p>Default = 50 or 60</p> <p>(Default is determined by the setting of the Motor Frequency and Unit of Measurement DIP switches.)</p>
<p>NOTE:</p> <p>This value is limited internally to 200 Hz or five times the rated motor frequency (P0305) when P1300 is greater than or equal to 20 (control mode=vector control). The value displays via r0209 (maximum frequency).</p>			
P1120	<p>Ramp-up Time</p> <p>0s to 650s</p>	<ol style="list-style-type: none"> 1. Press  to advance to parameter P1120. 2. Press  to access the parameter values level. 3. Press  to advance to desired value. 4. Press  to confirm and save the setting. 	<p>Site Setting</p> <p>Default = 10</p> <p>Typical fan = 120s.</p> <p>Typical pump = 30s.</p>
<p>NOTES:</p> <ol style="list-style-type: none"> 1. Setting the ramp-up time too short can cause the SED2 to trip (F0001 overcurrent, F0002 overvoltage, or F0003 undervoltage). 2. If using an external frequency setpoint with set ramp rates (such as from a PLC), achieve optimum SED2 performance by setting ramp times (P1120 and P1121) slightly shorter than those of the PLC. 			











Parameter	Description	Action	Setting/ Default
P1121	<p>Ramp-down Time</p> <p>0s to 650s</p>	<ol style="list-style-type: none"> 1. Press  to advance to parameter P1121. 2. Press  to access the parameter values level. 3. Press  to advance to desired value. 4. Press  to confirm and save the setting. 	<p>Site Setting</p> <p>Default = 30</p> <p>Typical fan = 120s.</p> <p>Typical pump = 30s.</p>
<p>NOTES:</p> <ol style="list-style-type: none"> 1. Setting the ramp-up time too short can cause the SED2 to trip (F0001 overcurrent, F0002 overvoltage, or F0003 undervoltage). 2. If using an external frequency setpoint with set ramp rates (such as from a PLC), achieve optimum SED2 performance by setting ramp times (P1120 and P1121) slightly shorter than those of the PLC. 			
P3900	<p>End Quick Commissioning</p> <p>0 = End without motor calculation or factory reset.</p> <p>1 = End with motor calculation and factory reset (recommended on SED2 <i>without</i> bypass option).</p> <p>2 = End with motor calculation and with I/O reset (recommended on SED2 <i>with</i> bypass option).</p> <p>3 = End with motor calculation but without I/O reset.</p>	<ol style="list-style-type: none"> 1. Press  to advance to parameter P3900. 2. Press  to access the parameter values level. 3. Press  to advance to 1. 4. Press  to confirm the setting. 	<p>Setting = 1</p> <p>Default = 0</p>
<p>NOTES:</p> <ol style="list-style-type: none"> 1. P0010 <i>must always</i> be set back to 0 before operating the motor. 2. If P3900 is less than 0 on completion of commissioning, P0010 is automatically set back to 0. 			

Additional Parameter Settings

NOTE: If Display Selection for r0000, parameter P0005=21 (actual frequency), then the BOP display alternately shows setpoint values and the actual value (0 Hz).

Flying Start

Parameter	Description	Action	Setting/ Default
P1200	<p>Flying Start</p> <p>Starts SED2 into a spinning motor by rapidly changing the output frequency of the SED2 until the actual motor speed is found. Then, the motor runs up to setpoint using the normal ramp time.</p> <p>0 = Flying start disabled 1 = Flying start is always active, start in direction of setpoint 2 = Flying start is active if power on, fault, OFF2, start in direction of setpoint 3 = Flying start is active if fault, OFF2, start in direction of setpoint 4 = Flying start is always active, only in direction of setpoint 5 = Flying start is active if power on, fault, OFF2, only in direction of setpoint 6 = Flying start is active if fault, OFF2, only in direction of setpoint</p>	<ol style="list-style-type: none"> 1. Press  to enter the SED2 parameter mode and to display r0000. 2. Press  to advance to parameter P1200. 3. Press  to access the parameter values level. 4. Press  to advance to desired setting. 5. Press  to confirm and save the setting. 	Minimum: 0 Default: 0 Maximum: 6
<p>NOTES:</p> <ol style="list-style-type: none"> 1. Flying start is useful for motors with high inertia loads. 2. Settings 1 to 3 search in both directions. Settings 4 through 6 search only in direction of setpoint. 3. Flying start must be used in cases where the motor may still be turning (such as after a brief input power break) or can be driven by the load. Otherwise, overcurrent trips occur. 4. If the SED2 faults on F0002 (overvoltage) on a start command, flying start may have to be optimized by reducing the values in P1203 and P1202. 			





Parameter	Description	Action	Setting/ Default
P1202	<p>Motor Current: Flying Start</p> <p>Defines search current used for flying start. Value is in % based on the rated motor current (P0305).</p>	<ol style="list-style-type: none"> 1. Press  to enter the SED2 parameter mode and to display r0000. 2. Press  to advance to parameter P1200. 3. Press  to access the parameter values level. 4. Press  to advance to desired value. 5. Press  to confirm and save the setting. 	<p>Minimum: 10</p> <p>Default: 100</p> <p>Maximum: 200</p>
<p>NOTE:</p> <p>Reducing the search current may improve performance for flying start if the inertia of the system is not very high.</p>			
P1203	<p>Search Rate: Flying Start</p> <p>Sets factor by which the output frequency changes during flying start to synchronize with the turning motor. This value, entered in % relative to the default time factor, defines the initial gradient and influences the time taken to search for the motor frequency.</p> <p>The search time is the time taken to search through all frequencies between $f_{max} + 2 \times f_{slip}$ to 0 Hz.</p>	<ol style="list-style-type: none"> 1. Press  to enter the SED2 parameter mode and to display r0000. 2. Press  to advance to parameter P1202. 3. Press  to access the parameter values level. 4. Press  to advance to desired value. 5. Press  to confirm and save the setting. 	<p>Minimum: 10</p> <p>Default: 100</p> <p>Maximum: 200</p>
<p>NOTES:</p> <ol style="list-style-type: none"> 1. P1203=100% is defined as giving a rate of 2% of $f_{slip,nom}/ms$. 2. P1203=200% would result in a rate of frequency change of 1% of $f_{slip,nom}/ms$. 3. A higher value produces a flatter gradient, and thus a longer search time. A lower value has the opposite effect. 			















Automatic Restart







CAUTION:

Setting 2 through 5 can cause the motor to restart unexpectedly.





Parameter	Description	Action	Setting/ Default
P1210	<p>Automatic Restart</p> <p>Enables SED2 restart after a supply power break or after a fault.</p> <p>0 = Disabled 1 = Trip reset after power on (P1211 disabled) 2 = Restart after supply power blackout (P1211 disabled) 3 = Restart after brownout or fault (P1211 enabled) 4 = Restart after supply power brownout (P1211 disabled) 5 = Restart after blackout or fault (P1211 disabled)</p>	<ol style="list-style-type: none"> 1. Press  to enter the SED2 parameter mode and to display r0000. 2. Press  to advance to parameter P1210. 3. Press  to access the parameter values level. 4. Press  to advance to desired setting. 5. Press  to confirm and save the setting. 	<p>Minimum: 0</p> <p>Default: 1</p> <p>Maximum: 5</p> <p>Setting: 3</p>
<p>NOTES:</p> <ol style="list-style-type: none"> 1. Auto restart requires a constant ON command (such as via a digital input). 2. P1200 flying start must be used in cases where the motor may still be turning, such as after a brief input power break, or can be driven by the load. 3. A supply power brownout is when the power is interrupted and reapplied before the operator panel display has gone dark. It is a very short supply power break where the DC link has not fully collapsed 4. A supply power blackout is when the operator panel display has gone dark before the power is reapplied. It is a long supply power break where the DC link has fully collapsed. 			

Parameter	Description	Action	Setting/ Default
P1211	Number of Restart Attempts Specifies number of times SED2 will attempt to restart after supply power brownout or fault, if P1210 automatic restart is activated.	<ol style="list-style-type: none"> 1. Press  to enter the SED2 parameter mode and to display r0000. 2. Press  to advance to parameter P1211. 3. Press  to access the parameter values level. 4. Press  to advance to desired value. 5. Press  to confirm and save the setting. 	Minimum: 0 Default: 3 Maximum: 10
P1212	Time to First Restart Selects the time (seconds) before the SED2 is restarted for the first time if P1210 automatic restart is activated	<ol style="list-style-type: none"> 1. Press  to enter the SED2 parameter mode and to display r0000. 2. Press  to advance to parameter P1212. 3. Press  to access the parameter values level. 4. Press  to advance to desired value. 5. Press  to confirm and save the setting. 	Minimum: 0 Default: 30 Maximum: 1000
P1213	Restart Time Increment Selects the amount (seconds) that the restart time is incremented for each restart of the SED2 if P1210 automatic restart is activated	<ol style="list-style-type: none"> 1. Press  to enter the SED2 parameter mode and to display r0000. 2. Press  to advance to parameter P1213. 3. Press  to access the parameter values level. 4. Press  to advance to desired value. 5. Press  to confirm and save the setting. 	Minimum: 0 Default: 30 Maximum: 1000









Vdc Controller

Parameter	Description	Action	Setting/ Default
P1240	<p>Configuration of Vdc Controller</p> <p>Enables/disables Vdc controller.</p> <p>The Vdc controller dynamically controls the DC link voltage to prevent overvoltage trips on high inertia systems.</p> <p>Vdc-max automatically increases ramp-down times to keep the DC link voltage (r0026) within limits.</p> <p>0 = Vdc controller disabled 1 = Vdc-max controller enabled 2 = Reserved 3 = Reserved</p>	<ol style="list-style-type: none"> 1. Press  to enter the SED2 parameter mode and to display r0000. 2. Press  to advance to parameter P1240. 3. Press  to access the parameter values level. 4. Press  to advance to desired value. 5. Press  to confirm and save the setting. 	<p>Minimum: 0</p> <p>Default: 1</p> <p>Maximum: 3</p>

Pulse Frequency

Parameter	Description	Action	Setting/ Default
P1800	<p>Pulse Frequency</p> <p>Sets pulse frequency (kHz) of power switches in SED2. The frequency can be changed in increments of 2 kHz.</p> <p>Pulse frequencies > 4 kHz selected on 380V to 480V units reduce the maximum continuous motor current.</p> <p>NOTES:</p> <ol style="list-style-type: none"> 1. Minimum pulse frequency depends on P1082 (maximum frequency) and P0310 (rated motor frequency). 2. At 4 kHz, full output current is obtained up to 50 degrees C (CT mode); over 50 degrees C, full output may be obtained at 8 kHz. 3. If silent operation is not absolutely necessary, lower pulse frequencies may be selected to reduce SED2 losses and radio-frequency emissions. 4. Under certain circumstances, the SED2 may reduce the switching frequency to provide protection against over-temperature. 	<ol style="list-style-type: none"> 1. Press  to enter the SED2 parameter mode and to display r0000. 2. Press  to advance to parameter P1800. 3. Press  to access the parameter values level. 4. Press  to advance to desired value. 5. Press  to confirm and save the setting. 	<p>Minimum: 2</p> <p>Default: Varies by model (hp/voltage dependent)</p> <p>Maximum: 16</p>

Reset to Factory Defaults

Parameter	Description	Action	Setting/ Default
P0010 P0970	<p>Reset to Factory Default</p> <p>Resets SED2 parameters to the factory defaults.</p>	<ol style="list-style-type: none"> 1. Press  to enter the SED2 parameter mode and to display r0000. 2. Press  to advance to parameter P1010. 3. Press  to access the parameter values level. 4. Press  to advance to 30. 5. Press  to confirm and save the setting. 6. Press  to go to parameter P0970. 7. Press  to advance to 1. 8. Press  to confirm and save the setting. 	<p>P0010: Setting = 30 Default = 0</p> <p>P0970: Setting = 1 Default = 0</p>
<p>NOTES:</p> <ol style="list-style-type: none"> 1. First set P0010=30. 2. Stop SED2 (that is, disable all pulses) before you reset parameters to factory default values. 3. The following parameters retain their values after a factory reset: <ul style="list-style-type: none"> • P0918 (address of CB, communications board or module) • P2010 (USS baud rate) • P2011 (USS address) 4. The reset process takes about 10 seconds. 5. <i>Appendix A: Parameters, Defaults, and Settings</i> lists SED2 parameters and their factory defaults. 			

Network Communications

Table 8 lists the parameters required for correct APOGEE™ system FLN communications and control of the SED2.



CAUTION:

Changes made to the parameters other than what is listed in Table 8 can result in damaging the drive or building equipment.

Table 8. Parameters for Network Communications.

Parameter	Value
P0003: User access Level	Set to 3 to allow access to required parameters.
P2040: CB telegram off time	Set to 0 (watchdog disabled) to tell the SED2 to start looking for communication via the setting of P2041.
P2041[0]: CB parameter	Set to 1 for FLN (P1) control. (Set to 2 for FLN (N2) control.)
P0918: CB address	Set to 99 for (P1) addressing of the device. (Set to 3 for (N2) addressing of the device.) Unit must be powered down to establish P1 communications, and then the address is assigned. The address will return to the default of 99 when the drive is powered down.
P0700[0]	Set to 6 tells the SED2 to look for a start command from the network in the auto mode.
P1000[0]	Set to 6 tells the SED2 to look for its speed source from the network in the auto mode.









Since there is a limited life to EEPROM writes, set the Network Fault Indicator to **0** only when troubleshooting a communications problem.

If a factory reset of parameters is desired, set P0010 to **30** and then set P0970 to **1**.

Appendix B: SED2 Point Maps provides a SED2 P1 point map for APOGEE® Automation Systems and a SED2 N2 point map for Johnson Controls, Inc. systems.

Changing Individual Parameter Digits

To quickly change the value of a parameter, modify the individual digits in the display as follows:

1. Verify that you are at the parameter values level by following these steps:
 - a. Press  to enter the parameter level.
 - b. Press  to advance to the desired parameter.
 - c. Press  to access the parameter values level.
2. Press  the right-most digit starts to flash.
3. Modify the value of this digit with the  and  pushbuttons.
4. Press  again. The next digit starts flashing.
5. Repeat steps 3 and 4 until the required value displays.
6. Press  to exit the parameter values level.

Maintenance

Perform SED2 maintenance semi-annually. Estimated maintenance time is one hour.

Prerequisites

1. Confer with customer and log any comments about specific SED2s.
2. Verify with customer that SED2 can be serviced and explain the service steps.
3. Document last trip error (if any).
4. Verify SED2 Emergency Services are de-energized.
5. De-energize unit.
6. Follow standard lockout, tag-out procedures and verify that input power is removed.

General Inspection and Cleaning

NOTE: See the appropriate sections in this manual for mechanical and electrical installation instructions.

1. Open unit.
2. Inspect unit and verify that all connections have continuity.
3. Visually inspect unit for signs of arcing or overheating.
4. Vacuum and dust unit interior using a non-static generating device.
5. Verify environmental conditions conform to drive specifications.
6. Inspect outer casing for cleanliness and corrosion.

Muffin Fan Inspection and Cleaning

1. Clean dirt or debris from fan housing and blades.
2. Check fan bearings.
 - You should not be able to move the blades forward or backward.
 - The blades should free wheel and not appear to be binding.

- There should be no mechanical whining sound made from the fan
3. Close unit.
 4. Remove lockout, tag-out materials.

Re-energize Unit

1. Verify 3-phase power supply is within SED2 ratings.
2. Check for input phase balance legs: A to B, B to C, and C to A. Phase balance should be within 10V to 15V of each other.

DC Bus Integrity Test

1. At this time, the SED2 should have power applied but not be enabled to run.
2. Check the Actual DC Link Voltage using parameter r0026 index 000 and 001.
 - With index 000 displayed, there should be no more than a 25V fluctuation.
 - With index 001 displayed, there should be no more than a 25V fluctuation.

Contactors and Switches

Verify with infrared temperature that no hot spots have occurred in contactors and switches.

Motor Bearing Wear

To determine motor bearing wear, use an amphere probe at 60 Hz on SED2 motor output leads to document full running amps.

Troubleshooting

Reading Faults

- OK FAULT (r0052, bit 3) is a read-only fault status point (0=OK, 1=Fault).
- LAST FAULT (r0947(0)) shows the code for the most recent fault. Fault history displays according to Figure 40, where:

F1 = The first active fault (not yet acknowledged)

F2 = The second active fault (not yet acknowledged)

F1e = The occurrence of the fault acknowledgement for F1 and F2.

This moves the value in the two indexes down to the next pair of indexes, where they are stored. Indexes 0 and 1 contain the active faults. When faults are acknowledged, indexes 0 and 1 are reset to 0.

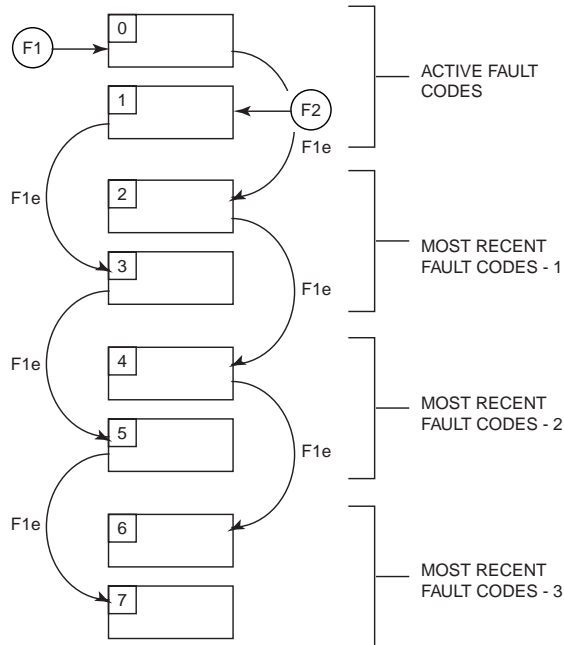

Figure 40. Display of Fault History.

- For example:
If the SED2 trips on undervoltage and then receives an external trip before the undervoltage is acknowledged, you will obtain:

Index 0 = 3, undervoltage
Index 1 = 85, external trip

Whenever a fault in index 0 is acknowledged (F1e), the fault history shifts as indicated in the diagram.

- Indexes:
r0947[0] = Recent fault trip –, fault 1
r0947[1] = Recent fault trip –, fault 2
r0947[2] = Recent fault trip -1, fault 3
r0947[3] = Recent fault trip -1, fault 4
r0947[4] = Recent fault trip -2, fault 5
r0947[5] = Recent fault trip -2, fault 6
r0947[6] = Recent fault trip -3, fault 7
r0947[7] = Recent fault trip -3, fault 8

Index 2 is used only if a second fault occurs before the first fault is acknowledged.

Resetting Faults

- Press **Fn** to reset a fault condition manually.
- OK FAULT (r0052, bit 3) is a read-only fault status point (0=OK, 1=Fault). It can be acknowledged with FAULT ACK (r0054, bit 7). Setting FAULT ACK (r0054, bit 7) resets the fault (1=Reset Fault).
- It is possible that motor performance may be affected at low frequencies if parameter P1310 falls under 50% (default value).
- It is recommended to make provision to reset faults automatically if the unit is operated in auto mode.

Troubleshooting the Operator Panel

If the display shows \mathcal{P} - - - - or it is a blank screen, make certain connection pins are not bent on the I/O module (Figure 41) and that connection openings on the back of the operator panel are free from obstructions (Figure 42).

NOTE: For Frame Size D through F, verify ribbon cable connector is not loose or damaged. Verify functionality of the operator panel by plugging it directly into the control module.

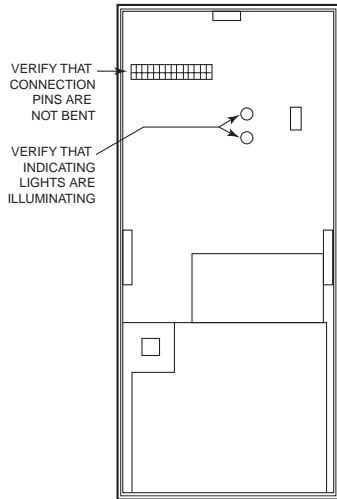

Figure 41. Connection Pins on I/O Module.

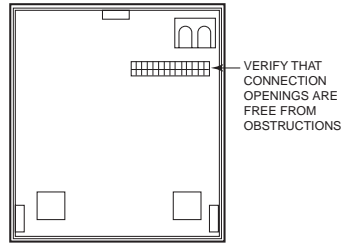

Figure 42. Connection Openings on Back Side of Operator Panel.

Troubleshooting Using the Operator Panel

NOTE: The voltage and current range of the SED2 must match the motor data.

If the motor does not start with the ON command:

1. Check if Commissioning Parameter Filter P0010=0 (factory setting).
2. Check if there is a valid ON signal.
3. Check if Selection of Command Source parameter P0700[0]=2 (for digital input control) or P0700[1]=1 (for BOP control).
4. Check if the correct setpoint is available (0 to 10V on terminal 3), or if the setpoint was entered in the correct location for the setpoint source (Selection of Frequency Setpoint parameter P1000[0]=2).

If the motor does not start after checking these parameters, reset the SED2 to the factory-default parameter values according to the *Reset to Factory Defaults* section in this manual.

Use a switch between terminals **5** and **9** on the control terminal bar. The SED2 should now run according to the default setpoint at the analog input.

Use r0722 to check on/off status of digital inputs. Use r0752 to check the smoothed value of analog inputs.

Fault Codes

Error	Cause	Diagnosis/Remedy	Drive Reaction
F0001, Overcurrent	<ul style="list-style-type: none"> • Motor power (P0307) is greater than SED2 power (P0206). • Motor lead short circuit. • Ground faults. • Motor is pulling more current than rating because of mechanical issues. 	<ul style="list-style-type: none"> • Motor power (P0307) SED2 power (P0206). • Cable length limits must not be exceeded. • Short circuits or ground faults in motor cable and motor. • Motor parameters must match the motor in use. • Value of stator resistance (P0350) must be correct. • Motor is obstructed or overloaded. • Increase ramp-up time. • Reduce boost level. 	Off2

Error	Cause	Diagnosis/Remedy	Drive Reaction
F0002, Overvoltage	<ul style="list-style-type: none"> • DC link voltage (r0026) exceeds trip level. • Overvoltage can be caused either by the input supply voltage being too high or if motor is in regenerative mode. • Regenerative mode can be caused by fast ramp downs or if the motor is driven from an active load. 	<ul style="list-style-type: none"> • Supply voltage must lie within the limits indicated on the SED2 rating plate. • DC link voltage controller must be enabled (P1240) and parameterized correctly. • Ramp-down time (P1121) must match inertia of load. • Loose wire on output. • Set P1800=2 to reduce pulse size. • Review quick commissioning with User Access Level P0003=3 (expert) and specify a value for P0309, rated motor efficiency. • On systems with multiple motors, one may be pushing the other. • System electrical disturbance may need correction. • If the SED2 faults on F0002 (overvoltage) on a start command, flying start may have to be optimized. This is typically done by reducing the values in P1203 and P1202. <p>NOTE: Higher inertia requires long ramp-down times.</p>	Off2
F0003, Undervoltage	<ul style="list-style-type: none"> • Input power supply failed. • Shock load outside the specified limits. 	<ul style="list-style-type: none"> • Supply voltage must lie within the limits indicated on the SED2 rating plate. • Supply voltage must not be susceptible to temporary failures or voltage reductions outside tolerance. • Use Ramp-up Time P1120 to increment the ramp-up time. 	Off2

Error	Cause	Diagnosis/Remedy	Drive Reaction
F0004, SED2 over-temperature	<ul style="list-style-type: none"> • Ventilation is inadequate. • Fan is inoperative. • The ambient temperature is too high. 	<ul style="list-style-type: none"> • Fan must turn when the SED2 is running. • Pulse frequency must be set to a lower value. • Ambient temperature could be higher than specified for the SED2. 	Off2
F0005, SED2 I ² t	<ul style="list-style-type: none"> • The SED2 is overloaded. • Duty cycle is outside the tolerance. • Motor power (P0307) exceeds the SED2 power (P0206). 	<ul style="list-style-type: none"> • Load cycle must lie within the limits specified. • Motor power (P0307) ≤ SED2 power (P0206). 	Off2
F0011, Motor over-temperature	<ul style="list-style-type: none"> • Motor is overloaded • Protection is too finely tuned for the duty cycle. • Rated Motor Efficiency P0309 is not accurate. 	<ul style="list-style-type: none"> • Make sure that the load duty cycle (temporary overload) lies within the limits specified. • Verify P0640 is set for the application. • Verify motor efficiency setup via P0309 equals motor nameplate data. <p>NOTE: Set P0003=3 and P0010=1 and then advance to P0309. Set efficiency to motor rated efficiency, or 99. Advance to P3900=3.</p>	Off2
F0012, SED2 temperature signal lost	Wire breakage of the SED2 temperature sensor (heat sink).	—	Off2
F0015, Motor temperature signal lost	<ul style="list-style-type: none"> • Breakage or short-circuit of the motor temperature sensor. • If a signal loss is detected, temperature monitoring switches to monitoring the thermic motor image. 	—	Off2
F0020, 1 phase for input power supply missing	One of the 3 phases of the input power supply voltage is missing.	Check wiring of the 3 phases at the SED2 input supply voltage.	Off2

Error	Cause	Diagnosis/Remedy	Drive Reaction
F0021, Ground fault	<p>The ground fault occurs if the sum of the phase currents is higher than 5% of the nominal SED2 current.</p> <p>NOTE: This error message occurs on SED2s with three current sensors; that is, for SED2s of frame sizes D to F.</p>	—	Off2
F0022, Power stack fault	<p>The fault is caused by the following events:</p> <p>(1) dc link overcurrent = short circuit of IGBT.</p> <p>(2) short circuit of dc link chopper</p> <p>(3) ground fault.</p> <p>Frame sizes A to C = (1),(2),(3).</p> <p>Frame sizes D to E = (1),(2).</p> <p>Frame size F = (2).</p> <p>Since all these faults are assigned to one signal on the power stack, it is not possible to establish which one actually occurred.</p>	<ul style="list-style-type: none"> • Check for loose output or short. • Possible drive component failure. 	Off2
F0023, Fault at SED2 output	On-phase is interrupted at the SED2 output.	—	Off2
F0024, Rectifier over-temperature	<ul style="list-style-type: none"> • Ventilation is inadequate. • Fan is inoperative. • Ambient temperature is too high. 	<ul style="list-style-type: none"> • Fan must turn when the SED2 is running. • Pulse frequency (P1800) must be set to default value 4 kHz. 	—
F0030, Fan fault	Fan no longer works.	<ul style="list-style-type: none"> • Fault cannot be masked while the options module (BOP or AOP) is connected. • Replace the fan. 	Off2

Error	Cause	Diagnosis/Remedy	Drive Reaction
<p>F0041, Motor data identification failure</p>	<ul style="list-style-type: none"> • Motor data identification failed • Alarm value = 0: Load is missing • Alarm value = 1: Current limit value reached during identification. • Alarm value = 2: Identified stator resistance less than 0.1% or more than 100%. • Alarm value = 3: Identified rotor resistance less than 0.1% or more than 100%. • Alarm value = 4: Identified stator reactance less than 50% or more than 500%. • Alarm value = 5: Identified input power reactance less than 50% or more than 500%. • Alarm value = 6: Identified rotor time constant less than 10 ms or more than 5s. • Alarm value = 7: Identified total leakage reactance less than 5% or more than 50%. • Alarm value = 8: Identified stator leakage reactance less than 25% or more than 250%. • Alarm value = 9: Identified rotor leakage reactance less than 25% or more than 250%. <p>(Continued)</p>	<p>0: Check if the motor is connected to the SED2.</p> <p>1-40: Check if the motor data in P0304 to P0311 are correct.</p> <p>Check the type of motor wiring required (star, delta).</p>	<p>Off2</p>

Error	Cause	Diagnosis/Remedy	Drive Reaction
(Continued) F0041, Motor data identification failure	<ul style="list-style-type: none"> Alarm value = 20: Identified IGBT ON-voltage less than 0.5 or more than 10V. Alarm value = 30: Current controller at voltage limit. Alarm value = 40: Inconsistency of identified data set, at least one identification failed. <p>Percentage values based on impedance</p> $Z_b = \frac{V_{mot,nom}}{\sqrt{3} \cdot I_{mot,nom}}$	<p>0: Check if the motor is connected to the SED2.</p> <p>1-40: Check if the motor data in P0304 to P0311 are correct.</p> <p>Check the type of motor wiring required (star, delta).</p>	Off2
F0051, Parameter EEPROM fault	Read or write failure while saving non-volatile parameter	Reset SED2 to factory setting and perform quick commissioning.	Off2
F0052, Power stack fault	Read failure for power stack information or invalid data.	Replace SED2.	Off2
F0053, I/O EEPROM fault	Read failure for I/O EEPROM information or invalid data.	<ul style="list-style-type: none"> Check the data. Replace the I/O module. 	Off2
F0054, Wrong I/O connection	I/O connection is invalid.	<ul style="list-style-type: none"> Check data flow. Replace I/O module. 	Off2
F0060, ASIC timeout	Internal communication error.	<ul style="list-style-type: none"> If error reappears, replace SED2. Contact your supplier. 	Off2
F0070, CB setpoint fault	No setpoints from CB (communications board or module) during telegram off time.	Check CB (communications board or module) and communications partner.	Off2
F0071, USS (BOP link) setpoint fault	No setpoints from USS during telegram off time.	<ul style="list-style-type: none"> Check communications to data transmission module. Check USS master. 	Off2
F0072, USS (COM link) setpoint fault	No setpoints from USS during telegram off time	Check USS master.	Off2

Error	Cause	Diagnosis/Remedy	Drive Reaction
F0080, Analog input signal lost	<ul style="list-style-type: none"> • Broken wire at analog input. • Signal level outside defined limits. 	—	Off2
F0085, External fault	External fault triggered via input terminals.	<ul style="list-style-type: none"> • Disable input terminals for fault trigger, or eliminate external fault. • Check if digital input is set to ON. 	Off2
F0101, Stack overflow	Software or processor error.	Run self-test routines.	Off2
F0221, PID feedback below min. value	PID feedback below minimum value of P2268, minimum value for PID feedback.	<ul style="list-style-type: none"> • Change value of P2268. • Adjust feedback amplification. 	Off2
F0222	PID feedback above maximum value.	<ul style="list-style-type: none"> • PID feedback, maximum value of P2267 (maximum value for PID feedback). • Adjust feedback amplification. 	Off2
F0450, BIST tests failure	Alarm value: <ol style="list-style-type: none"> 1. Some power section tests have failed. 2. Some control module tests have failed. 4. Some functional tests have failed. 8. Some I/O module tests have failed. 16. Internal RAM failed on power-up check. 	<ul style="list-style-type: none"> • SED2 may run, but some functions do not work properly. • Replace the SED2. 	Off2

Error	Cause	Diagnosis/Remedy	Drive Reaction
F0452, Belt failure detected	Load condition changes at the motor indicate a belt failure or mechanical fault.	<ul style="list-style-type: none"> • Motor belt OK? Is the motor obstructed or seized? • If external speed sensor is used, check proper function. Also check: <ul style="list-style-type: none"> — P0409 (pulses/sec at rated frequency) — P2191 (belt failure speed tolerance monitoring) — P2192 (delay time for P2191). • For belt failure detection without sensor, check: <ul style="list-style-type: none"> — P2182 (threshold frequency f1) — P2183 (threshold frequency f2) — P2184 (threshold frequency f3) — P2185 (upper torque threshold 1) — P2186 (lower torque threshold 1) — P2187 (upper torque threshold 2) — P2188 (lower torque threshold 2) — P2189 (upper torque threshold 3) — P2190 (lower torque threshold 3) — P2192 (delay for belt failure). • Lubricate the motor if necessary. 	Off2

Warning Messages

Error	Cause	Diagnosis and Remedy	Drive Reaction
A0501, Current limit	<ul style="list-style-type: none"> • Motor power>SED2 power. • Motor cables are too long. • Ground faults. 	<ul style="list-style-type: none"> • Check belt tension. • Motor power (P0307) >SED2 power (P0206). • Cable length limits must not be exceeded. • Motor cable and motor must not have short circuits or ground faults. • Motor parameters must match the motor in use. • Value of stator resistance (P0350) must be correct. • The motor must not be obstructed or overloaded. • Check belt tension, if applicable. • Increase ramp-up time. • Reduce boost level. 	—
A0502, Overvoltage limit	<p>Overvoltage limit is reached.</p> <p>This warning may appear on ramp-down if the DC link is disabled (P1240 = 0).</p>	<p>If this warning is displayed permanently, check the SED2 input voltage or extend the ramp-down time for the SED2.</p>	—
A0503, Undervoltage limit	<p>Input power failed.</p> <p>The input power and consequently the DC link voltage (r0026) are below the defined threshold value.</p>	<p>Check input supply voltage.</p>	—
A0504, SED2 over-temperature	<p>The warning level of the SED2 heat sink temperature (r0037) is exceeded.</p> <p>This results in a reduced pulse frequency and/or a reduced output frequency (dependent on parameter setting in (P0610).</p>	<ul style="list-style-type: none"> • The ambient temperature must lie within the limits specified. • The load conditions and duty cycle must lie within the specified conditions. • The fan must turn when the SED2 is running. 	—

Error	Cause	Diagnosis and Remedy	Drive Reaction
A0505, SED2 I ² t	Warning level exceeded. The current supply is reduced if parameter P0610=1.	Check that the duty cycle lies within the limits specified. Motor power (P0307)>SED2 power (P0206).	—
A0506, SED2 duty cycle	Difference between the heat sink temperature and IGBT exceeds the warning levels.	Make sure that the load duty cycles (temporary overload) lie within the limits specified.	—
A5011, Motor over-temperature I ² t	<ul style="list-style-type: none"> • Motor is overloaded. • Duty cycle is outside the tolerance. 	<ul style="list-style-type: none"> • Correct overload. • Adjust duty cycle. • Re-run quick commissioning. • Verify motor efficiency setup via P0309 equals motor nameplate data. <p>NOTE: Set P0003=3 and P0010=1 and then advance to P0309. Set efficiency to motor rated efficiency, or 99. Advance to P3900=3.</p>	—
A0520, Rectifier over-temperature	Warning level of the rectifier heat sink temperature is exceeded.	<ul style="list-style-type: none"> • Ambient temperature must lie within the limits specified. • Load conditions and duty cycle must lie within the specified conditions. • Fan must turn when the SED2 is running. 	—
A0523, SED2 output fault	On-phase is interrupted at the SED2 output.	—	—
A0541, Motor data identification enabled	Motor data identification (P1910) selected or running.	—	—
A0600, RTOS data loss	—	—	—

Error	Cause	Diagnosis and Remedy	Drive Reaction
A0910, Vdc (max.) controller disabled	<ul style="list-style-type: none"> • Vdc maximum controller disabled as not able to keep the DC link voltage (r0026) within threshold limits. • Permanent supply overvoltage. • Occurs if the motor is driven by a load forcing the motor to go into energy recovery operation. • Occurs during ramp-down of very high duty cycles. 	<ul style="list-style-type: none"> • Input voltage must lie within specified range. • Load must be adjusted. • In some cases, brake resistance must be applied. 	—
A0911, Vdc (max.) controller enabled	<p>Vdc maximum controller is enabled.</p> <p>Ramp-down times are increased automatically to keep the DC link voltage (r0026) within the limits specified.</p>	Increase ramp-down time.	—
A0912, Vdc (min) controller enabled	<ul style="list-style-type: none"> • Vdc minimum controller enabled if the DC link voltage (r0026) drops below the minimum value. • Motor kinetic energy is used to buffer the DC link voltage and thus slow the SED2. • Temporary supply failures do not automatically lead to undervoltage shutdown. 	—	—
A0920, Analog input parameters not set properly	<ul style="list-style-type: none"> • Analog input parameters must not be set to identical values, as illogical values would result. • Index 0: Parameter settings for output identical. • Index 1: Parameter settings for input identical. • Index 2: Parameter settings for input do not correspond to analog input type. 	—	—

Error	Cause	Diagnosis and Remedy	Drive Reaction
A0921, Analog output parameters not set properly	<ul style="list-style-type: none"> • Analog output parameters must not be set to identical values, as illogical values would result. • Index 0: Parameter settings for output identical. • Index 1: Parameter settings for input identical. • Index 2: Parameter settings for output do not correspond to analog output type. 	—	—
A0922, No load applied to SED2	<ul style="list-style-type: none"> • No load is applied to the SED2. • Some functions may not work as under normal load conditions. 	—	—
A0923, Both JOG left and JOG right are requested	Both JOG right and JOG left have been requested. This freezes the RFG (ramp function generator) output frequency at its current value.	—	—
A0952, Belt failure detected	Load conditions at the motor indicate a belt failure or mechanical fault.	<ul style="list-style-type: none"> • No breakage, seizure, or obstruction of SED2 train. • Correct operation of external speed sensor, if in use. 	—

Replacement Parts

Replacement Part Description	Part Number
Frame Size A, Fan Assembly, 3-Wire	SED2-FAN-20A
Frame Size B, Fan Assembly, 3-Wire	SED2-FAN-20B
Frame Size C, Fan Assembly, 3-Wire	SED2-FAN-20C
DIM Module Assembly, Frame Sizes D through F	SED2-DIMMOD-DF
Frame Size D & E, Fan Assembly 1 (ADDA)	SED2-FAN-20DE1
Frame Size D & E, Fan Assembly 2 (PAPST)	SED2-FAN-20DE2
Frame Size F, Fan Assembly	SED2-FAN-20F
I/O Module MM436 (SBT) Frame Size A through F	SED2-IOBD1
Terminal Cover, Frame Size A through C	SED2-COV1-ABC
420/440 Frame Size B, Power Connections Cover	SED2-COV2-B
420/440 Frame Size C, Power Connections Cover	SED2-COV2-C
Frame Size B, Fan Assembly IP54 (SBT)	SED2-FAN-54B
Frame Size C, Fan Assembly IP54 (SBT)	SED2-FAN-54C
Frame Size D & E, Fan Assembly IP54 (SBT)	SED2-FAN-54DE
Frame Size F, Fan Assembly IP54 (SBT)	SED2-FAN-54F

Repair

Only Siemens service departments, repair centers authorized by Siemens Building Technologies, Inc., or authorized personnel who are fully acquainted with the SED2 may repair this equipment. Replace defective parts or components using original manufacturer parts.

**DANGER:**

Always disconnect the power source before opening the SED2.

Always wait 5 minutes after disconnecting the SED2 from the power source before performing any work. The DC link capacitors of all SED2s remain charged with dangerous voltages for 5 minutes after all supplies have been disconnected. When working on open equipment, note that live parts are exposed. Do not touch these parts.

**WARNING:**

Only use this equipment for the purpose specified by the manufacturer. Unauthorized modifications and the use of spare parts and accessories that are not sold or recommended by the manufacturer of the equipment can cause fires, electric shocks, and injuries.

Technical Specifications

Table 9. Drive Specifications.

Drive Specifications	Description
Input voltage and power (3 phase)	200V to 240V, 3AC±10%. 1/2 hp to 60 hp
	380V to 480V, 3AC ±10% 1/2 hp to 125 hp
	500V to 600V, 3 AC ±10% 1 hp to 125 hp
Input frequency	47 Hz to 63 Hz
Output frequency	0 Hz to 150 Hz
Power factor	≥0.9
VFD degree of efficiency	96% to 97%
Switch-on current	Less than nominal input current
Auxiliary supply 24V	Galvanically separated, unregulated auxiliary supply (18V to 32V) 100 mA
Overload capacity	100% for 60 seconds, 150% for 3 seconds
Control method	Linear, parabolic and programmable V/f; and flux current control low-power mode
PWM frequency	2k Hz to 16k Hz (adjustable in 2k Hz increments)
Fixed frequencies	15 programmable
Skip frequency bands	4 programmable
Setpoint resolution	0.01 Hz digital
	0.01 Hz serial
	10 bit analog
Digital inputs (sink/source)	6: fully programmable and scalable isolated digital inputs, switchable
Analog inputs	2: 0 Vdc to 10 Vdc, 0/4 mA to 20 mA, can also be configured as digital inputs or Ni 1000 input
Relay outputs	2: configurable 30 Vdc /5A (resistive), 250 Vac 2A (inductive)
Analog outputs	2: programmable (0/4 mA to 20 mA)
Serial interface	RS-485; Protocols: USS, P1 and N2; Transmission rate: Up to 38.4k Baud
Protection level	IP20
	NEMA Type 1 with protective shield and gland plate installed
	NEMA Type 12/IP54
Temperature ranges	Operating: 14°F to 104°F (–10°C to 40°C)
	Storage: –40°F to 158°F (–40°C to 70°C)
Humidity	95% rh, non-condensing
Operational altitudes	Up to 3280 ft (1000m) above sea level without derating

Drive Specifications	Description
Protection features	<ul style="list-style-type: none"> • Under-voltage • Over-voltage • Overload • Ground fault • Short circuit • Stall prevention • Locked motor • Motor overtemperature $I^2 t$, PTC • Over-temperature • Parameter PIN protection
Standards	UL, cUL, CE, C-tick
CE conformity	Conformity with EC Low Voltage Directive 73/23/EEC

Appendix A: Parameters, Defaults, and Settings

Parameter	Description	Unit	User Setting	Min	Default	Max	Access Level
r0000	Drive display (defined in P0005)	—		—	—	—	All
r0002	Drive state (actual)	—		—	—	—	3
P0003	User access level	—		0	1	4	1
P0004	Parameter filter	—		0	0	22	1
P0005	Display selection for r0000	—		2	21	2294	2
P0006	Display mode for r0000	—		0	2	4	3
P0010	Commissioning parameter filter	—		0	0	30	1
P0011	Lock for user-defined parameter	—		0	0	65535	3
P0012	Key for user-defined parameter	—		0	0	65535	3
P0013	User-defined parameter	—		0	0	65535	3
r0018	Firmware version	—		—	—	—	3
r0019	CO/BO: BOP control word	—		—	—	—	3
r0020	CO: Actual frequency setpoint	Hz		—	—	—	3
r0021	CO: Actual frequency	Hz		—	—	—	3
r0022	Actual Rotor speed	1/min		—	—	—	3
r0024	CO: Actual output frequency	Hz		—	—	—	3
r0025	CO: Actual output voltage	V		—	—	—	3
r0026	CO: Actual DC link output voltage	V		—	—	—	3
r0027	CO: Actual output current	A		—	—	—	3
r0031	Actual torque	Nm		—	—	—	3
r0032	Actual power	—		—	—	—	3
r0035	CO: Actual Motor temperature	°C		—	—	—	3
r0039	CO: Energy consumption meter	kWh		—	—	—	3

Parameter	Description	Unit	User Setting	Min	Default	Max	Access Level
P0040	Reset energy consumption meter	—		0	0	1	3
r0050	CO: Active command data set	—		—	—	—	3
r0052	CO/BO: Actual status word 1	—		—	—	—	3
r0053	CO/BO: Actual status word 2	—		—	—	—	3
r0054	CO/BO: Actual control word 1	—		—	—	—	3
r0055	CO/BO: Additional actual control word	—		—	—	—	3
r0056	CO/BO: Status of motor control	—		—	—	—	3
r0061	Actual rotor speed	—		—	—	—	3
r0086	CO: Actual active current	A		—	—	—	3
P0100	Europe/North America power settings [kW or hp]	—		0	0	2	1
r0200	Actual power stack code number	—		—	—	—	3
r0206	Rated inverter power [kW]/[hp]	—		—	—	—	3
r0207	Rated inverter current	A		—	—	—	3
r0208	Rated inverter voltage	V		—	—	—	3
r0209	Maximum inverter current	A		—	—	—	3
P0304	Rated motor voltage	V		10	Varies	2000	1
P0305	Rated motor current	A		0.01	Varies	10000.00	1
P0307	Rated motor power	—		0.01	Varies	2000.00	1
P0308	Rated motor cosPhi	—		0.000	0.000	1.000	3
P0309	Rated motor efficiency	%		0.0	Varies	99.9	3
P0310	Rated motor frequency	Hz		12.00	50.00 or 60.00	650.00	1
P0311	Rated motor speed	1/min		0	Varies	40000	1
r0313	Motor pole pairs	—		—	—	—	3
P0340	Calculation of motor parameters	—		0	0	4	3
P0350	Stator resistance (line-to-line)	ohm		0.00001	Varies	2000.0	3
r0395	CO: Total stator resistance [%]	%		—	—	—	3
P0400	Select encoder type	—		0	0	12	3

Parameter	Description	Unit	User Setting	Min	Default	Max	Access Level
P0409	Pulses per second at Rated Frequency	—		1	25	500	3
P0501	Type of sensor	—		0	0	29	2
P0506	Parameter list	—		0	—	4000	3
P0507	Scalar values	—		0	1.0	9999.9	3
P0508	Unit	—		0	0	65535	3
P0509	String	—		0	0	65535	3
P0601	Motor temp. sensor	—		0	0	2	3
P0610	Motor I ² t temperature reaction	—		0	2	2	3
P0640	Motor overload factor [%]	%		10.0	110.0	400.0	3
P0700	Selection of command source	—		0	[0] 2, [1] 1	6	1
P0701	Function of digital input 1	—		0	[0] 1, [1] 0	99	2
P0702	Function of digital input 2	—		0	[0] 12, [1] 0	99	2
P0703	Function of digital input 3	—		0	9	99	2
P0704	Function of digital input 4	—		0	15	99	2
P0705	Function of digital input 5	—		0	15	99	2
P0706	Function of digital input 6	—		0	15	99	2
P0707	Function of digital input 7	—		0	0	99	3
P0708	Function of digital input 8	—		0	0	99	3
P0718	CO/BO: Hand/Auto	—		0	0	1	3
r0722	CO/BO: Binary input values	—		-	-	-	3
P0725	PNP/NPN digital inputs	—		0	1	1	3
P0731	BI: Function of digital output 1	—		0:0	52:3	4000:0	2
P0732	BI: Function of digital output 2	—		0:0	52:2	4000:0	2
r0747	CO/BO: State of digital outputs	—		—	—	—	3
P0748	Invert digital outputs	—		0	0	7	3
r0752	Actual input of ADC (analog input) [V] or [mA]	—		—	—	—	2
P0753	Smooth time ADC (analog input)	ms		0	100	10000	3

Parameter	Description	Unit	User Setting	Min	Default	Max	Access Level
r0754	Actual ADC (analog input) value after scaling [%]	%		—	—	—	2
r0755	CO: Actual ADC (analog input) after scaling [4000h]	—		—	—	—	3
P0756	Type of ADC (analog input)	—		0	0	5	2
P0757	Value x1 of ADC (analog input) scaling [V/mA]	—		-50.0	0	150.0	2
P0758	Value y1 of ADC (analog input) scaling	%		-99999.9	0.0	99999.9	2
P0759	Value x2 of ADC (analog input) scaling [V/mA]	—		-50.0	10.0	150.0	2
P0760	Value y2 of ADC (analog input) scaling	%		-99999.9	100.0	99999.9	2
P0761	Width of ADC (analog input) deadband [V/mA]	—		0	0	150.0	3
P0771	CI: DAC (analog output)	—		0:0	21:0	4000:0	2
P0773	Smooth time DAC (analog output)	ms		0	100	1000	3
r0774	Actual DAC (analog output) value [V] or [mA]	—		—	—	—	3
P0776	Type of DAC (analog output)	—		0	1	1	3
P0777	Value x1 of DAC (analog output) scaling	%		-99999.0	0.0	99999.0	2
P0778	Value y1 of DAC (analog output) scaling	—		0	0	20	2
P0779	Value x2 of DAC (analog output) scaling	%		-99999.0	100.0	99999.0	2
P0780	Value y2 of DAC (analog output) scaling	—		0	10	20	2
P0781	Width of DAC (analog output) deadband	—		0	0	20	3
P0809	Copy CDS (command data set)	—		0	0	2	3
P0810	BI: CDS (command data set) bit 0 (Local/Remote)	—		0:0	718:0	4095:0	3
P0918	CB (communications board or module) address	—		0	3	65535	3
P0927	Parameter changeable via	—		0	—	15	3

Parameter	Description	Unit	User Setting	Min	Default	Max	Access Level
r0947	Last fault code	—		—	—	—	3
r0948	Fault time	—		—	—	—	3
r0949	Fault value	—		—	—	—	3
P0952	Total number of faults	—		0	0	8	3
r0967	Control word 1	—		—	—	—	3
r0968	Status word 1	—		—	—	—	3
P0970	Factory reset	—		0	0	1	1
P0971	Transfer data from RAM to EEPROM	—		0	0	1	3
P1000	Selection of frequency setpoint	—		0	2	77	1
P1001	Fixed frequency 1	Hz		-650.0	0.00	650.00	3
P1002	Fixed frequency 2	Hz		-650.0	5.00	650.00	3
P1003	Fixed frequency 3	Hz		-650.0	10.00	650.00	3
P1004	Fixed frequency 4	Hz		-650.0	15.00	650.00	3
P1005	Fixed frequency 5	Hz		-650.0	20.00	650.00	3
P1006	Fixed frequency 6	Hz		-650.0	25.00	650.00	3
P1007	Fixed frequency 7	Hz		-650.0	30.00	650.00	3
P1008	Fixed frequency 8	Hz		-650.0	35.00	650.00	3
P1009	Fixed frequency 9	Hz		-650.0	40.00	650.00	3
P1010	Fixed frequency 10	Hz		-650.0	45.00	650.00	3
P1011	Fixed frequency 11	Hz		-650.0	50.00	650.00	3
P1012	Fixed frequency 12	Hz		-650.0	55.00	650.00	3
P1013	Fixed frequency 13	Hz		-650.0	60.00	650.00	3
P1014	Fixed frequency 14	Hz		-650.0	65.00	650.00	3
P1015	Fixed frequency 15	Hz		-650.0	65.00	650.00	3
P1016	Fixed frequency mode-Bit 0	—		1	1	3	3
P1017	Fixed frequency mode-Bit 1	—		1	1	3	3
P1018	Fixed frequency mode-Bit 2	—		1	1	3	3
P1019	Fixed frequency mode-Bit 3	—		1	1	3	3
P1020	BI: Fixed frequency selection Bit 0	—		0:0	0:0	4000:0	3

Parameter	Description	Unit	User Setting	Min	Default	Max	Access Level
P1021	Bl: Fixed frequency selection Bit 1	—		0:0	0:0	4000:0	3
P1022	Bl: Fixed frequency selection Bit 2	—		0:0	0:0	4000:0	3
P1023	Bl: Fixed frequency selection Bit 3	—		0:0	722:3	4000:0	3
r1024	CO: Act. fixed frequency	Hz		—	—	—	3
P1025	Fixed frequency mode – Bit 4	—		1	1	3	3
P1026	Bl: Fixed frequency selection Bit 4	—		0:0	722:4	4000:0	3
P1027	Fixed frequency mode – Bit 5	—		1	1	3	3
P1028	Bl: Fixed frequency selection Bit 5	—		0:0	722:5	4000:0	3
P1031	Setpoint memory of the motor potentiometer	—		0	1	1	3
P1032	Inhibit reverse direction of motor potentiometer	—		0	1	1	3
P1040	Setpoint of the motor potentiometer	Hz		-650.00	10.00	650.00	2
r1050	CO: Act. Output frequency of the motor potentiometer	Hz		—	—	—	3
r1078	CO: Total frequency setpoint	Hz		—	—	—	3
P1080	Minimum frequency	Hz		0.00	10.00	650.00	1
P1082	Maximum frequency	Hz		0.00	50.00/ 60.00 Varies	150.00	1
P1091	Skip frequency 1	Hz		0.00	0.00	650.00	3
P1092	Skip frequency 2	Hz		0.00	0.00	650.00	3
P1093	Skip frequency 3	Hz		0.00	0.00	650.00	3
P1094	Skip frequency 4	Hz		0.00	0.00	650.00	3
P1101	Skip frequency bandwidth	Hz		0.00	2.00	10.00	3
P1110	Bl: Inhibit neg. frequency Setpoint	—		0:0	1	4000:0	3
P1120	Ramp-up time	s		0.00	10.00	650.00	1
P1121	Ramp-down time	s		0.00	30.00	650.00	1

Parameter	Description	Unit	User Setting	Min	Default	Max	Access Level
P1135	OFF3 ramp-down time	s		0.00	5.00	650.00	3
P1140	BI: RFG (ramp function generator) enable	—		0:0	1:0	4000:0	3
P1141	RFG (ramp function generator) start	—		0.00	1.0	4000.0	3
P1142	RFG (ramp function generator) enable setpoint	—		0.00	1.0	4000.0	3
P1200	Flying start	—		0	0	6	3
P1202	Motor-current: flying start	%		10	100	200	3
P1203	Search rate: flying start	%		10	100	200	3
P1210	Automatic restart	—		0	1	5	3
P1211	Number of restart attempts	—		0	3	10	3
P1212	Time to first restart	s		0	30	1000	3
P1213	Restart time increment	s		0	30	1000	3
P1230	BI: Enable DC braking	—		0:0	0:0	4000:0	3
P1232	DC braking current	%		0	100	250	3
P1233	Duration of DC braking	s		0	0	250	3
P1236	Compound braking current	%		0	0	250	3
P1240	Configuration of Vdc controller	—		0	1	3	3
P1270	BI: Enable essential service	—		0:0	0:0	4000:0	3
P1300	Control mode	—		0	2	23	3
P1310	Continuous boost	%		0.0	50.0	250.0	3
P1311	Acceleration boost	%		0.0	0.0	250.0	3
P1312	Starting boost	%		0.0	0.0	250.0	3
P1335	Slip compensation	%		0.0	0.0	600.0	3
P1336	Slip limit	%		0	250	600	3
r1337	CO: V/f slip frequency	%		-	-	-	3
P1800	Pulse frequency	kHz		2	Varies	16	2
r1801	CO: Actual switching frequency	kHz		—	—	—	3
P1820	Reverse output phase sequence	—		0	0	1	3
P1910	Select motor data identification	—		0	0	20	3

Parameter	Description	Unit	User Setting	Min	Default	Max	Access Level
r1912	Identified stator resistance	ohm		—	—	—	3
P2000	Reference frequency	Hz		1.00	50/60	650.00	2
P2001	Reference voltage	V		10	1000	2000	3
P2002	Reference current	A		0.10	Varies	10000.00	3
P2004	Reference power	—		—	—	—	3
P2009	USS normalization	—		0	0	1	3
P2010	USS baud rate	—		4	6	12	3
P2011	USS address	—		0	0	31	3
P2014	USS telegram off time	ms		0	0	65535	3
P2040	CB telegram off time	ms		0	20	65535	3
P2041	CB parameter	—		0	0	65535	3
r2050	PZD from CB	—		—	—	—	3
P2051	PZD to CB	—		0:0	52:0	4000:0	3
r2053	CB identification	—		—	—	—	3
r2054	CB diagnosis	—		—	—	—	3
P2100	Alarm number selection	—		0	0	65535	3
P2101	Stop reaction value	—		0	0	5	3
r2110	Warning number	—		—	—	—	3
P2111	Total number of warnings	—		0	0	4	3
r2114	Run time counter	—		—	—	—	3
P2115	AOP real time clock	—		0	0	65535	3
P2155	Threshold frequency f_1	Hz		0.00	30.00	650.00	3
P2156	Delay time of threshold frequency f_1	ms		0	10	10000	3
P2167	Switch-off frequency f_off	Hz		0.00	1.00	10.00	3
P2168	Delay time T_off	ms		0	10	10000	3
P2181	Belt failure detection mode	—		0	0	6	3
P2182	Belt threshold frequency 1	Hz		0.00	5.00	650.00	3
P2183	Belt threshold frequency 2	Hz		0.00	30.00	650.00	3
P2184	Belt threshold frequency 3	Hz		0.00	50.00	650.00	2
P2185	Upper torque threshold 1	Nm		0.0	99999.0	99999.0	3

Parameter	Description	Unit	User Setting	Min	Default	Max	Access Level
P2186	Lower torque threshold 1	Nm		0.0	0.0	99999.0	3
P2187	Upper torque threshold 2	Nm		0.0	99999.0	99999.0	3
P2188	Lower torque threshold 2	Nm		0.0	0.0	99999.0	3
P2189	Upper torque threshold 3	Nm		0.0	99999.0	99999.0	3
P2190	Lower torque threshold 3	Nm		0.0	0.0	99999.0	3
P2191	Belt failure speed tolerance	Hz		0.00	3.00	20.00	3
P2192	Time delay for belt failure	s		0	10	65	3
r2197	CO/BO: Monitoring word 1	—		—	—	—	3
r2198	CO/BO: Monitoring word 2	—		—	—	—	3
P2200	BI: Enable PID controller	—		0:0	0:0	4000:0	3
P2201	Fixed PID setpoint 1	%		-200.00	0.00	200.00	3
P2202	Fixed PID setpoint 2	%		-200.00	10.00	200.00	3
P2203	Fixed PID setpoint 3	%		-200.00	20.00	200.00	3
P2204	Fixed PID setpoint 4	%		-200.00	30.00	200.00	3
P2205	Fixed PID setpoint 5	%		-200.00	40.00	200.00	3
P2206	Fixed PID setpoint 6	%		-200.00	50.00	200.00	3
P2207	Fixed PID setpoint 7	%		-200.00	60.00	200.00	3
P2208	Fixed PID setpoint 8	%		-200.00	70.00	200.00	3
P2209	Fixed PID setpoint 9	%		-200.00	80.00	200.00	3
P2210	Fixed PID setpoint 10	%		-200.00	90.00	200.00	3
P2211	Fixed PID setpoint 11	%		-200.00	100.00	200.00	3
P2212	Fixed PID setpoint 12	%		-200.00	110.00	200.00	3
P2213	Fixed PID setpoint 13	%		-200.00	120.00	200.00	3
P2214	Fixed PID setpoint 14	%		-200.00	130.00	200.00	3
P2215	Fixed PID setpoint 15	%		-200.00	130.00	200.00	3
P2216	Fixed PID setpoint mode-Bit 0	—		1	1	3	3
P2217	Fixed PID setpoint mode-Bit 1	—		1	1	3	3
P2218	Fixed PID setpoint mode-Bit 2	—		1	1	3	3
P2219	Fixed PID setpoint mode-Bit 3	—		1	1	3	3
P2220	BI: Fixed PID setpoint select Bit 0	—		0:0	0:0	4000:0	3

Parameter	Description	Unit	User Setting	Min	Default	Max	Access Level
P2221	BI: Fixed PID setpoint select Bit 1	—		0:0	0:0	4000:0	3
P2222	BI: Fixed PID setpoint select Bit 2	—		0:0	0:0	4000:0	3
P2223	BI: Fixed PID setpoint select Bit 3	—		0:0	722:3	4000:0	3
r2224	CO: Act. fixed PID setpoint	%		—	—	—	3
P2225	Fixed PID setpoint mode-Bit 4	—		1	1	2	3
P2226	BI: Fixed PID setpoint select Bit 4	—		0:0	722:4	4000:0	3
P2227	Fixed PID setpoint mode-Bit 5	—		1	1	2	3
P2228	BI: Fixed PID setpoint select Bit 5	—		0:0	722:5	4000:0	3
P2231	Setpoint memory of PID-motor potentiometer	—		0	1	1	3
P2232	Inhibit rev. direct. of PID-motor potentiometer	—		0	1	1	3
P2240	Setpoint of PID-motor potentiometer	%		-200.00	10.00	200.00	3
r2250	CO: Output setpoint of PID-motor potentiometer	%		—	—	—	3
P2253	CI: PID setpoint	—		0:0	2250:0	4000:0	2
P2254	CI: PID trim	—		0:0	0:0	4000:0	3
P2261	PID setpoint filter	—		0.00	0.00	60.00	3
r2262	CO: Act. PID filtered setpoint	%		—	—	—	3
P2264	CI: PID feedback	—		0:0	755:1	4000:0	2
P2265	PID feedback filter time constant	s		0.00	0.00	60.00	3
P2267	Max. value for PID feedback	%		-200.00	150.00	200.00	3
P2268	Min. value for PID feedback	%		-200.00	-50.00	200.00	3
P2269	Gain applied to PID feedback	—		0.00	100.00	500.00	3
P2270	PID feedback function selector	—		0	0	3	3
P2271	PID transducer type	—		0	0	1	3
r2272	CO: PID scaled feedback	%		—	—	—	3
r2273	CO: PID error	%		—	—	—	3

Parameter	Description	Unit	User Setting	Min	Default	Max	Access Level
P2274	PID derivative time	s		0	0	65535	2
P2279	PID neutral zone	%		0.00	0.00	100.00	3
P2280	PID proportional gain	—		0.000	1.200	65.000	2
P2285	PID integral time	s		0	30	65535	2
P2291	PID output upper limit	%		0.00	100.00	100.00	2
P2292	PID output lower limit	%		-200.00	0.00	200.00	2
P2293	PID limit ramp time	s		0.00	0.00	100.00	3
r2294	CO: Actual PID output	%		—	—	—	3
P2303	PID output offset	—		0.0	0.0	4000.0	2
P2304	PID opening time	—		0	0	65535	2
P2305	PID closing time	—		0	0	65535	2
P2306	PID actuator direction	—		0	1	1	2
P2370	Selection of motor staging stop mode	—		0	0	1	3
P2371	Selection of external motor configuration	—		0	0	8	3
P2372	Enable motor cycling	—		0	0	1	3
P2373	Motor staging hysteresis	%		0.0	20.0	200.0	3
P2374	Motor staging delay	s		0	30	650	3
P2375	Motor de-staging delay	s		0	30	650	3
P2376	Delay override	%		0.0	25.0	200.0	3
P2377	Delay override lockout timer	s		0	30	650	3
P2378	Staging frequency f, %fMax	%		0.0	50.0	120.0	3
r2379	CO/BO: Status of motor staging	—		—	—	—	3
P2380	Motor hours run	h		0	0	100000	3
P2390	Hibernation setpoint	%		-200.00	0.00	200.00	3
P2391	Hibernation timer	s		0	0	254	3
P2392	Restart PID error	%		-200.00	0.00	200.00	3
P3900	End of quick commissioning	—		0	0	3	1

Appendix B: SED2 Point Maps

Table 10. SBT P1 Point Cross Reference to SED2.

Point No.	Point Type	Descriptor	Factory Default (SI Units)	Eng. Units (SI Units)	On Text	Off Text	SED2 Reference
01	LAO	CTLR ADDRESS	99	–	–	–	SBT
02	LAO	APPLICATION	2722	–	–	–	SBT
03	LAI	FREQ OUTPUT	0	HZ	–	–	r0021
05	LAI	SPEED	0	RPM	–	–	Calculated based on P0311
06	LAI	CURRENT	0	A	–	–	r0027
07	LAI	TORQUE	0	NM	–	–	r0031
08	LAI	ACTUAL POWER	0	HP/ KW	–	–	r0032
09	LAI	TOTAL KWH	0	KWH	–	–	r0039
13	LAI	DC BUS VOLT	0	V	–	–	r0026
14	LAI	REFERENCE	0	HZ	–	–	r0020
16	LAI	RATED PWR	0	HP/ KW	–	–	P0307
17	LAI	OUTPUT VOLTS	0	V	–	–	r0025
20	LAO	OVRD TIME	1	HRS	–	–	
21	LDI	FWD.REV	FWD	–	REV	FWD	r0054 bit 11
22	LDO	CMD FWD.REV	FWD	–	REV	FWD	P0842(2)
23	LDI	STOP.RUN	STOP	–	RUN	STOP	r0019 bit 1
24	LDO	CMD STP.STRT	STOP	–	START	STOP	P0840(2)
25	LDI	AT MAX FREQ	NO	–	MAX	NO	
26	LDI	CONTROL MODE	SERIAL	–	SERIAL	LOCAL	P0700(2)
27	LDI	ENABLED	OFF	–	ENABLED	OFF	r0052 bit 0
28	LDI	READY TO RUN	OFF	–	READY	OFF	r0052 bit 1

Table 10. SBT P1 Point Cross Reference to SED2.

Point No.	Point Type	Descriptor	Factory Default (SI Units)	Eng. Units (SI Units)	On Text	Off Text	SED2 Reference
29	LDO	DAY.NIGHT	DAY	–	NIGHT	DAY	SBT
30	LAO	CURRENT LIM	1400	PCT	–	–	r0067
31	LAO	ACCEL TIME 1	500	SEC	–	–	read P1120
32	LAO	DECEL TIME 1	500	SEC	–	–	read P1121
34	LDO	SEL HND.AUTO (reference)	AUTO	–	AUTO	HAND	P1000(2)
35	LDO	RUN ENABLE	ENABLE	–	ENABLE	OFF	r0052 bit 0
40	LDO	DIGITAL OUT 1	OFF	–	ON	OFF	P0731(2) read at r0747
41	LDO	DIGITAL OUT 2	OFF	–	ON	OFF	P0732(2) read at r0747
45	LAI	ANALOG IN 1	0	PCT	–	–	r0754(0)
46	LAI	ANALOG IN 2	0	PCT	–	–	r0754(1)
47	LAI	ANALOG OUT 1	0	PCT	–	–	–
48	LAI	ANALOG OUT 2	0	PCT	–	–	–
51	LAO	FREQ REF	0	PCT	–	–	r0754(0)
52	LAI	FREQ ACTUAL	0	PCT	–	–	r0754(0)
53	LAO	FREQ MAX	2450	HZ	–	–	P1082
55	LAO	PID SETP REF	8602	PCT	–	–	r0754(0)
56	LAI	PID SETP OUT	0	PCT	–	–	r2294
57	LAO	PID UP LMT	12288	PCT	–	–	P2291
58	LAO	PID LO LMT	8192	PCT	–	–	P2292
59	LAI	PID OUTPUT	0	PCT	–	–	r2294
60	LAI	PI FEEDBACK	0	PCT	–	–	r2272
61	LAI	P GAIN	0	PCT	–	–	P2280
62	LAI	I GAIN	0	PCT	–	–	P2285
63	LAI	D GAIN	0	PCT	–	–	P2274
64	LDO	ENABLE PID	0		ON	OFF	P2200
66	LAI	FEEDBK GAIN	0	PCT	–	–	P2269

Table 10. SBT P1 Point Cross Reference to SED2.

Point No.	Point Type	Descriptor	Factory Default (SI Units)	Eng. Units (SI Units)	On Text	Off Text	SED2 Reference
68	LAI	LOW PASS	0	–	–	–	–
71	LDI	DIGITAL IN 1	0	–	ON	OFF	r0722 bit 0
72	LDI	DIGITAL IN 2	0	–	ON	OFF	r0722 bit 1
73	LDI	DIGITAL IN 3	0	–	ON	OFF	r0722 bit 2
74	LDI	DIGITAL IN 4	0	–	ON	OFF	r0722 bit 3
75	LDI	DIGITAL IN 5	0	–	ON	OFF	r0722 bit 4
76	LDI	DIGITAL IN 6	0	–	ON	OFF	r0722 bit 5
80	LAO	WDOG TIME	0	–	–	–	–
83	LAI	INVERTER VER	0	–	–	–	r0018
84	LAI	DRIVE MODEL	0	–	–	–	–
90	LAI	LAST FAULT	0	–	–	–	r0947(0)
91	LAI	1st FAULT	0	–	–	–	r0947(1)
92	LAI	2nd FAULT	0	–	–	–	r0947(2)
93	LAI	3rd FAULT	0	–	–	–	r0947(3)
94	LDI	OK FAULT	0	–	FAULT	OK	r0052 bit 3
95	LDO	FAULT ACK	0	–	ON	OFF	r0054 bit 7
96	LDI	WARNING	0	–	WARN	OK	r0052 bit 7
97	LAI	LAST WARNING	0	–	–	–	r2110 (0)
99	LAO	ERROR STATUS	0	–	–	–	–

Table 11. JCI N2 Point Cross Reference to SED2.

Point Number	Name	Default Value	Units	Notes	On Text	Off Text	SED2 Ref.
					Or Range		
A11	FREQ OUTPUT	0	HZ	No Override	-650.00 to 650.00		r0024
A12	SPEED	0	RPM	No Override	-16250 to 16250		r0022
A13	CURRENT	0	A	No Override	0 to 1638.35		r0027
A14	TORQUE	0	NM	No Override	-3250.0 to 3250.0		r0031
A15	DC BUS VOLTS	0	V	No Override	0 to 32767		r0026
A16	REFERENCE	0	HZ	No Override	-650.00 to 650.00		r0020
A17	OUTPUT VOLTS	0	V	No Override	0 to 32767		r0025
A18	ANALOG IN 1	0	PCT	No Override	-300.0 to 300.0		r0754/0
A19	ANALOG IN 2	0	PCT	No Override	-300.0 to 300.0		r0754/1
A110	PI FEEDBACK	0	PCT	No Override	-100.0 to 100.0		r2266
A111	ANALOG OUT 1	0	PCT	No Override	-100.0 to 100.0		r0774/0
A112	ANALOG OUT 2	0	PCT	No Override	-100.0 to 100.0		r0774/1
A113	PID SETP OUT	0	PCT	No Override	-100.0 to 100.0		r2250
A114	PID OUTPUT	0	PCT	No Override	-100.0 to 100.0		r2294
A115	ACTUAL PWR	0	KW	No Override	0 to 327.67		r0032
A116	TOTAL KWH	0	KWH	No Override	0 to 32767		r0039
A117	FREQ ACTUAL	0	PCT	No Override	-100.00 to 100.00		HIW
AO1	FREQ REF	0	PCT	–	0.00 to 100.00		HSW
B11	ENABLED	0	–	No Override	ON	OFF	ZSW:0
B12	READY TO RUN	0	–	No Override	READY	OFF	ZSW:1
B13	STOP RUN	0	–	No Override	RUN	STOP	ZSW:2
B14	AT MAX FREQ	0	–	No Override	MAX	NO	ZSW:10
B15	CONTROL MODE	1	–	No Override	SERIAL	LOCAL	ZSW:9
B16	FAULT	0	–	No Override	FAULT	OK	ZSW:3
B17	WARNING	0	–	No Override	WARN	OK	ZSW:7
B18	DIGITAL IN 1	0	–	No Override	ON	OFF	r0722:0
B19	DIGITAL IN 2	0	–	No Override	ON	OFF	r0722:1

Table 11. JCI N2 Point Cross Reference to SED2.

Point Number	Name	Default Value	Units	Notes	On Text	Off Text	SED2 Ref.
					Or Range		
BI10	DIGITAL IN 3	0	–	No Override	ON	OFF	r0722:2
BI11	DIGITAL IN 4	0	–	No Override	ON	OFF	r0722:3
BI12	DIGITAL IN 5	0	–	No Override	ON	OFF	r0722:4
BI13	DIGITAL IN 6	0	–	No Override	ON	OFF	r0722:5
BI14	FWD REV	0	–	No Override	FWD	REV	ZSW:14
BO1	CMD START	0	–	–	START	STOP	STW:0
BO2	RUN ENABLE	1	–	–	ENABLE	OFF	STW:3
BO3	FAULT ACK	0	–	–	ON	OFF	STW:7
BO4	HAND AUTO	0	–	–	HAND	AUTO	P0718
BO5	DIGITAL OUT 1	0	–	–	ON	OFF	P0731
BO6	DIGITAL OUT 2	0	–	–	ON	OFF	P0733
BO7	CMD FWD REV	0	–	–	REV	FWD	STW:11
BO8	ENABLE PID	0	–	–	ON	OFF	P2200
ADF1	ACCEL TIME 1	10.00	SEC	–	0.00 to 650.00		P1120
ADF2	DECEL TIME 1	10.00	SEC	–	0.00 to 650.00		P1121
ADF3	CURRENT LMT	150.0	PCT	–	10.0 to 400.0		P0640
ADF4	P GAIN	3.000	–	–	0.000 to 65.000		P2280
ADF5	I GAIN	0	SEC	–	0.000 to 60.000		P2285
ADF6	D GAIN	0	–	–	0.000 to 60.000		P2274
ADF7	FEEDBK GAIN	100.00	PCT	–	0.00 to 500.00		P2269
ADF8	LOW PASS	0	–	–	0.00 to 60.00		P2265
ADF9	PID SETP REF	0	PCT	–	-200.0 to 200.0		P2240
ADF10	PID UP LMT	100.0	PCT	–	-200.0 to 200.0		P2291
ADF11	PID LO LMT	0	PCT	–	-200.0 to 200.0		P2292
ADF12	FREQ MAX	50.00	HZ	–	1.00 to 650.00		P2000
ADF13	RATED PWR	0	KW	Read Only	0 to 327.67		r0206
ADF14	INVERTER VER	0	–	Read Only	0.00 to 327.67		r0018
ADI1	WDOG TIME	0	MS	–	9999		P2040

Table 11. JCI N2 Point Cross Reference to SED2.

Point Number	Name	Default Value	Units	Notes	On Text	Off Text	SED2 Ref.
					Or Range		
ADI2	DRIVE MODEL	0	--	Read Only	0 to 32767		r0200
ADI3	LAST FAULT	0	--	Read Only	0 to 32767		r0947
ADI4	1ST FAULT	0	--	Read Only	0 to 32767		r0947
ADI5	2ND FAULT	0	--	Read Only	0 to 32767		r0947
ADI6	3RD FAULT	0	--	Read Only	0 to 32767		r0947
ADI7	LAST WARNING	0	--	Read Only	0 to 32767		r2110

Glossary

Access Level

The degree of authorization a user has when using SED2 parameters. Also see User Access Level parameter P0003.

ADC

Analog to Digital Converter; refers to analog inputs.

AOP

Advanced Operator Panel.

Boost

Applies an offset relative to the rated motor current. Boost is useful for loads with high inertia. Also see Continuous Boost parameter P1310, Acceleration Boost parameter P1311, and Starting Boost parameter P1312.

BOP

Basic Operator Panel.

CDS

Command Data Set.

Control Mode

Controls relationship between speed of motor and voltage supplied by SED2. Also see Control Mode parameter P1300.

DAC

Digital to Analog Converter; refers to analog outputs

DC Braking

Causes the motor to stop rapidly by applying a DC braking current (current applied also holds motor shaft stationary). When the DC braking signal is applied, the SED2 output pulses are blocked and the DC current is not applied until the motor has been sufficiently demagnetized. Also see Enable DC Braking parameter P1230).

EMC

Electromagnetic Compatibility.

EMI

Electromagnetic Interference.

Fixed Frequency

Frequency setpoints that are based on selection of a predetermined source.

Flying Start

Starts SED2 onto a spinning motor by rapidly changing the output frequency of the SED2 until the actual motor speed has been found. Then, the motor runs up to setpoint using the normal ramp time.

Inverter

Another term for a variable frequency drive (VFD).

IP20

IP20 is the enclosure rating for the standard SED2 from Europe; there is no equivalent North American enclosure rating. An enclosure with an IP20 rating is protected against penetration of solid objects greater than 0.47 inches (12mm) and it is protected against vertically falling drops of water such as from condensation.

Mains

Another term for input line power.

Motor I²t Temperature

Provides a model for estimating the thermal motor value; used for internal motor overload protection. Also see Motor I²t Temperature Reaction parameter P0610 and Motor temperature Sensor parameter P0601.

Motor Pole Pairs

One of the pole pairs is called a winding.

NEMA Type 1

NEMA Type 1 SED2s include gland plates (frame sizes A through C) and protection shields. An enclosure with a NEMA Type 1 rating is intended for indoor use, primarily to provide a degree of protection against contact with the enclosed equipment or for locations where unusual service conditions do not exist. NEMA Type 1 enclosures protect the operator from electric hazard and protect the equipment from falling material.

NEMA Type 12/IP54

IP54 is a European enclosure rating; there is no equivalent North American rating, although it exceeds the NEMA Type 12 rating. An enclosure with a NEMA Type 12 rating is intended for indoor use, primarily to provide a degree of protection against dust, falling dirt, and dripping non-corrosive liquids. An enclosure with an IP54 rating is protected against dust (limited ingress, no harmful deposit) and it is protected against water sprayed from all directions (limited ingress permitted).

OFF1

The OFF1 command stops the SED2 within the selected ramp-down time (P1121).

OFF2

The OFF2 command causes a free coasting of the motor to a standstill (impulses for the power section of the SED2 are disabled).

OFF3

The OFF3 command causes the motor to decelerate rapidly.

Overcurrent

A SED2 fault condition that occurs, for example, when motor power is greater than SED2 power. Also see Fault Code F0001.

Overvoltage

A SED2 fault condition that occurs, for example, when the input line power is too high or if the motor is in regenerative mode (caused by fast ramp downs or if the motor is driven from an active load). Also see Fault Code F0002.

Parameter Filter

Functional categories of parameters that are available to a user. Also see Parameter Filter P0004.

Parameter Index/Indexes

Subsets of closely related information associated with a particular parameter function.

For example, the following indexes are associated with P0700, P1000, and digital input and output parameters:

IN000 (AUTO), 1st Command Data Set (CDS)
IN001 (HAND, 2nd Command Data Set (CDS)

The following indexes are associated with analog input and output parameters:

IN000, Analog Input 1
IN001, Analog Input 2.

PID

Proportional, Integral, Derivative.

Quick Commissioning

Predefined procedure consisting of fundamental parameters to configure the SED2 for operation.

Ramp-down Time

Time for the motor to ramp down. Also see Ramp-down Time parameter P1121.

Ramp-up Time

Time for the motor to ramp up. Also see Ramp-up Time parameter P1120.

RFG

Ramp Function Generator.

RFI

Radio Frequency Interference.

Skip Frequency

Frequencies that are skipped to avoid effects of mechanical resonance. Also see Skip Frequency parameter P1091.

Slip Compensation

Dynamically adjusts the output frequency of the SED2 so that the motor speed is kept constant independent of the motor load. Also see Slip Compensation parameter P1335.

Stator Resistance

Impedance produced from each motor winding.

Train (HVAC)

Sequence or succession of mechanical equipment.

Undervoltage

A SED2 fault condition that occurs, for example, when input line power has failed or is outside the voltage reduction tolerance. Also see Fault Code F0003.

VFD/VSD

Variable Frequency Drive/Variable Speed Drive. Both terms are used for a device that controls the frequency or speed of another device such as a fan or pump motor.

Siemens Building Technologies, Inc.

1000 Deerfield Parkway
Buffalo Grove, IL 60089-4513
Tel: +1 847-215-1000
Fax +1 847-215-1093

Siemens Building Technologies, Ltd.

2 Kenview Blvd.
Brampton, Ontario
Canada L6T 5E4
Tel: +1 905-799-9937

Siemens Building Technologies AG

Gubelstrasse 22
CH-6301 Zug
Tel: +41 41 724 24 24
Fax +41 41 724 35 22

Siemens Building Technologies Ltd.

16/F, Laford Centre
838 Lai Chi Kok Road
Kowloon, Hong Kong
Tel: +852 2917 5700
Fax +852 2904 1126

www.sbt.siemens.com