

Discrete Thyristors and Diodes

SEMIKRON offers a wide range of discrete thyristors and diodes for standard and fast applications in different case designs (see table below).

Thyristors	
Metal case with threaded studs	10 ... 30 A/ ...1800 V
Capsule case	240...2400 A/ ...1700 V

Diodes	
Plastic case with axial terminals	1...3 A/ ...1700 V
Metal case with axial terminals	2...5 A/ ...1700 V
Metal case with threaded studs	20...400 A/ ...3000 V
Capsule case	240...2400 A/ ...3600 V

Fast diodes	
TO 218/220 plastic case	20...67 A/...1700 V
Metal case with threaded studs	26...168 A/ ...1500 V

This section explains products for rugged industrial applications. Further standard and fast axial lead diodes in plastic cases, as well as SMD cases can be found in our LOW POWER RECTIFIER range, which is intended in particular for consumer applications and industrial applications with relatively low requirements in terms of component ruggedness with regard to peak current, voltage and temperature values.

Features

Axial lead diodes

- Taped for automatic insertion

Threaded stud thyristors and diodes

- Hermetic metal cases with glass insulators
- International standard cases with threaded studs ISO M5...M24 x 1.5, UNF 1/4 ... 3/4 10 - 32 "

Capsule thyristors and diodes

- Hermetic metal capsule-type case with ceramic insulators in accordance with international standards
- Precious metal steel pressure contacts
- For single and double-sided cooling
- Thyristors with internal amplifying gates
- Very rugged with regard to surge current and load cycle capability

Technical Explanations

All terms in [] apply solely to thyristors; for more details, please refer to the relevant sections on thyristors, rectifier diodes and fast rectifier diodes.

Non-repetitive peak reverse voltage V_{RSM} ; [non-repetitive peak off-state voltage V_{DSM}]

Maximum permissible value for non-repetitive, occasionally transient peak voltages.

Repetitive peak reverse and off-state voltages [V_{DRM}] and V_{RRM}

Maximum permissible value for repetitive transient off-state and reverse voltages.

Direct reverse voltages V_R for continuous duty

Maximum permissible direct reverse voltage for stationary operation for diodes (V_R) [or thyristors (V_D , V_R)]. This value is $0.7 V_{RRM}$ [$0.7 V_{DRM}$].

Mean forward [on-state] current I_{FAV} , [I_{TAV}]

The symbols I_{FAV} , [I_{TAV}] are used to refer to both the mean current values in general and the current limits. The limiting values are absolute maximum continuous values for the on-state current load of a diode [thyristor] for a given current waveform and given cooling conditions (e.g. case temperature T_c). At this current value, the maximum permissible junction temperature is reached, with no margins for overload or worst-case reserves. The recommended maximum continuous current is therefore approximately $0.8 I_{FAV}$ [I_{TAV}]. For operation frequencies between 40 Hz and 200 Hz the maximum mean on-state current can be taken from Fig. 1 of the datasheet. If standard diodes and thyristors (diodes/thyristors for line application) are operated at frequencies between 200 Hz and 500 Hz, further current reductions should be carried out to compensate the switching losses that are no longer negligible.

RMS forward [on-state] current I_{FRMS} , [I_{TRMS}]

The symbols I_{FRMS} [I_{TRMS}] are used to refer to both the mean current values and the current limits. The limiting values are absolute maximum values for the continuous on-state current for any chosen current waveform and cooling conditions.

Surge forward [on-state] current I_{FSM} [I_{TSM}]

Crest value for a surge current in the form of a single sinusoidal half wave which lasts for 10 ms. After occasional current surges with current values up to the given surge forward current, the diode [thyristor] can withstand the reverse voltages stated in Fig. 7 [Fig. 8] of the datasheets.

Surge current characteristics $I_{F(OV)}$, [$I_{T(OV)}$]

Crest values for full or part sinusoidal half wave currents lasting between 1 ms and 10 ms or for sequential sinusoidal half wave currents with a maximum duration of 10 ms,

permissible under fault conditions only, i.e. the diode [thyristor] may only be subjected to this value occasionally; the controllability of a thyristor may be lost during overload (Fig. 7, [8]). The overload current depends on the off-state voltage value across the component.

i²t value

This value is given to assist in the selection of suitable fuses to provide protection against damage caused by short circuits and is given for junction temperatures of 25 °C and 125 °C. The i²t value of the fuse for the intended input voltage and the prospective short circuit in the device must be lower than the i²t value of the diode [thyristor] for t = 10 ms. As the i²t value of the fuse falls more rapidly as the operating temperature increases than the i²t value of the diode [thyristor], a comparison between the i²t value of the diode [thyristor] for 25 °C and the i²t value of the (unloaded) fuse is generally sufficient.

Direct reverse [off-state] current I_{RD} [I_{DD}]

Maximum reverse or off-state [for thyristors] current value for the given temperature and maximum voltage. This value depends exponentially on the temperature.

Direct forward [on-state] voltage V_F [V_T]

Maximum forward voltage across the main terminals for a given current at 25 °C.

Threshold voltage V_(TO) [V_{T(TO)}] and forward [on-state] slope resistance r_T

These two values define the forward characteristics (upper value limit) and are used to calculate the instantaneous value of the forward power dissipation P_F [P_T] or the mean forward power dissipation P_{FAV} [P_{TAV}]:

$$P_{F[T]} = V_{T(TO)} \cdot I_{F[T]} + r_T \cdot I_{F[T]}^2$$

$$P_{F[T]AV} = V_{T(TO)} \cdot I_{F[T]AV} + r_T \cdot I_{F[T]RMS}^2$$

$$I_{F[T]RMS}^2 / I_{F[T]AV}^2 = 360^\circ / \Theta$$

for square-wave pulses

$$I_{F[T]RMS}^2 / I_{F[T]AV}^2 = 2.5 \text{ or}$$

$$I_{F[T]RMS}^2 / I_{F[T]AV}^2 = (\pi/2)^2 \cdot 180^\circ / \Theta$$

for [part] sinusoidal half waves

Θ: current flow angle

i_{F[T]}: Instantaneous forward current value

I_{F[T]RMS}: RMS forward [on-state] current

I_{F[T]AV}: Mean forward [on-state] current

Recovery charge Q_{rr}

Q_{rr} is the total charge which flows through the main circuit (current-time area) during commutation over the reverse recovery time t_{rr}. The corresponding characteristic in the datasheet shows this value's dependence on the peak forward current I_{FM} [I_{TM}] before commutation, as well as the forward current rate of fall di/dt (cf. Fig. 1).

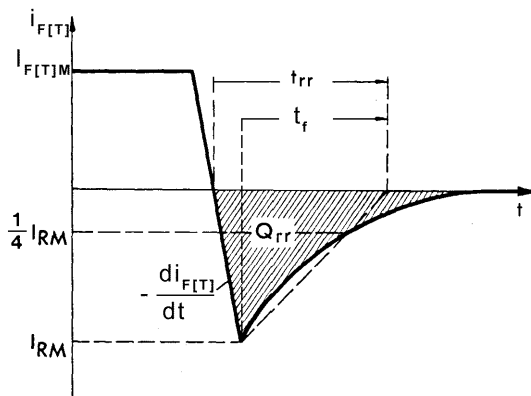

Fig. 1 Current curve during diode/thyristor turn-off

The following relations exist between t_{rr}, Q_{rr}, the current fall time t_f and the peak reverse recovery current I_{RM} (cf. Fig. 1):

$$t_{rr} = I_{RM} / (-di_{F[T]}/dt) + t_f$$

$$t_{rr} = \sqrt{\frac{2 \cdot Q_{rr}}{(-di_{F[T]}/dt)}} + \frac{t_f^2}{4} + \frac{t_f}{2}$$

$$I_{RM} = 2 \cdot Q_{rr} / t_{rr}$$

$$I_{RM} = \sqrt{2 \cdot Q_{rr} \cdot (-di_{F[T]}/dt) + \frac{t_f^2}{4} \cdot (-di_{F[T]}/dt)^2}$$

$$\frac{t_f}{2} \cdot (-di_{F[T]}/dt)$$

$$t_f = t_{rr} - I_{RM} / (-di_{F[T]}/dt)$$

If the fall rate of the forward current I_F [I_T] is very low, t_f will be small in comparison to t_{rr} and the equation can be simplified as follows:

$$t_{rr} = \sqrt{\frac{2 \cdot Q_{rr}}{(-di_{F[T]}/dt)}}$$

$$I_{RM} = \sqrt{2 \cdot Q_{rr} \cdot (-di_{F[T]}/dt)}$$

Further details, in particular with regard to fast diode switching, can be found in the section "Fast rectifier diodes" under "Diode turn-off".

Thermal resistances R_{th(x-y)} and thermal impedances Z_{th(x-y)}

Thermal resistances/impedances for the heat flow between points "x" and "y" are specified for the components. The indices used are as follows:

j - junction

c - case

s - heat sink

r - reference point

a - ambient

The contact thermal resistance case to heatsink $R_{th(c-s)}$ applies, provided the assembly instructions are followed. In such cases, the given dependences of the internal thermal resistance junction to case $R_{th(j-c)}$ on the current waveform and the current flow angle should take into account any deviations from the maximum instantaneous value of the mean junction temperature calculated.

Temperatures

The most important referential value for calculating limiting values is the maximum permissible virtual junction temperature T_{vj} . In the event of a circuit fault (e.g. when a fuse is activated), this value must not be exceeded (cf. "Surge on-state current"). Another important reference point for the permissible current capability is the case temperature T_c . The measuring point for T_c is as follows:

- In metal cases with threaded studs: the centre of one of the flats on the hexagonal base
- In capsule devices: any point on the outer edge of the round copper base

For components with solder terminals, a maximum permissible soldering temperature T_{solder} is specified for a maximum soldering duration. The permissible ambient conditions without current or voltage load are described, amongst other things, by the maximum permissible storage temperature T_{stg} .

Mechanical limiting values

The limiting values for mechanical load are specified in the datasheets, e.g.:

Mn : Max. tightening torque for terminal screws and fasteners

F : Permissible mounting force (pressure force) for capsule devices

a : Permissible amplitude of vibration or shock acceleration

Application Notes

The terms in [] apply solely to thyristors. For further details, please refer to the sections on thyristors, rectifier diodes and fast rectifier diodes.

Voltage class selection

The table below contains the recommended voltage class allocations for the repetitive peak reverse voltage V_{RRM} , $[V_{DRM}]$ of diodes [thyristors] and rated AC input voltage V_{VN} . The values specified refer to rectifier applications (samples).

Rated AC voltage L-L	Recommended peak reverse voltage
V_{VN} / V	$V_{RRM}, [V_{DRM}] / V$
60	200
125	400
250	800
380	1200
400	1400
440	1400
460	1600
500	1600
575	1800
660	2200
690	2200
1000	3000

As detailed in the technical explanations, the maximum permissible value for direct reverse voltages (continuous duty) across diodes (V_R) [or thyristors (V_D , V_R)] in stationary operation is $0.7 V_{RRM}$ [$0.7 V_{DRM}$] in all applications.

Overvoltage protection

RC snubber circuits are often connected in parallel to the diode [thyristor] to provide protection from transient overvoltage, although in some cases varistors are used. Due to the RC circuit the rate of rise of voltage is limited during commutation.

For higher circuit requirements, the RC circuit design should first be tested experimentally. The section SEMIPACK contains sample resistance and capacitance values recommended by SEMIKRON for standard line applications.

Over-current and short circuit protection

If short circuit protection is required for the diodes [thyristors], (ultra fast) semiconductor fuses are used. These are to be dimensioned on the basis of the forward current and i^2t value. Other types of protection for high current circuits are, for example, fuses which isolate damaged diodes [thyristors] from a parallel connection. To protect components from statically non-permissible high overcurrents, it is possible to use magnetic or thermal overcurrent circuit breakers or temperature sensors on the heat sinks, although these do not detect dynamic overload within a circuit. For this reason, temperature sensors are used mainly with forced air cooling in order to prevent damage to the diodes [thyristors] in the event of fan failure.

Permissible overcurrents

The permissible forward currents for temporary duty or intermediate operation, as well as for frequencies below 40 Hz are to be calculated on the basis of the transient thermal impedance or the thermal impedance under pulse conditions so that the virtual junction temperature T_{vj} does not exceed the maximum permissible value at any time.

Assembly instructions

The contact surface of the heatsink must be flat and clean. Before tightening, a thin layer of a thermal compound must be applied to the mating surface between the base of the thyristor and the heat sink, as well as to the thread and diode [thyristor] contact surface. The tightening torque values M specified in the datasheets must be observed (dynamometric key). The heat sinks should be mounted in such a way that the cooling fins are parallel to the flow of cooling air, which in most cases is in the vertical direction. In the case of natural cooling, the entire device should be constructed in such a way that a "chimney effect" is produced, in doing so creating a flow of air from the bottom to the top of the device.

The ceramic or glass seals for the anode/cathode and for the gate connections should not be subjected to mechanical stress during assembly or operation. The soldering eyes of small components, for instance, should be soldered to flexible leads and not screwed to rigid terminals. The maximum soldering temperature of 260 °C must not be exceeded.

Special assembly instructions for capsule thyristors

In order to obtain the maximum possible current from a capsule thyristor, double-sided cooling is normally used (DSC), although single-sided cooling (SSC) may be used in some special cases. For this reason the capsule thyristor is clamped between two heat sinks. For double-sided cooling, the specified thermal resistances apply to both heat sinks.

The following assembly instructions for double-sided cooling are also applicable to single-sided cooling, provided appropriate modifications are carried out: in order to guarantee good electrical and thermal contact the contact surfaces of both heat sinks must be metallic bright and free from impurities or other foreign matter. The maximum permissible unevenness of the contact surfaces is 10 µm, the maximum roughness likewise 10 µm. The contact surfaces should be coated by a thin layer (approx. 10 µm) of thermal compound, e.g. Electrolube 2 GX, SEMIKRON ident No. 30147770. The clamp must be shaped such that one of the two heat sinks can move freely during assembly. For this reason, in the SEMIKRON clamping devices one of the two mounting clamps forms a pivoting support (contact between spherical and flat surface). The second mounting clamp should be shaped in such a way that it doesn't deform when the screws are tightened. The heat sink which forms the pivoting support with the clamping device must move freely. This means that this heat sink must not contain any mechanical connections to other heat sinks or support elements. The electrical connection between this heat sink and the corresponding busbar must be made using a flexible lead.

Assembling capsule thyristors using the MC-type clamps

The contact surfaces of the heat sinks for the diode [thyristor] and the current take-off points must be bare metal. If

they are aluminium, the oxide layer must be removed with an abrasive sponge prior to assembly. In the case of plated surfaces, a solvent is sufficient for cleaning purposes. This also applies to the contact surfaces of thyristors. Both mating surfaces are then coated with a thin layer (approx. 10 µm) of a filler free thermal compound. For even distribution, we recommend using a rubber roller to do so. Each contact surface of the diode [thyristor] should now be placed onto the mating surface of the respective heat sink and twisted backwards and forwards by hand, at the same time applying a firm pressure. Note that the centre pin (9) must first be placed in position. When the diode [thyristor] is removed from the heat sink, the mating surfaces must be uniformly coated with the heat sink compound. If this is not the case, the surfaces must be thinly recoated. The clamp is then positioned such that the cross piece (5) and pressure plate (4) with the tension bolts (10) is at the top. The cross piece (3) and pressure plate (4) is inserted from below, and the two tension bolts (10) are tightened alternately until a slight resistance is felt. Now check that both cross pieces (3) and (5) are parallel. To do so, it is sufficient to measure the lengths of the ends of the bolts protruding from the bottom of the two cross pieces (3). For the cross pieces to be parallel, the bolt ends must be of equal length. The two tension bolts (10) should now be tightened alternately up to the point where the metal gauge (8) can be easily moved. Under no circumstances should the tension bolts be tightened beyond this point, as doing so would mean that the permissible mounting force has been exceeded. For the same reason, the pre-set nut (6) of the cup washer assembly (7) should never be adjusted. The metal gauge (8) must be properly secured to prevent it from falling out.

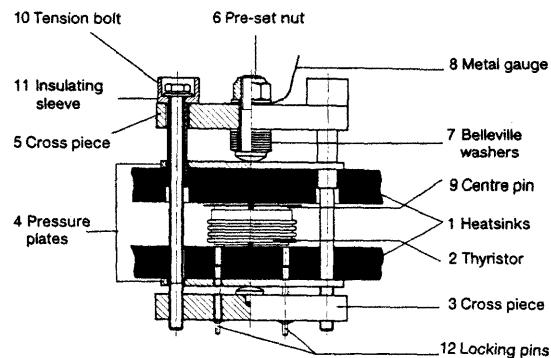

Fig. 2 SEMIKRON MC-type clamp

Assembling and disassembling capsule thyristors

Capsule thyristors contain thin layers of precious metal between the silicon chip and the hard metal contacts. When the capsule is pressed, these layers are deformed in order to provide intimate contact between the hard surfaces. If the diode [thyristor] is assembled and disassembled too often (and shaken when loose), the contacts may deteriorate as a result of component displacement. Any measurements and tests should therefore be carried out with the lowest mounting force F specified. For blocking voltage measurements, 80 % of the lowest mounting force is sufficient.

Thyristors

Type Designation System

① ② ③ ④ ⑤ ⑥

SK T 100 / 12 E UNF

① SEMIKRON component

② Thyristor

③ Rated current (I_{TAV} [A])

④ Voltage class (V_{DRM} , V_{RRM} [V] / 100)

⑤ dv/dt class

D: 500 V/μs

E: 1000 V/μs

⑥ Special design with UNF thread

Captions of the Figures

Fig. 1

Left: Mean power dissipation P_{TAV} as a function of the mean on-state current I_{TAV} for d.c. (cont.), sinusoidal half waves (sin. 180) and square-wave pulses (rec. 15...180), typical values.

Right: Mean power dissipation P_{TAV} as a function of the ambient temperature T_a (temperature of the cooling air flow) for different thermal resistances (junction to ambient air) $R_{th(j-a)}$ (typical values).

With the help of the thermal resistance junction to ambient air $R_{th(j-a)} = R_{th(j-c)} + R_{th(c-a)}$ obtained from Fig. 5 for the given current waveform, the given current flow angle and the intended heat sink, Fig. 1 can be used to derive the maximum permissible mean on-state current for a given ambient temperature and vice versa.

Fig. 2 Max. permissible mean on-state current I_{TAV} as a function of the case temperature T_c for d.c. (cont.), sinusoidal half waves (sin. 180) and square-wave pulses (rec. 15...180).

Fig. 3 Typical recovery charge Q_{rr} for the given junction temperatures as a function of the rate of fall of the on-state current $-di_T/dt$ during turn-off. Parameter: peak on-state current I_{TM} before commutation.

Fig. 4 Transient thermal impedance Z_{th} for d.c. as a function of the time t elapsed after a step change in power dissipation; the transient thermal impedance under pulse conditions $Z_{th(p)}$ across a range of 40 to 200 Hz may be calculated by adding the tabulated values for $Z_{th(z)}$ and $Z_{th(t)}$, which can be taken from this graph.

Fig. 5 Thermal resistance (junction to case) $R_{th(j-c)}$ as a function of the current flow angle Θ for 40 to 200 Hz for part sinusoidal half waves (sin.) and for square-wave pulses (rec.). The value $R_{th(j-c)}$ (cont.) applies to d.c.

Fig. 6 Forward characteristics: on-state voltage V_T as a function of the on-state current I_T ; typical and maximum values for $T_{vj} = 25\text{ °C}$ and T_{vjmax}

Fig. 7 Mean power loss P_{TAV} as a function of the mean on-state current I_{TAV} in the overcurrent range for d.c. (cont.), sinusoidal half waves (sin. 180) and square-wave pulses (rec. 60...180).

Fig. 8 Overload current characteristic: Ratio of permissible overload on-state current $I_{T(OV)}$ to surge on-state current I_{TSM} , shown as a function of the load period t for full or part sinusoidal half waves at between 50 and 200 Hz ($t \leq 10$ ms) or for a sequence of sinusoidal half waves at 50 Hz ($t > 10$ ms); Parameter: ratio V_R / V_{RRM} of the reverse voltage V_R , which lies between the given sinusoidal half waves, to the peak reverse voltage V_{RRM} .

Fig. 9 Gate voltage V_G as a function of the gate current I_G , indicating the regions of possible (BMZ) and certain (BSZ) triggering for various virtual junction temperatures T_{vj} . The current and voltage values of the triggering pulses must lie within the range of certain (BSZ) triggering, but the peak pulse power P_G must not exceed that given for the pulse duration t_p . Curve 20 V; 20 Ω is the output characteristic of suitable trigger equipment (example).

Technical Explanations

Critical rate of rise of on-state current $(di/dt)_{cr}$

Immediately after the thyristor has been triggered, only part of the chips conducts the current flowing, meaning that the rate rise of the on-state current must be limited. The critical values specified apply to the following conditions: repetitive loads of between 50 and 60 Hz; a peak current value corresponding to the crest value of the permissible on-state current for sinusoidal half waves; a gate trigger current that is five times the peak trigger current with a rate of rise of at least 1 A/μs. The critical rate of rise for on-state current falls as the frequency increases, but rises as the peak on-state current decreases. For this reason, for frequencies > 60 Hz and pulses with a high rate of rise of current, the peak on-state current must be reduced to values below those given in the datasheets.

Critical rate of rise of off-state voltage $(dv/dt)_{cr}$

The values specified apply to an exponential increase in off-state voltage to 0.66 V_{DRM} . If these values are exceeded, the thyristor can break over and self trigger.

Latching current I_L

Minimum anode current which at the end of a 10 μs triggering pulse will hold the thyristor in its on-state. The values specified apply to the triggering conditions stipulated in the section on "Critical rate of rise of on-state current".

Holding current I_H

Minimum anode current which will hold the thyristor in its on-state at a temperature of 25 °C. If the thyristor is swit-

ched on at temperatures below 25 °C, the values specified might be exceeded.

Circuit commutated turn-off time t_q

The circuit commutated turn-off time lies in the μs range and constitutes the time required for a thyristor to discharge to allow it to take on forward voltage again. This value is defined as the time that elapses between zero crossing of the commutation voltage and the earliest possible load with off-state voltage. In the case of thyristors for phase-commutated converters and a.c. converters, the circuit commutated turn-off time is usually of no significance. For this reason, the datasheets contain typical values only, and no guarantee is given for these values.

Gate trigger voltage V_{GT} and gate trigger current I_{GT}

Minimum values for square-wave triggering pulses lasting longer than 100 μs or for d.c. with 6 V applied to the main terminals. These values will increase if the triggering pulses last for less than 100 μs , e.g. for 10 μs the trigger current would be greater by a factor of between 1.4 and 2. Firing circuits should therefore be arranged in such a way that trigger current values are 4 to 5 times larger than I_{GT} . If the thyristor is loaded with reverse blocking voltage, no trigger voltage may be applied to the gate in order to avoid a non-permissible increase in off-state power losses and the formation of hot spots on the thyristor chip.

Gate non-trigger voltage V_{GD} and non-trigger current I_{GD}

These trigger voltage and current values will not cause the thyristor to fire within the permissible operating temperature range. Inductive or capacitive interference in the triggering circuits must be kept below these values.

Time definitions for triggering

Fig. 3 shows the characteristics of gate trigger signal V_G and anode-cathode voltage V_{AK} , which define the time intervals for the triggering process

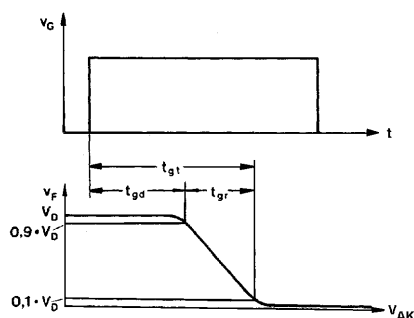

Fig. 3 Time definitions for thyristor triggering

Gate-controlled delay time t_{gd} : Time interval between the start of a triggering pulse and the point at which the anode-cathode voltage falls to 90 % of its starting value. The datasheet specifies a typical value which is applicable provided the following conditions are fulfilled:

- Square-wave gate pulse, duration 100 μs

- Anode-cathode starting voltage $0.5 V_{DRM}$
- On-state current after firing approx. $0.1 I_{TAV}$ @ 85 °C
- Junction temperature during firing approx. 25 °C

Gate controlled rise time t_{gr} : time interval within which the anode-cathode voltage falls from 90 % to 10 % of its starting value during firing

Gate trigger time t_{gt} : the sum of the gate controlled delay time t_{gd} and the gate controlled rise time t_{gr}

Application Notes

Thyristors connected in parallel

When connecting thyristors in parallel, it is important to ensure that equal current sharing occurs under both firing and steady state conditions. The triggering pulses must therefore have sufficiently steep leading edges (cf. "Critical rate of rise of on-state current"). It is also important to ensure the equal distribution of inductances and resistances in the main circuits. The difference between the on-state voltages of any thyristors to be connected in parallel should therefore be kept to a minimum. In order to take into account any remaining asymmetry, we recommend operating the thyristors in parallel with a maximum of 80 % of the maximum permissible mean on-state current calculated. It may be necessary to limit the rate of rise of current in an individual thyristor by chokes.

Thyristors connected in series

Thyristors can be connected in series to increase the off-state or blocking voltage. Here, it is important to ensure that equal voltage sharing occurs when the thyristors are in off-state (by using parallel resistors) as well as during commutation (by using RC elements connected in parallel). In order to ensure that the individual thyristors are triggered as simultaneously as possible, the gate trigger pulses must be large enough and have sufficiently steep leading edges. The voltage stress on each thyristor should be at least 10 % below that for single thyristor operation.

Rectifier Diodes

Type Designation System

① ② ③④ ⑤ ⑥

SK N a 20 / 13 UNF

① SEMIKRON component

② Configuration

N: Rectifier diode, anode to stud or capsule case

R: Rectifier diode, cathode to stud

No letter signifier: Rectifier diode, axial lead case

③ Avalanche diode

④ Rated current I_{FAV} [A]

⑤ Voltage class (V_{RRM} [V] / 100)

⑥ Special design with UNF thread

Captions of the Figures

Fig. 1

Left: Mean forward power dissipation P_{FAV} as a function of the mean continuous forward current I_{FAV} for d.c. (cont.), sinusoidal half waves (sin. 180) and square-wave pulses (rec. 15...180), typical values.

Right: Mean forward power dissipation P_{FAV} as a function of the ambient temperature T_a (temperature of the cooling air flow); Parameter: Thermal resistance case to ambient air $R_{th(c-a)} = R_{th(c-s)} + R_{th(s-a)}$. For the left vertically oriented dissipation P_{FAV} , the right vertically oriented case temperature T_c is permissible.

Recommended d.c. forward current max. $0.8 I_{FAV}$ for continuous duty. With the help of the thermal resistance junction to ambient air $R_{thja} = R_{thjc} + R_{thca}$, Fig. 1 can be used to derive the maximum permissible mean forward current for a given ambient temperature and vice versa.

Fig. 3 Maximum permissible mean forward current I_{FAV} as a function of the case temperature T_c for d.c. (cont.), sinusoidal half waves (sin. 180) and square-wave pulses (rec. 60° and rec. 120°). The diagrams for rec. 60° also apply to single-phase rectifier bridges with capacitive load.

Fig. 5 Transient thermal impedances junction to case $Z_{th(j-c)}$ and junction to heat sink $Z_{th(j-s)}$ as a function of the time t elapsed after a step change in power dissipation.

Fig. 6 Forward characteristics: Forward voltage V_F as a function of the forward current I_F ; typical and maximum values for $T_{vj} = 25\text{ °C}$ and T_{vjmax} .

Fig. 7 Overload current characteristics: Ratio of permissible overload forward current $I_{F(OV)}$ to surge forward current I_{FSM} , as a function of the load period t for full or part sinusoidal half waves at between 50 and 200 Hz ($t < 10\text{ ms}$) or for a sequence of sinusoidal half waves at 50 Hz ($t > 10\text{ ms}$); Parameter: Ratio V_R / V_{RRM} of the reverse

voltage V_R , which lies between the given sinusoidal half waves, to the peak reverse voltage V_{RRM} .

Fig. 9 Maximum permissible over-load current $I_{F(OV)}$ for intermediate operation (mean value), in relation to the mean forward current I_{FAV} , in dependence of the duty cycle ED. Parameter: (absolute) on-time t_e in seconds; the end points on the left of the characteristic apply to short-time operation (ED 0).

Fig. 10 Maximum surge current $I_{F(OV)}$ permissible under fault conditions only (crest values for 50 Hz sinusoidal half waves) as a function of the over-load period t following diode operation at $I_{FN} = 0.8 I_{FAV}$.

Fig. 11 Allowable peak reverse power dissipation P_{RSM} for avalanche diodes as a function of duration of surge t .

Short duration surges ($< 0.8\text{ s}$):

Non-repetitive surge during operation at $0.8 I_{FAV}$.

Long duration surges ($> 1\text{ s}$):

Continuous load with no load in forward direction.

Fig. 12 Maximum permissible peak forward current I_{FM} of a diode as a function of the duty cycle ED, Parameter: Number n of sinusoidal half waves during on-time t_e .

Fig. 13 Maximum permissible direct current I_d for two diodes in centre-tap connection (or four diodes in single-phase bridge) as a function of the duty cycle ED. Parameter: Number n of periods during conduction time t_e .

Fig. 14 Maximum permissible mean forward current I_{FAV} of a diode with axial leads as a function of the reference point temperature T_r , Parameter: Length L of the leads from the case to the reference points.

Fig. 15 Reverse current I_R (upper value of parameter spread) as a function of the virtual junction temperature T_{vj} for repetitive peak reverse voltage V_{RRM} .

Fig. 16 Thermal resistance junction to reference point $R_{th(j-r)}$ of a diode with axial wire leads as a function of the length L of the leads from the case to the reference points.

Technical Explanations

Breakdown voltage for avalanche diodes (avalanche breakdown voltage) $V_{(BR)}$

In avalanche diodes, when this voltage (indicated by the suffix a in the type designation) is reached, the reverse current begins to rise steeply. Peak voltages which exceed this value will cause a controlled breakdown on the whole diode area (avalanche). This breakdown is permissible for a brief period until the given maximum allowed avalanche power dissipation is reached.

Non-repetitive peak reverse power dissipation P_{RSM} of avalanche diodes

Maximum permissible, non-repetitive power dissipation in avalanche operation (breakthrough) for the pulse duration specified.

Thermal resistance junction to ambient air R_{thja} of diodes with axial wire leads

For diodes which are not designed primarily to transfer heat via a heat sink or a cooling plate, the thermal resistance junction to ambient air $R_{th(j-a)}$ is specified for a leaded diode integrated in the circuit via solder connections. Here, heat transfer via the terminals plays a very important role. For this reason, the values only apply if the following conditions are met: the diode is located directly on the PCB, the tracks on the circuit board are between 2 and 3 mm wide and entirely tinned (with normal thickness). Diodes with wire leads can also be mounted at a distance of 5...10 mm from the PCB. This causes the thermal resistance to decrease by approx. 10...15 % due to heat transfer to the ambient air through the wires. If the diode is located directly on the PCB, the thermal resistance can be reduced by a further 25...30 % using extremely wide, fully tinned tracks. If the diode is mounted using screw connections or soldering to fins, the thermal resistance will be approximately 20 % less than the value specified in the datasheets.

Application Notes

Assembly recommendations for SKN 4000 and SKN 6000

Fig. 4 shows an example of an SKN 4000 / SKN 6000 diode mounted between two water-cooled blocks.

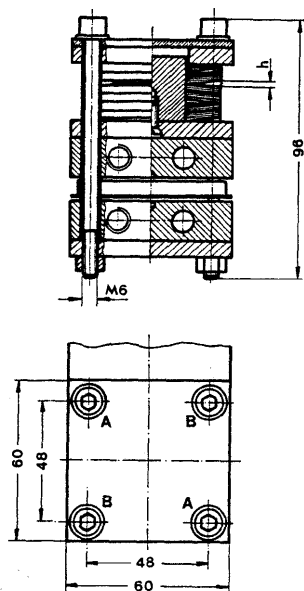

Fig. 4 Sample assembly of SKN 4000 / SKN 6000 diode between two water-cooled blocks.

To assemble, first tighten the screws by hand. Then a socket wrench should be used to gradually tighten the screws in the order of A-A-B-B until the specified force of (27 ± 3) kN is reached. When doing so, ensure that the clearance is identical across the entire diode at all times. After a diode has been in operation for some time, disassembly and re-assembly are not recommended, as micro-movements caused by thermal expansion lead to an adjustment

in the surfaces of the heat sink and the case which cannot be re-obtained when the diode is reassembled. As a result, the thermal resistance may increase.

Diodes connected in parallel

When connecting diodes in parallel, it is important to ensure that equal current sharing occurs in the main circuits (connecting points, conductor arrangement and length). For this reason the diode connections should be kept as symmetric as possible, as doing so will prevent differences in line impedances occurring. The forward voltages of any diodes to be connected in parallel should therefore differ from one another as little as possible. In order to take into account any remaining asymmetry, we recommend operating parallel diodes with a maximum of 80 % of the calculated permissible mean on-state current.

Diodes connected in series

Diodes can be connected in series to increase the reverse voltage. Here, it is important to ensure that equal voltage sharing occurs when the diodes operate in reverse state (by using parallel resistors) as well as during commutation (by using RC elements connected in parallel). With avalanche diodes connected in series, these measures are often not necessary. The voltage stress across each diode should be at least 10 % lower than that for single diode operation.

Fast Rectifier Diodes

Type Designation System

① ② ③ ④ ⑤

SK N 60 F 12

① SEMIKRON component

② Configuration

N: Rectifier diode, anode to stud

R: Rectifier diode, cathode to stud

No letter signifier: Rectifier diode, axial wire leads

③ Rated current I_{FAV} [A]

④ Additional designation

F: Fast rectifier diode

⑤ Voltage class (V_{RRM} [V] / 100)

① ② ③ ④ ⑤

SK N 3F 20/12

① SEMIKRON component

② Configuration

N: Rectifier diode, anode to stud

R: Rectifier diode, cathode to stud

No letter signifier: Rectifier diode, axial wire leads

③ Reverse recovery time class (approximate t_{rr} [μ s] / 10)

④ Rated current I_{FAV} [A]

⑤ Voltage class (V_{RRM} [V] / 100)

Captions of the Figures

Fig. 1 Typical recovery charge Q_{rr} for square-wave pulse current as a function of the rate of fall of forward current di_F/dt ; Parameter: Peak forward current I_{FM} before commutation. The following applies to sinusoidal half waves: $di_F/dt = 3 \cdot I_{FM} / t_p$

Fig. 2 Typical peak reverse recovery current I_{RM} as a function of the rate of fall of forward current di_F/dt ; Parameter: Peak forward current I_{FM} before commutation. The following applies to sinusoidal half waves: $di_F/dt = 3 \cdot I_{FM} / t_p$

Fig. 3 Transient thermal impedances junction to case $Z_{th(j-c)}$ and junction to heat sink $Z_{th(j-s)}$ as a function of the time t elapsed after a step change in power dissipation

Fig. 4 Forward characteristics: Forward voltage V_F as a function of the forward current I_F ; typical and maximum values for room temperature and high temperatures

Fig. 5 Overload current characteristics: Ratio of permissible mean forward current $I_{F(OV)}$ to the surge forward current I_{FSM} , as a function of the load period t for sinusoidal half waves; Parameter: Ratio of V_R / V_{RRM} of the reverse

voltage V_R , which lies between the given sinusoidal half waves, to the peak reverse voltage V_{RRM}

Fig. 6 Typical characteristics of peak reverse recovery current I_{RM} and reverse voltage V_R during turn-off; Parameter: Rate of fall of forward current - di_F/dt

Technical Explanations

Total power dissipation P_{TOT}

The total power dissipation P_{TOT} essentially comprises the forward power dissipation ($f \cdot W_F$), turn-off losses $f \cdot V_R \cdot Q_f$ (cf. Fig. 4) and off-state power losses $f \cdot V_R \cdot I_{RO} \cdot t_R$ (with negligible turn-on losses):

$$P_{TOT} = f \cdot W_F + f \cdot V_R (Q_f + I_{RO} \cdot t_R).$$

Q_f is the charge flowing out of the fast diode during the reverse current fall time t_f , I_{RO} is the reverse d.c. current given in Fig. 5, and t_R is the time period during which the reverse voltage V_R is applied across the diode:

$$t_R = t_c - t_p = \frac{1}{f} - t_p$$

Between Q_f and the recovery charge value specified in the datasheets, the following applies approximately to most fast diodes:

$$Q_f = Q_{rr} - \frac{I_{RM}^2}{2 \cdot (-di_F/dt)} \approx \frac{1}{4} \cdot Q_{rr} \dots \frac{1}{2} \cdot Q_{rr}$$

P_{TOT} determines the max. permissible thermal resistance $R_{th(j-a)}$ between junction and ambient air:

$$R_{thja} = \frac{T_{vj} - T_{amb}}{P_{TOT}}$$

Diode turn-off

Fig. 5 shows, on the example of the current curve illustrated in Fig. 1, the definition of important parameters for diode turn-off.

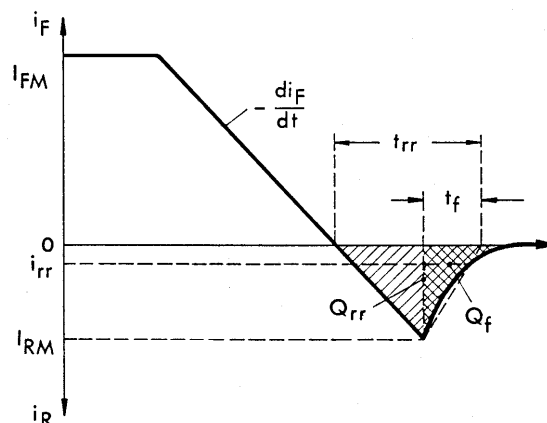

Fig. 5 Current curve for diode turn-off

Reverse recovery time t_{rr}

Time between the zero crossing of the falling current and the point at which the reverse current (approximately) reaches the stationary value.

Reverse current fall time t_f

Period during which the diode reverse current falls from its maximum value I_{RM} to the stationary value I_{RO} during turn-off.

Analytical description of the turn-off process

The following approximate correlation exists between reverse recovery time t_{rr} , recovery charge Q_{rr} and peak reverse recovery current I_{RM} :

$$t_{rr} = \frac{I_{RM}}{\left(-\frac{di_F}{dt}\right)} + t_f = \sqrt{\frac{2Q_{rr}}{\left(-\frac{di_F}{dt}\right)} + \frac{t_f^2}{4}} + \frac{t_f}{2}$$

$$t_f = t_{rr} = \frac{I_{RM}}{\left(-\frac{di_F}{dt}\right)}$$

$$Q_f = \frac{1}{2} \cdot I_{RM} \cdot t_f = Q_{rr} - \frac{I_{RM}^2}{2 \cdot \left(-\frac{di_F}{dt}\right)}$$

$$I_{RM} = \frac{2Q_{rr}}{t_{rr}} = \sqrt{2Q_{rr} \cdot \left(-\frac{di_F}{dt}\right) + \frac{t_f^2}{4} \cdot \left(-\frac{di_F}{dt}\right)^2} - \frac{t_f}{2} \cdot \left(-\frac{di_F}{dt}\right)$$

Application Notes

Fast diodes connected in parallel

When connecting fast diodes in parallel, it is important to ensure that equal current sharing occurs within the circuit (connecting points, conductor arrangement and length). For this reason, the diode connections should be kept as symmetric as possible, as doing so will prevent differences in line impedances occurring. The forward voltages of any diodes to be connected in parallel should therefore differ from one another as little as possible. In order to take into account any remaining asymmetry, we recommend operating the parallel diodes with a maximum of 80 % of the calculated permissible mean on-state current.

Fast diodes connected in series

Fast diodes can be connected in series to increase the reverse voltage. Here, it is important to ensure that equal voltage sharing occurs when the diodes operate in reverse state (by using parallel resistors) as well as during commutation (by using RC elements connected in parallel). The voltage stress across each diode should be at least 10 % lower than that for single diode operation.