

# Hardened steel way slides

A wide range of sizes for processes  
requiring precision linear motion

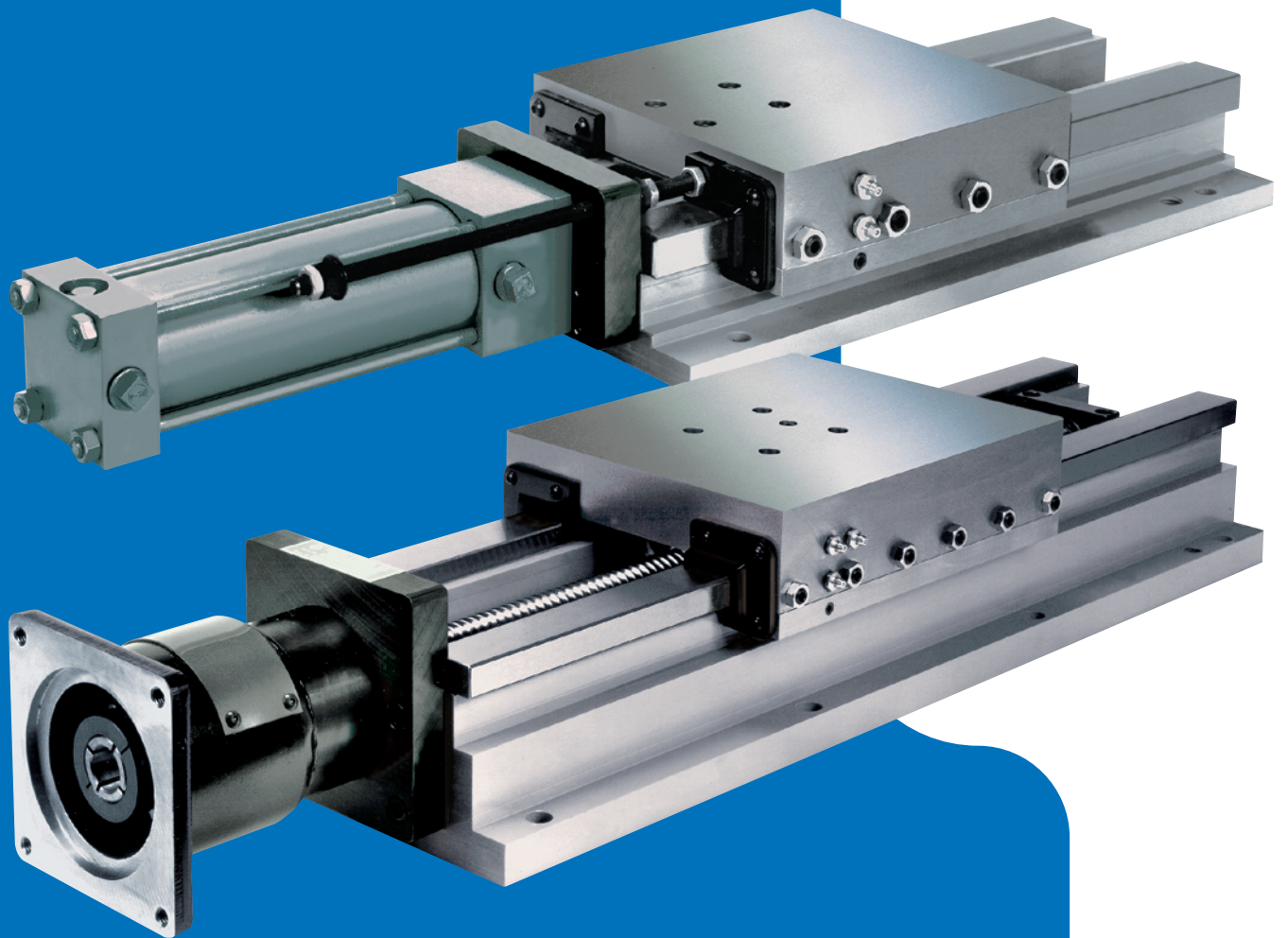

# Complete SKF slide selection

## Hardened steel way slides\*

Basic and drive equipped:

This catalog contains complete hardened way slide specifications

- 5" to 32" widths
- Travel and slide lengths built-to-order
- Several drive styles
- Production cycle durability
- Good for heavy machining applications

\*Visit [www.skfpt.com](http://www.skfpt.com) for 3D and 2D CAD files.



## Dovetail slides\*

ND (NextDay) line:

See catalog no. 400 for specifications

(In stock-ships in one business day from order)

- Immediate delivery off-the-shelf product
- In widths of 4", 6", 8", 10"
- Saddle travels of 4", 6", 8", 10"
- Reversible screw drive end and gib side
- Includes holes for mounting and compounding
- Matching angle brackets



L & H tool slide line:  
Catalog no. 400

- 2", 3", 4", 6", 8" widths
- Lead screw drives
- Off-the-shelf product

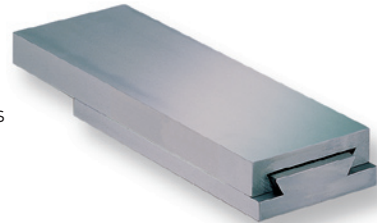

CP line:

Catalog no. 400

- 4", 6", 8" widths
- Air or hydraulic cylinder drives
- Plate mounted

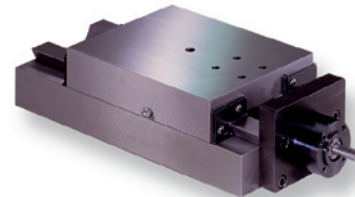

DC line:

Catalog no. 400

- 2" to 20" widths
- Length and travels built-to-order
- Several drive styles

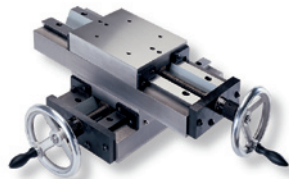

\*Visit [www.skfpt.com](http://www.skfpt.com) for 3D and 2D CAD files.

## Linear slides\*\*

Basic and drive equipped:

See catalog no. 201 for specifications

- 9" to 24" widths
- Ball or roller styles
- Used for high-speed applications
- High-speed drives
- Pre-loaded bearings

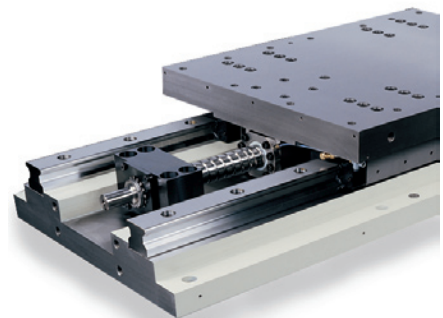
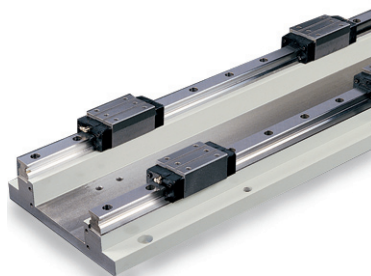
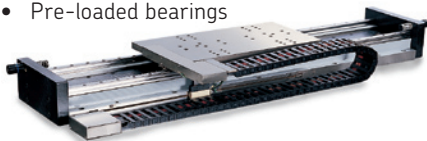

\*\*CAD and 3D files are available upon request.

# Hardened steel way slides

## SKF Precision Technologies' solutions for machine tool builders and users

### Take advantage of exclusive SKF technologies craftsmanship.

Whether your end application is a special machine or an OEM product line, SKF Precision Technologies' Grafton, WI plant — along with SKF facilities worldwide — assure you responsive engineering, precision manufacturing and prompt, efficient, after-sale service.

SKF Precision Technologies' slide assemblies are designed and built for smooth, accurate, long-life operation. Both the base and saddle are made from close-grained cast iron of 40,000 psi minimum tensile and are properly normalized for maximum stability. Both saddle and base are machined and ground parallel on top and bottom surfaces after assembly for a flat, accurate mounting surface. The saddle and base may be easily drilled, tapped or machined to accommodate specific mounting requirements. Saddle wear surfaces are lined with low friction bearing material, accurately ground and oil grooved to ensure adequate lubrication.

SKF Precision Technologies uses an ultra-high-precision Favretto way grinder with a horizontal and universal grinding head, capable of adjustment in one degree increments, to maintain accurate tracking of hardened steel way slide assemblies. The top, bottom and side of the ways are ground without resetting the base; saddle mating

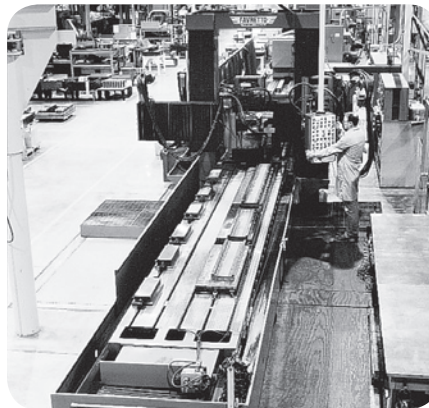
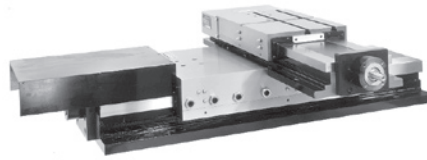

surfaces are ground in a similar manner. Ways can be accurately ground up to 20 feet in length.

Reduce your design and manufacturing time and costs. SKF Precision Technologies standard slide assemblies give you substantial dollar savings wherever in-line precision movements are required in your special or standard mechanical equipment. SKF Precision Technologies' slide modules can be easily assembled together or with other SKF Precision Technologies' modular components to build special production machines quickly and efficiently. Slides are available in sizes from 5-inch to 32-inch widths, saddle lengths to 60 inches, and base lengths to 120 inches. Longer lengths are available upon request.

For prompt service, please provide complete information with the order. You can readily build up the slide model number as you decide on the section, width, saddle length, base length, type of drive and travel. See "model number code" on page 7.

SKF Precision Technologies Inc. is a leading global supplier of machine tool automation components. SKF Precision Technologies' facilities, equipment and application engineering assistance help solve your most challenging design problems. Our ISO 18000 quality standards assure that our products have the highest accuracy, reliability, precision and durability.

## Table of contents

Product features.....	4	Acme lead screw.....	17
Application engineering data.....	5, 6	Ball lead screw.....	18
Ordering information.....	7	Hydraulic cylinder, adjustable end stops.....	19
HWS section:		Air cylinder, stop rod and air cylinder	
Basic.....	8	hydraulic-check, stop rod.....	20
Acme lead screw.....	9	Specials.....	21, 22
Ball lead screw.....	10	Accessories.....	23, 24
Hydraulic cylinder, internal.....	11, 12	Idea bulletins.....	25-31
Hydraulic cylinder, stop rod.....	13		
Air cylinder, stop rod and air cylinder			
hydraulic-check, stop rod.....	14		
HWL section:			
Basic.....	15		
Hydraulic cylinder, stop rod.....	16		

The Engineering Department of SKF Precision Technologies, reserves the right to change specifications without notice. Do not base final decisions on catalog drawings — ask for a certified print when you order a slide. If servicing should be required on any SKF Precision Technologies' slide, we suggest the unit be returned for factory service to assure optimum performance and life. For non-standard applications (e.g. hardened way slides with high-frequency and short stroke) contact SKF Precision Technologies for best solutions.

All dimensions are in inches unless otherwise indicated.

# Product features

## Ten basic parts

- 1 **Lubrication fitting:** For pressure gun lubrication; can be removed for manual or automatic lubrication systems, see "Accessories" on page 23. Lubricate with *Mobil Vactra #2* oil or equivalent.
- 2 **Wiper:** Provide protection to way surfaces from chips, dirt and other contaminants. Made from molded neoprene with a steel retainer.
- 3 **Saddle\*:** Moving member and female section. Manufactured from 40,000 psi close grain cast iron normalized for maximum stability. Wear surfaces are lined with low-friction bearing material, accurately ground and oil grooved to ensure adequate lubrication.
- 4 **Retainer\*:** Retains the saddle to the base. Made from finish-ground, low-carbon steel with wear surfaces lined with low-friction bearing material.
- 5 **Way:** Saddle tracking wear surface. Manufactured from high-carbon steel and hardened. Bonded and fastened to base before finish grinding.
- 6 **Base:** Stationary member and male section. Made from 40,000 psi close-grain cast iron, normalized for maximum stability.
- 7 **Gib screw nut:** Locks the gib screw in place to maintain the adjustment on the gib.
- 8 **Gib screw:** Special socket-head screws properly spaced along one side of the saddle for adjusting the gib.
- 9 **Gib positioning pin:** For linear positioning of gib. Hollow pin mounted in lubrication hole.
- 10 **Gib\*:** Adjustable member for setting side clearance between ways and saddle. Made from low-carbon steel lined with low friction bearing material.

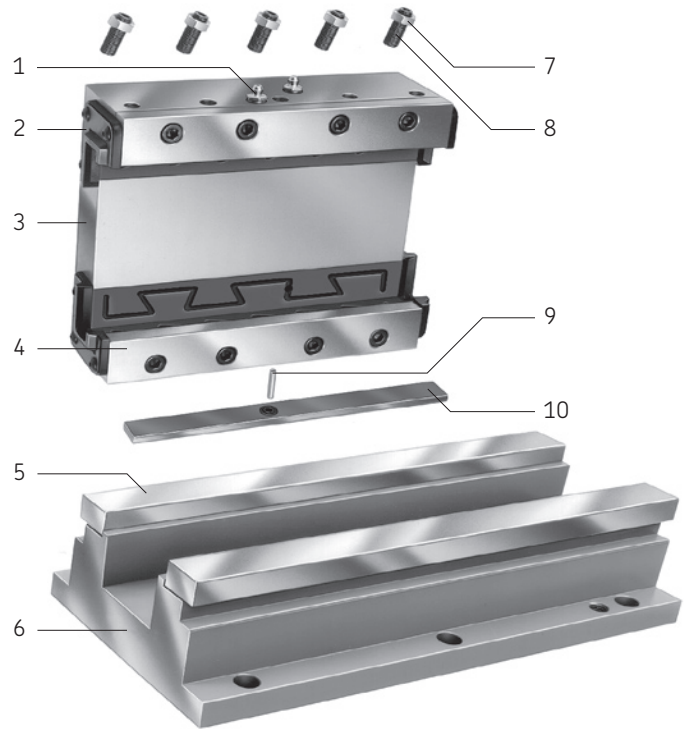

\*Low friction bearing material has a coefficient of friction 1/3 that of cast iron on steel and similar dynamic and static coefficients, which minimizes the stick-slip condition. Closer fits between the saddle and base can be obtained, which improves saddle tracking and positioning accuracy. Bearing material is standard on all HWS and HWL models. Slides without bearing material are available on request. **Caution: Low friction bearing material is not recommended in temperatures less than -60°F or greater than 150°F, and when fluorine-based coolants or chlorinated cutting oils are used.**

## Lubrication

*Mobil Vactra #2* oil or equivalent is recommended for lubricating slide ways. **Do not use grease!**

Use these charts and formulas as a guide to determine the lube area or the amount of lubrication required for the slide. Lubrication requirements may vary depending on your application. Consult factory for further assistance.

Model	B	C	D
HWS5	.88	.50	.11
HWS7, HWL7	1.19	.75	.16
HWS9, HWL9	1.38	.75	.17
HWS12, HWL12	2.12	1.12	.26
HWS15, HWL15	2.88	1.50	.35
HWS18, HWL18	3.25	1.75	.40
HWS24, HWL24	3.75	1.75	.44
HWS32	3.75	1.75	.44

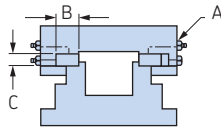

SL	A
5-18	4
19-36	8
37-60	12

SL = Saddle length (inches)  
 T = Travel (inches)  
 A = Number of lube points  
 B = Way width (inches)  
 C = Way height (inches)  
 D = Lube factor (cc/hr/in)

LB = Lube area/lube point top of way (in<sup>2</sup>)

LC = Lube area/lube point side of way (in<sup>2</sup>)

LD = Lube req. (cc/hr)

$$LB = \frac{(SL)(B)(4)}{A}$$

$$LC = \frac{(SL)(C)(4)}{A}$$

$$LD = (SL+T)(D)$$

## Hardened steel way slide tolerances\*\*

- Overall height..... = ± .005 in  
 Vertical tracking: (A)..... = .0005 in/3 ft  
 Horizontal tracking: (B)..... = .0005 in/3 ft  
 Parallelism: (C)..... = .001 in/ft  
 Saddle to base..... = .001 in/ft

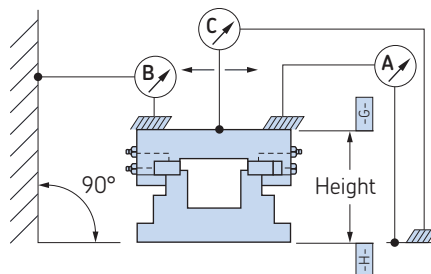

G .0005 in/ft      H .0005 in/ft

\*\* Higher accuracies available upon request.

## Slide mounting

Drawings at the right show the most common mounting positions of hardened steel way slides. When slides are mounted other than horizontal, the load capacity changes and in some cases lubrication holes and grooves have to be altered. *Specify if mounting is other than horizontal when ordering.*

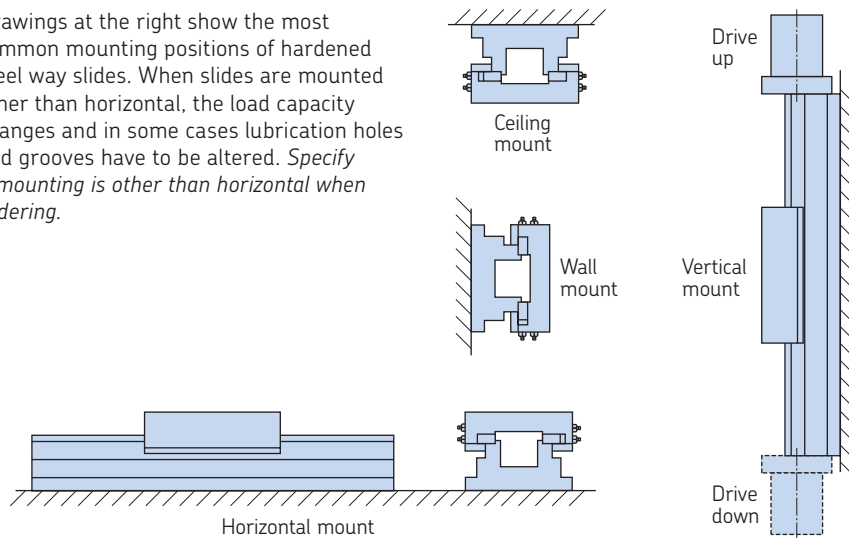

## Slide loading

Use this data as a guide to determine the size of a slide for a particular application. All values are for uniformly distributed loads and moments, and the saddle is assumed to be a rigid member. Some conditions may allow the use of higher load values (e.g. rough machining or positioning applications), while other conditions dictate the use of lower values (e.g. precision boring or grinding applications). For saddle lengths longer than two times the width, and if deflections are critical, please consult factory for load capacity.

Model	Load factors											
	D		U		S		W		T		L	
	Static	Dyn.	Static	Dyn.	Static	Dyn.	Static	Dyn.	Static	Dyn.	Static	Dyn.
HWS5	525	105	112	22	150	30	204	41	50	10	62	12
HWS7, HWL7	712	142	187	37	225	45	480	96	75	15	99	20
HWS9, HWL9	825	165	225	45	225	45	759	152	75	15	118	23
HWS12, HWL12	1275	255	300	60	337	67	1350	270	112	22	162	32
HWS15, HWL15	1725	345	450	90	450	90	2531	506	150	30	238	47
HWS18, HWL18	1950	390	525	105	525	105	3543	708	175	35	276	55
HWS24, HWL24	2250	450	600	120	525	105	5400	1080	175	35	316	63
HWS32	2250	450	600	120	525	105	7200	1440	175	35	316	63

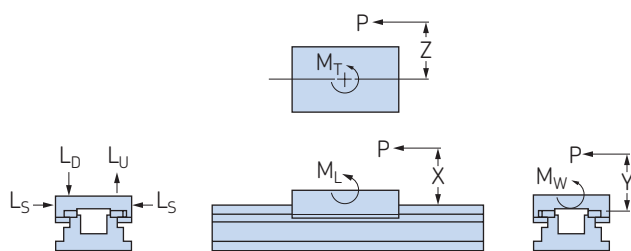

### Maximum load calculations:

$$L_D \text{ max.} = D \times SL \text{ (lbs)}$$

$$L_U \text{ max.} = U \times SL \text{ (lbs)}$$

$$L_S \text{ max.} = S \times SL \text{ (lbs)}$$

### Maximum moment calculations:

$$M_W \text{ max.} = W \times SL \text{ (in-lbs)}$$

$$M_T \text{ max.} = T \times (SL)^2 \text{ (in-lbs)}$$

$$M_L \text{ max.} = L \times (SL)^2 \text{ (in-lbs)}$$

### Slide loading definitions

A = Slide width (inches)

D = Down load factor

$L_D$  = Vertical load down (lbs)

$L_S$  = Horizontal load side (lbs)

$L_U$  = Vertical load up (lbs)

L = Length moment load factor

$M_L$  = Moment about saddle length (in-lbs)

$M_T$  = Moment about plane of saddle top (in-lbs)

$M_W$  = Moment about saddle width (in-lbs)

P = Load producing moment (lbs)

S = Side load factor

T = Top moment load factor

U = Up load factor

W = Width moment load factor

X = Distance from load P to slide way (inches)

Y = Distance from load P to slide way (inches)

Z = Distance from load P to center line of slide (inches)

SL = Saddle length engaged on base (inches)

# Application engineering data

## Slide thrust and torque

The force required to power the slide assembly ( $F_H$  and  $F_V$ ), includes the force to overcome all external loads as shown under "Slide loading" (page 5), plus the force required to power the saddle assembly times a factor of safety. The factor of safety is applied to ensure sufficient power to accelerate the load and overcome friction due to variables such as lubrication, machining tolerances, finish, etc.

The factor of safety depends on the type of drive used, see "FS" under "Slide thrust and torque definitions" below.

The torque required to accelerate or decelerate the slide is dependent upon the moving weight, screw size, force applied to the slide and rate of acceleration or deceleration. Please consult the motor manufacturer you selected for this analysis.

The thrust values obtained from the calculation must be checked against the maximum thrust capacities (pages 9-20), for the drive model being used. If acceleration time is critical or speeds above 350 ipm are required, please consult factory for power requirements.

### Slide thrust and torque definitions

- $F_H$  = Force req. to power slide horizontally (lbs)
- $F_V$  = Force req. to power slide vertically (lbs)
- $F_D$  = Force req. to overcome saddle drag (lbs)  
10 lbs - 100 lbs  
Drag force is affected by several factors including gib adjustment, way wipers, way covers, lubrication and slide size. Use lower values for smaller slides and higher values for larger slides.
- $F_{SLH}$  = Force to power saddle weight horizontally (lbs)
- $F_{SLV}$  = Force to power saddle weight vertically (lbs)
- $F_L$  = Force to overcome loads  $L_D$ ,  $L_U$ ,  $L_S$  (lbs)
- $F_{ML}$  = Force to overcome moment  $M_L$ , and load "P" (lbs)
- $F_{MW}$  = Force to overcome moment  $M_W$ , and load "P" (lbs)
- $F_{MT}$  = Force to overcome moment  $M_T$ , and load "P" (lbs)
- FS = Factor of safety  
Manual drives = 1.5  
Lead screw drives = 2  
Hydraulic cylinder drives = 2.5  
Air cylinder drives = 3
- $\mu$  = Coefficient of friction with lubrication  
.25 cast iron on hardened steel  
.08 low-friction bearing material
- SL = Saddle length (inches)
- WSL = Weight of saddle (lbs/in)
- H = Distance across ways (inches)  
See page 8 or 15 for "E" dimension.
- TH = Torque to power slide horizontally (in-lbs)
- TV = Torque to power slide vertically (in-lbs)
- TD = Torque to overcome drag of screw assembly  
See chart (in-lbs)
- K = Screw constant  
.64 Acme screw  
.20 ball screw
- L = Lead of screw (in/rev)  
See pages 9, 10, 17 and 18.

Model	$T_D$ (in-lbs)		
	Acme screw	Ball screw non-preloaded nut	Ball screw preloaded nut
HWS5, HWL7	8	5	-
HWL9	11	5	10
HWS7, HWL12	16	10	15
HWS9, HWL15	18	12	17
HWS12, HWL18	19	12	17
HWS15, HWS18, HWL24	21	15	20
HWS24, HWS32	26	20	25

#### Thrust calculations<sup>‡</sup>:

$$F_H = (F_D + F_{SLH} + F_L + F_{ML} + F_{MW} + F_{MT})FS$$

$$F_V = (F_D + F_{SLV} + F_L + F_{ML} + F_{MW} + F_{MT})FS$$

$$F_{SLH} = (\mu)(W_{SL})(SL)$$

$$F_{SLV} = (W_{SL})(SL)$$

$$F_L = (\mu)(L_D + L_U + L_S)$$

$$F_{ML} = (3\mu)(M_L/SL) + P$$

$$F_{MW} = (2\mu)(M_W/E) + (\mu)(P)$$

$$F_{MT} = (3\mu)(M_T/SL) + P$$

#### Torque calculations:

$$T_H = T_D + (K)(F_H)(L)$$

$$T_V = T_D + (K)(F_V)(L)$$

<sup>‡</sup> All forces, loads and moments must be added using correct signs positive or negative.

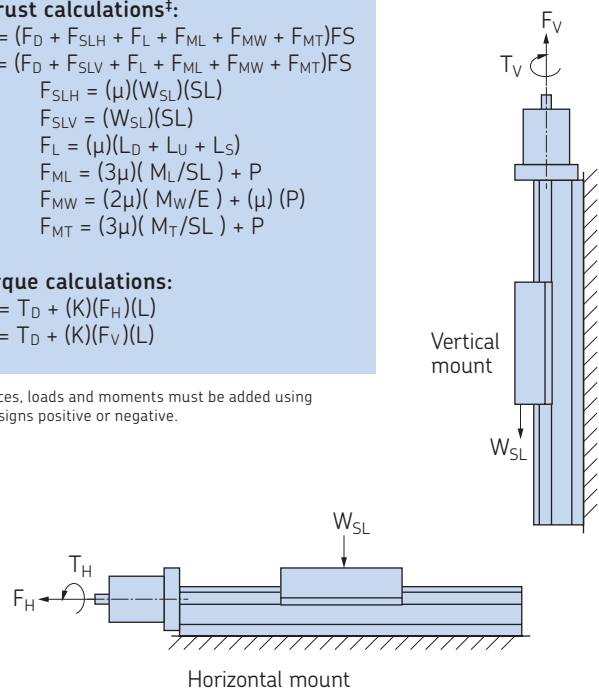

# Ordering information

## Building the slide model number

SKF Precision Technologies' hardened way steel slides are defined by using simple model numbers to define the standard features desired. The "HWL" and "HWS" slides offer a series of pre-engineered choices that have been application tested.

- 1 Select the section and width. This is the width (in inches) of the slide saddle. Refer to the data charts for specific dimensions.
- 2 Select saddle length. This is the length (in inches) of the slide saddle. Refer to the data charts for specific dimensions.
- 3 Select the base length. This is the length (in inches) of the slide base. Refer to the data charts for specific dimensions.
- 4 Choose a slide drive type. Select from 15 slide drive types to fit a variety of applications.
- 5 Select the travel. Specify the distance (in inches) that the saddle will travel. Refer to the data charts for specific dimensions.
- 6 Select accessories. Include accessories added to the slide. See pages 12, 23 and 24 for available accessories.

## Model number code

Slide section and width											Description	Code			
HWS5	HWL7	HWS7	HWL9	HWS9	HWL12	HWS12	HWL15	HWS15	HWL18	HWS18			HWL24	HWS24	HWS32
●	●	●	●	●	●	●	●	●	●	●	●	●	●	See catalog for min. & max. lengths	±
●	●	●	●	●	●	●	●	●	●	●	●	●	●	See catalog for min. & max. lengths	±
●	●	●	●	●	●	●	●	●	●	●	●	●	●	Acme screw in-line handwheel	A1
●	●	●	●	●	●	●	●	●	●	●	●	●	●	Acme screw right angle handwheel	E1
●	●	●	●	●	●	●	●	●	●	●	●	●	●	Rolled ball screw non-preloaded nut	D1▲
	●	●	●	●	●	●	●	●	●	●	●	●	●	Ground ball screw preloaded nut (inch)	D2▲
	●	●	●	●	●	●	●	●	●	●	●	●	●	Ground ball screw preloaded nut (metric)	D3▲
●	●	●	●	●	●	●	●	●	●	●	●	●	●	Rolled ball screw non-preloaded nut with motor mount	M1▲
	●	●	●	●	●	●	●	●	●	●	●	●	●	Ground ball screw preloaded nut (inch) with motor mount	M2▲
	●	●	●	●	●	●	●	●	●	●	●	●	●	Ground ball screw preloaded nut (metric) with motor mount	M3▲
	●	●	●	●	●	●	●	●	●	●	●	●	●	Hydraulic cylinder internal	H4
	●	●	●	●	●	●	●	●	●	●	●	●	●	Hydraulic cylinder internal adjustable end stops	H5
	●	●	●	●	●	●	●	●	●	●	●	●	●	Hydraulic cylinder partially internal	H6
	●	●	●	●	●	●	●	●	●	●	●	●	●	Hydraulic cylinder partially internal adjustable end stops	H7
●	●	●	●	●	●	●	●	●	●	●	●	●	●	Air cylinder stop rod	P2
●	●	●	●	●	●	●	●	●	●	●	●	●	●	Air cylinder stop rod parallel hydraulic check	P4
	●	●	●	●	●	●	●	●	●	●	●	●	●	Air cylinder stop rod in-line hydraulic check	P5
●	●	●	●	●	●	●	●	●	●	●	●	●	●	See catalog for min. & max. lengths	±

HWS9-12-24-H5-9 With side porting

**Accessories** must be specified when ordering. Be sure to include any additional information required when ordering accessories. See pages 12, 23 and 24 for accessories.

± Specify saddle length, base length and travel in inches.

▲ Specify maximum traverse rate for ball screw slides. Saddle in (ipm) or ball screw in (rpm).

# HWS section

## Standard profile basic

HWS basic hardened steel way slide assemblies are offered in eight sizes as shown in the chart below. Consult the factory for larger sizes.

Saddle lengths are available in one-inch increments up to 60 inches. Base lengths are available in three-inch increments from 9" to 30"; six-inch increments from 30" to 60"; and 12-inch increments from 60" to 120". Base lengths greater than 120 inches are available in 12-inch increments up to 240 inches maximum. This enables the designer to achieve an economical, compact machine package. The saddle is generally shorter than the base. Saddle length plus two inches for way wipers, plus the travel, equals the

base length (BL=SL+T+2). If the base does not calculate to a standard base length, adjust the saddle length or travel to suit a standard base length. Base lengths other than shown are available. The saddle, retainer and gib wear surfaces are lined with low-friction bearing material to reduce sliding friction.

A cavity is machined in the center of the base to provide space for a drive mechanism such as a lead screw or cylinder. HWS5 through HWS32 slides are shown on pages 9 through 14. Consult factory for other special drives to suit your particular applications. Prints will be furnished on request.

For accessories, see pages 12, 23 and 24.

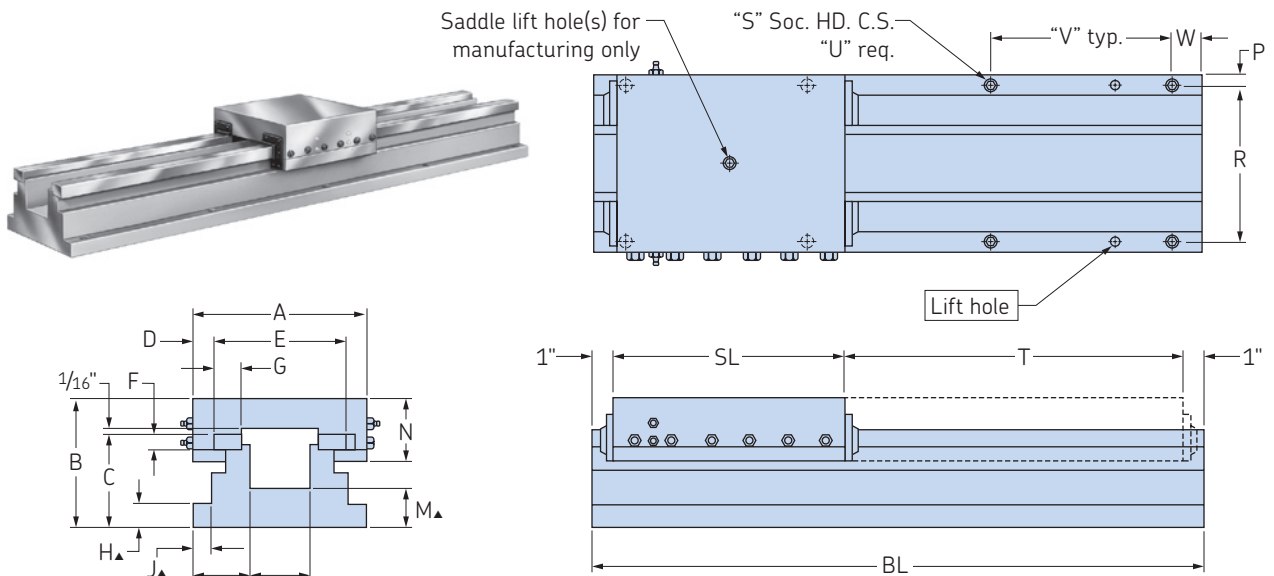

▲ Cast surface on HWS18, HWS24 and HWS32.

Model	SL 1-inch increments		BL*		Dimensions (inches)																Approx. weight (lbs) per inch length	
	Min.	Max.	Min.	Max.	A	B	C	D	E	F	G	H	J	K	L	M	N	P	R	S	SL	BL
HWS5	5	21	9	24	5	3 1/2	2 1/2	1 1/16	3 5/8	1/2	7/8	5/8	1 1/16	1 11/16	1 5/8	1 5/16	1 7/8	3/8	4 1/4	5/16	1 5/8	1 3/4
HWS7	7	36	12	72	7	5	3 5/8	1 5/16	5 5/8	3/4	1 3/16	3/4	7/8	2 3/8	2 1/4	1 1/2	2 5/8	1/2	6	3/8	3 1/4	3 7/8
HWS9	9	60	12	84	9	6 3/8	4 5/8	1 1/8	6 3/4	3/4	1 3/8	1	1	2 7/8	3 1/4	2	3 1/8	1/2	8	3/8	5	6 1/2
HWS12	12	60	15	96	12	7 1/2	5 1/2	1 1/2	9	1 1/8	2 1/8	1 1/4	1 3/8	4 1/8	3 3/4	2 3/4	4	5/8	10 3/4	1/2	8 1/8	10 1/2
HWS15	15	60	18	96	15	8 1/2	6 1/4	1 7/8	11 1/4	1 1/2	2 7/8	1 1/2	1 3/8	5 1/4	4 1/2	2 3/8	4 3/4	3/4	13 1/2	5/8	11 3/4	15
HWS18	18	60	21	120	18	10 1/2	7 3/4	2 1/4	13 1/2	1 3/4	3 1/4	1 7/8	3 3/8	6 3/8	5 1/4	2 5/8	5 3/4	1 5/8	14 3/4	3/4	17	19 3/4
HWS24	24	60	27	120	24	12	8 1/2	3	18	1 3/4	3 3/4	2 1/8	4	8 1/2	7	2 1/2	6 7/8	2 1/4	19 1/2	3/4	29 1/8	28 1/4
HWS32	32	60	36	120	32	12 1/2	8 1/2	4	24	1 3/4	3 3/4	2 1/8	5	10	12	3	7 3/8	2 1/4	27 1/2	3/4	41 1/4	36 1/4

\*Base lengths and mounting hole locations — dimensions (inches)

	9	12	15	18	21	24	27	30	36	42	48	54	60	72	84	96	108	120	132 through 240
U	4	4	6	6	6	8	8	8	8	8	10	10	10	10	12	12	12	14	Available in 12-inch increments. Consult factory for mounting locations.
V	6	9	6	7 1/2	9	7	8	9	11	13	11	12 1/2	14	17	16	18	20	19	
W	1 1/2	1 1/2	1 1/2	1 1/2	1 1/2	1 1/2	1 1/2	1 1/2	1 1/2	1 1/2	2	2	2	2	2	3	4	3	



# HWS section

## Acme lead screw (A1, E1)

Lead screw drives for hardened steel way slides are available in three different drive configurations.

A1 and E1 drives are used primarily for hand positioning and can be furnished with either an in-line drive or a 2:1 reduction, right-angle drive, which can be positioned eight ways as shown below. Please specify position number when ordering. Manual drives are furnished with a balanced handwheel, micrometer dial, needle bearing thrust assembly, an Acme lead screw ( $X_1$ ), and bronze nut. Acme adjustable nuts for reducing backlash (.001 inch minimum), or hexagon-end shaft extensions for wrench adjustments are available on request.

The base length is calculated as follows:  $(BL=SL+T+2)$ . If the base does not calculate to a standard length, adjust the saddle length or travel to suit a standard base length.

For accessories, see pages 23 and 24.

For dimensions not shown see "HWS" basic assembly on page 8.

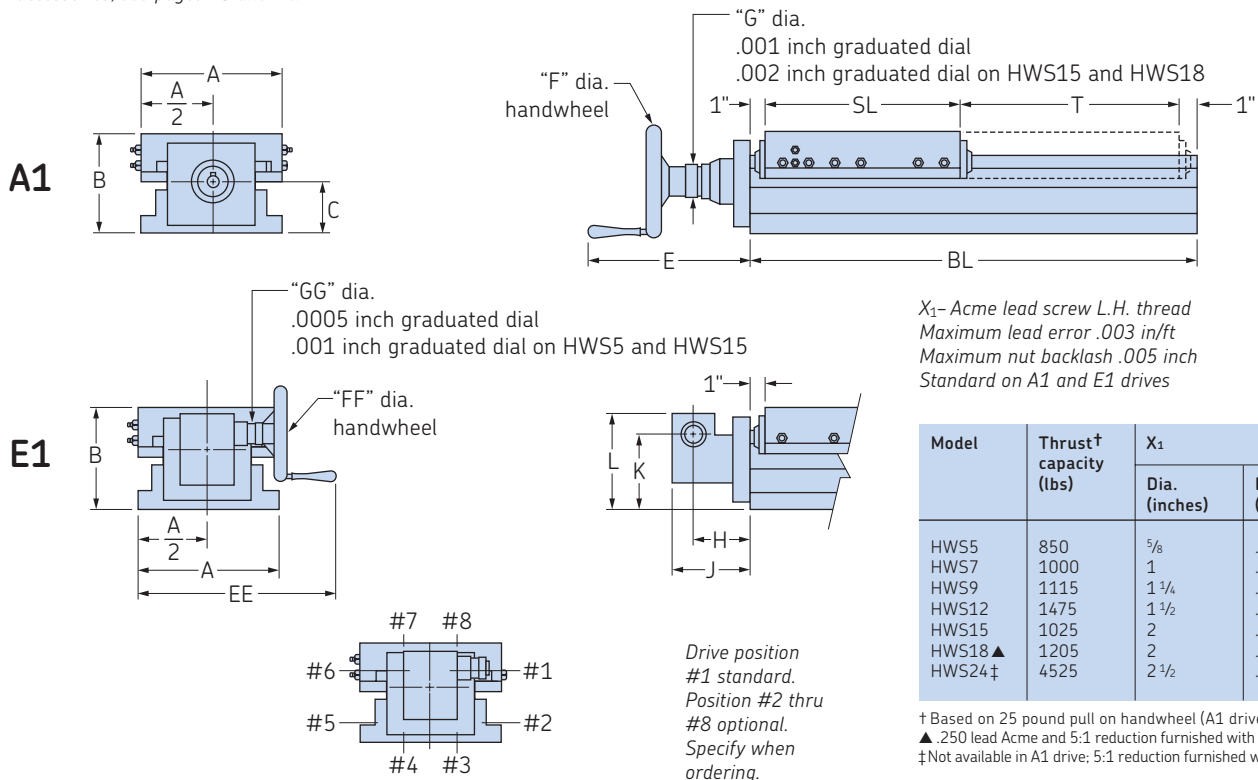

Model	1-inch increments				BL*		Dimensions (inches)														
	SL		T																		
	Min.	Max.	Min.	*Max.	Min.	Max.	A	B	C	D	E	EE	F	FF	G	GG	H	J	K	L	
HWS5	5	21	1	17	9	24	5	3 $\frac{1}{2}$	1 $\frac{13}{16}$	1 $\frac{13}{16}$	6 $\frac{5}{8}$	8 $\frac{3}{16}$	5	4	1 $\frac{5}{8}$	1	2 $\frac{5}{32}$	3	2 $\frac{15}{16}$	3	3 $\frac{13}{16}$
HWS7	7	36	1	63	12	72	7	5	2 $\frac{19}{32}$	2 $\frac{5}{8}$	8 $\frac{7}{8}$	10 $\frac{1}{8}$	6	5	2 $\frac{1}{4}$	1 $\frac{5}{8}$	3 $\frac{3}{8}$	4 $\frac{3}{16}$	4 $\frac{3}{32}$	5 $\frac{3}{8}$	
HWS9	9	60	1	73	12	84	9	6 $\frac{3}{8}$	3 $\frac{7}{16}$	3 $\frac{3}{8}$	9 $\frac{3}{8}$	13	7	6	2 $\frac{1}{4}$	1 $\frac{5}{8}$	3 $\frac{3}{8}$	4 $\frac{9}{16}$	4 $\frac{15}{16}$	6 $\frac{7}{32}$	
HWS12	12	60	1	81	15	96	12	7 $\frac{1}{2}$	4 $\frac{3}{8}$	4 $\frac{1}{2}$	11 $\frac{1}{4}$	16 $\frac{7}{16}$	9	7	3	2 $\frac{1}{4}$	4 $\frac{3}{32}$	5 $\frac{7}{8}$	6 $\frac{5}{8}$	8 $\frac{1}{4}$	
HWS15	15	60	1	79	18	96	15	8 $\frac{1}{2}$	4 $\frac{3}{4}$	4 $\frac{3}{8}$	12 $\frac{3}{8}$	18 $\frac{15}{16}$	12	9	3	2 $\frac{1}{4}$	4 $\frac{27}{32}$	6 $\frac{5}{8}$	7	8 $\frac{5}{8}$	
HWS18	18	60	1	100	21	120	18	10 $\frac{1}{2}$	6 $\frac{1}{4}$	5 $\frac{7}{8}$	14 $\frac{1}{8}$	21 $\frac{3}{8}$	14	12	4	3	7 $\frac{1}{8}$	9 $\frac{5}{16}$	9 $\frac{1}{4}$	10 $\frac{7}{8}$	
HWS24‡	24	60	1	94	27	120	24	12	—	6	—	27 $\frac{1}{8}$	—	12	—	3	7 $\frac{1}{8}$	9 $\frac{5}{16}$	9	10 $\frac{5}{8}$	
HWS32	32	60	1	86	36	120	32	12 $\frac{1}{2}$	—	6	—	—	—	—	—	—	—	—	—	—	—

\*Maximum travel based on 350 ipm saddle traverse.  
\*See page 8 for base lengths and mounting hole locations.

# HWS section

Ball lead screw  
(D1, D2, D3  
M1, M2, M3)

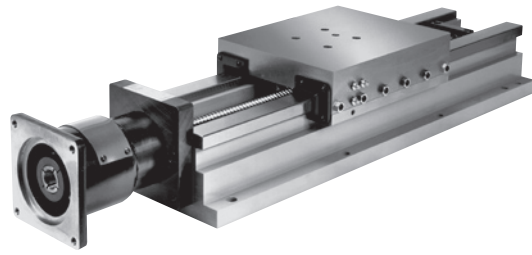

The D1, D2 and D3 drives are used for powered applications where the purchaser provides and mounts the driving source. These slides are equipped with a ball lead screw. Each slide has a thrust assembly, which uses a pair of preloaded ball bearings. D1 and M1 feature a rolled ball screw with non-preloaded ball nut. D2 and M2 inch or D3 and M3 metric feature a precision ground ball screw with preloaded ball nut. Preselected ball nuts with .005-inch maximum backlash are available on request for the D1 and M1 drive assembly. It is highly recommended that all ball screws are protected from contaminants or accidental damage from tools or work pieces.

Total lost motion of slide drive assembly includes backlash in nut, backlash in thrust assembly and deflection in the system due to load. Please consult the factory in applications where positioning is critical.

For accessories, see pages 23 and 24.

Please specify maximum traverse rate when ordering. Saddle in (ipm) or ball screw in (rpm).

## D1, M1 – Rolled ball lead screw R.H. thread

Maximum lead error .009 in/ft  
Maximum nut backlash .010 –.015 inch depending on screw size.

## D2, M2 – Ground ball lead screw R.H. thread

Maximum lead error .0005 in/ft  
Zero nut backlash.

## D3, M3 – Ground metric ball lead screw R.H. thread

Maximum lead error .04 mm/m (.0005 in/ft)  
Zero nut backlash.

## M1, M2, M3 – Motor mount for customer-supplied motor.

Consult factory for specifications.

For dimensions not shown, see "HWS" basic assembly on page 8.

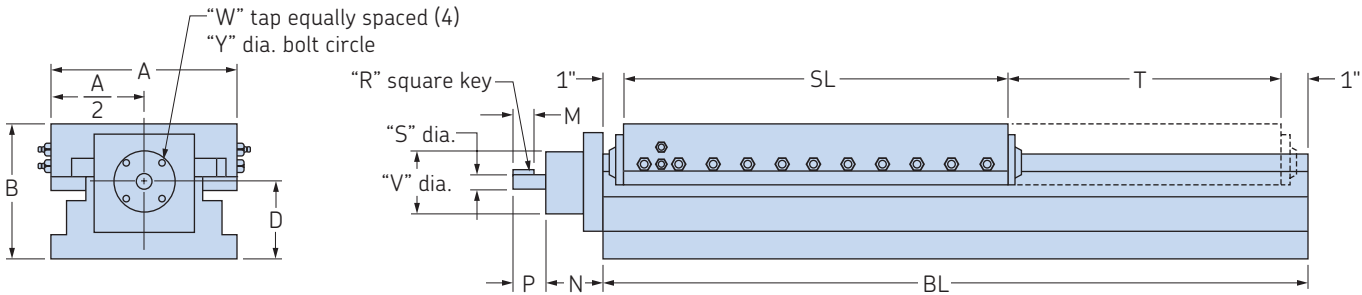

Model	D1, M1			D2, M2			D3, M3		
	Thrust capacity (lbs)	Dia. (inches)	Lead (in/rev)	Thrust capacity (lbs)	Dia. (inches)	Lead (in/rev)	Thrust capacity (lbs)	Dia. (mm)	Lead (mm/rev)
HWS5	740	5/8	.200	-	-	-	-	-	-
HWS7	2820	1	.250	2280	1	.250	2280	25	5
HWS9	3110	1 1/2	.250	2790	1 3/4	.250	2580	32	5
HWS12	3110	1 1/2	.250	3110	1 1/2	.250	2810	40	5
HWS15	8890	2	.500	8240	2	.500	7600	50	10
HWS18	8890	2	.500	8240	2	.500	7600	50	10
HWS24	21350	2 1/2	.500	15150	2 1/2	.500	14000	63	10
HWS32	21350	2 1/2	.500	15150	2 1/2	.500	14000	63	10

Model	Dimensions (inches)									Approx. weight (lbs)				
										Per inch length			Drives	
	M	N	P	R	S	V	W	Y	SL	BL	T	A1 D2 D2 D3	E1	
HWS5	7/8	2 1/8	1	3/32	3/8	2	#10-24	1 5/8	1 5/8	1 3/4	7/8	7	7 1/4	
HWS7	1 3/4	2 3/4	1 1/2	3/16	5/8	2 7/8	1/4-20	2 3/8	3 1/4	3 7/8	3/16	10	19	
HWS9	1 1/2	2 15/16	1 3/4	3/16	7/8	3 13/16	5/16-18	3 3/4	5	6 1/2	5/16	20	27	
HWS12	1 1/2	3 3/16	1 3/4	3/16	7/8	3 13/16	5/16-18	3 1/4	8 1/8	10 1/2	5/8	38	55	
HWS15	2 1/4	3 1/2	2 3/4	5/16	1 3/8	5 3/8	3/8-16	4 5/8	15	13 3/4	13/16	45	68	
HWS18	2 1/4	3 3/4	2 3/4	5/16	1 3/8	5 3/8	3/8-16	4 5/8	17	19 3/4	1 5/16	102	128	
HWS24	2 1/2	5 9/32	3 3/4	3/8	1 5/8	6 5/8	1/2-13	5 5/8	29 1/8	28 3/4	1 3/4	125	150	
HWS32	2 1/2	6 1/32	3 3/4	3/8	1 5/8	6 5/8	1/2-13	5 5/8	41 1/4	36 3/4	1 3/4	125	-	

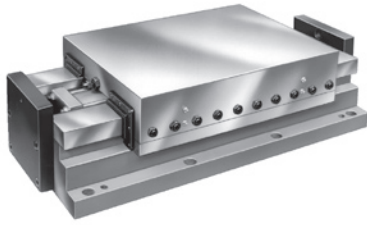

# HWS section

Hydraulic cylinder,  
internal (H4,  
H5, H6, H7)

For dimensions not shown see "HWS" basic assembly on page 8.

**H4**

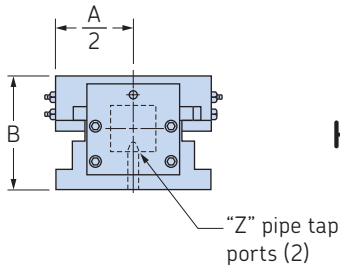
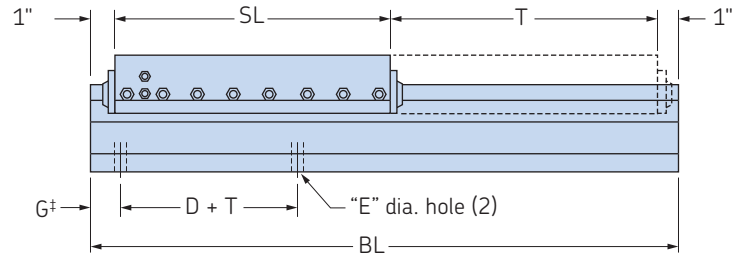

**H5**

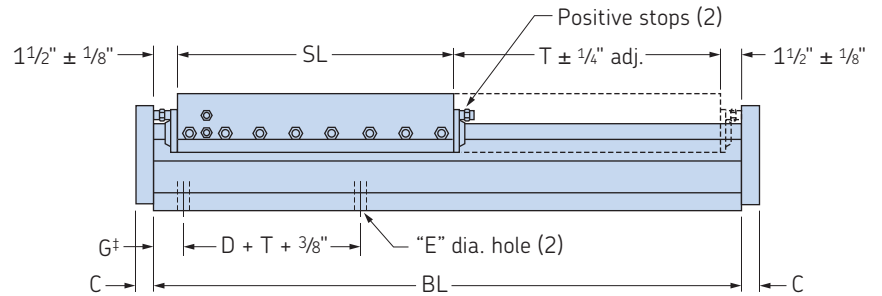

**H6**

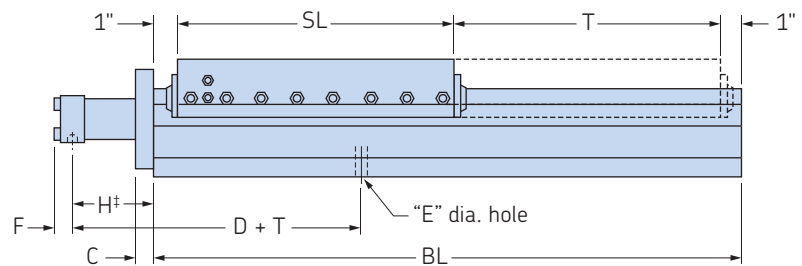

Hydraulic cylinder "X" bore cushioned both ends  
"Y" psi maximum line pressure

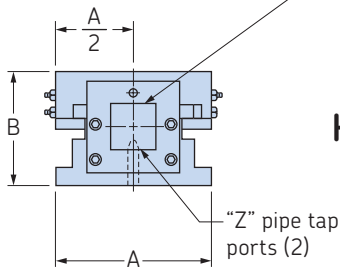

**H7**

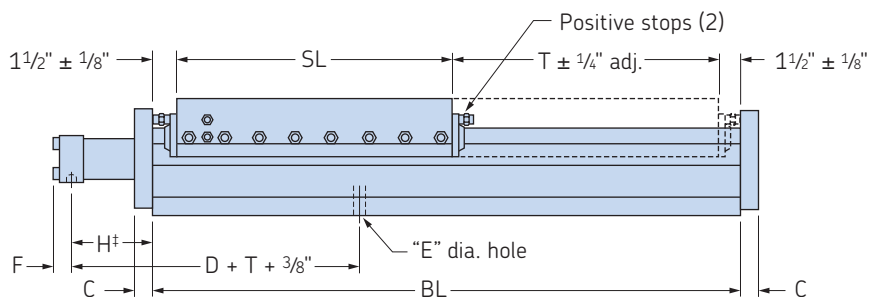

Model	1-inch increments				BL*		Dimensions (inches)										Approx. weight (lbs)				
	SL		T		Min.	Max.	A	B	C	D	E	F	X	Y	Z	Per inch length			Cyl. drive	Stops	
	Min.	Max.	Min.	Max.												SL	BL	T			
HWS7	7	36	2	24	12	72	7	5	1	2 1/4	7/8	13/16	1 1/2	750	3/8-18	3 1/4	3 7/8	3/8	12	5	
HWS9	9	60	2	45	15	84	9	6 3/8	1	2 1/4	7/8	7/8	2	750	3/8-18	5	6 1/2	5/8	19	7	
HWS12	12	60	2	50	18	96	12	7 1/2	1 1/4	2 3/8	7/8	7/8	2 1/2	750	3/8-18	8 3/8	10 1/2	7/8	33	13	
HWS15	15	60	2	55	21	96	15	8 1/2	1 1/4	2 5/8	1	1 1/16	3 1/4	750	1/2-14	11 3/4	15	1	50	17	
HWS18	18	60	2	60	24	120	18	10 1/2	3 1/2	3 3/32	1 1/4	1 9/16	3 1/4	1250	3/4-14	17	19 3/4	2	92	31	
HWS24	24	60	2	70	30	120	24	12	4	3 7/8	1 1/4	1 9/16	4	1250	3/4-14	29 1/8	28 1/4	2 3/4	124	38	

\*See page 8 for base lengths and mounting hole locations.  
†See page 12 for drive selection.

# HWS section

Hydraulic cylinder,  
internal (H4,  
H5, H6, H7)



Slides with hydraulic-cylinder drives mounted internal or partially internal (H6 and H7) are more compact than end-mounted drives shown on page 13. These slides can be used whenever the cylinder size provides sufficient thrust. On H4 and H5 drives, both cylinder ports are accessible through the slide base. On H6 and H7 drives, the front port is accessible through the slide base and the rear port is external to the slide base.

H5 and H7 drives are furnished with an adjustable end stop. The travel can be adjusted  $\pm 1/8$  inch on each end.

The hydraulic cylinder is cushioned on both ends for a smooth stop. Cylinders are of the standard, square-head-medium-pressure type on HWS7 through HWS15 slides and high pressure type on HWS18 and HWS24 slides.

To select the drive that suits your requirements, follow the procedure listed below:

- Select the slide width, "A" dimension.
- Check thrust requirements (see page 6) against the thrust capacity of slide selected using "X" bore and line pressure. Do not exceed the maximum line pressure "Y."
- Determine your needs, adjustable end stop drives (H5 and H7) or drive without stops (H4 and H6).
- Determine saddle length, (SL) travel, (T) and the base length, (BL=SL+T+2) for drives H4 and H6 or (BL=SL+T+3) for drives H5 and H7. If the base does not calculate to a standard length, adjust the saddle length or travel to suit a standard base length.
- Now follow through the six-step procedure listed under "Drive selection" (chart shown below). It may not be necessary to complete all six steps. Proceed until the formulated requirements are met. (Internal cylinder port locations are determined by the "G" dimension, step 1; partially internal cylinder port locations by the "H" dimension, step 4).

For other accessories, see pages 23 and 24.

Model	Drive selection†				1) $G = SL - T - K$ (H4 or H5) 2) $G \geq G \text{ min.}$ , use G calc. in step 1 3) $G < G \text{ min.}$ , calculate H 4) $H = T + K - SL$ (H6 or H7) 5) $H \geq H \text{ min.}$ , use H calc. in step 4 6) $H < H \text{ min.}$ , use H min.
	G	H	K		
	Min.	Min.	H4 H6	H5 H7	
HWS7	2	2	7	$6^{11/16}$	
HWS9	2	2	8	$7^{11/16}$	
HWS12	2	2	9	$8^{11/16}$	
HWS15	2	2	10	$9^{11/16}$	
HWS18	3	3	12	$11^{11/16}$	
HWS24	3	3	14	$13^{11/16}$	

\*H > 2/3T Cylinder furnished with cap-end foot mount; customer to provide support.  
 †See illustrations on page 11.

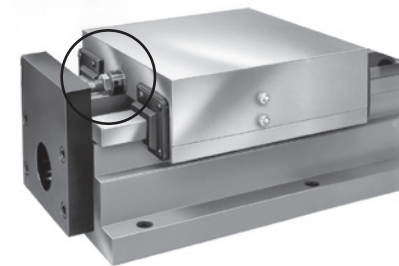

### Micrometer stop accessory

For convenience in adjusting the end stops, a micrometer dial graduated in .001 inch increments is available on H5 and H7 models. The total adjustment is  $\pm 1/8$  inch on each end. (Must be specified when ordering.)

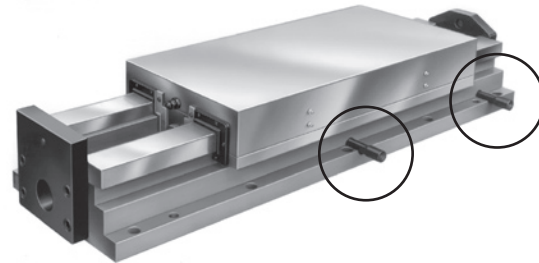

### Side porting accessory

When cylinder ports are not accessible through the bottom of the base, or for ease of piping, hydraulic cylinder slides can be furnished with the ports piped out either side of the base. (Must be specified when ordering.)

Note: "G" or "H" dimension may vary with side and bottom porting.

# HWS section

Hydraulic cylinder, stop rod (H2)

**These slides are used where an even feed rate is required and end limits of travel have to be accurate.**

The hydraulic cylinder is cushioned on both ends for a smooth stop. Cylinders are of the standard, rectangular flange mount, medium pressure type on HWS5 through HWS15 slides and high pressure type on HWS18 through HWS32 slides.

Stops are provided to regulate the length of travel and may be adjusted easily to accommodate different requirements. This feature, when used with a controlled dwell, ensures depth accuracy.

The base length is calculated as follows:  $(BL=C+SL+T+1)$ . If the base does not calculate out to a standard length, adjust the saddle length to suit a standard base length.

For accessories, see pages 23 and 24.

For dimensions not shown, see "HWS" basic assembly on page 8.

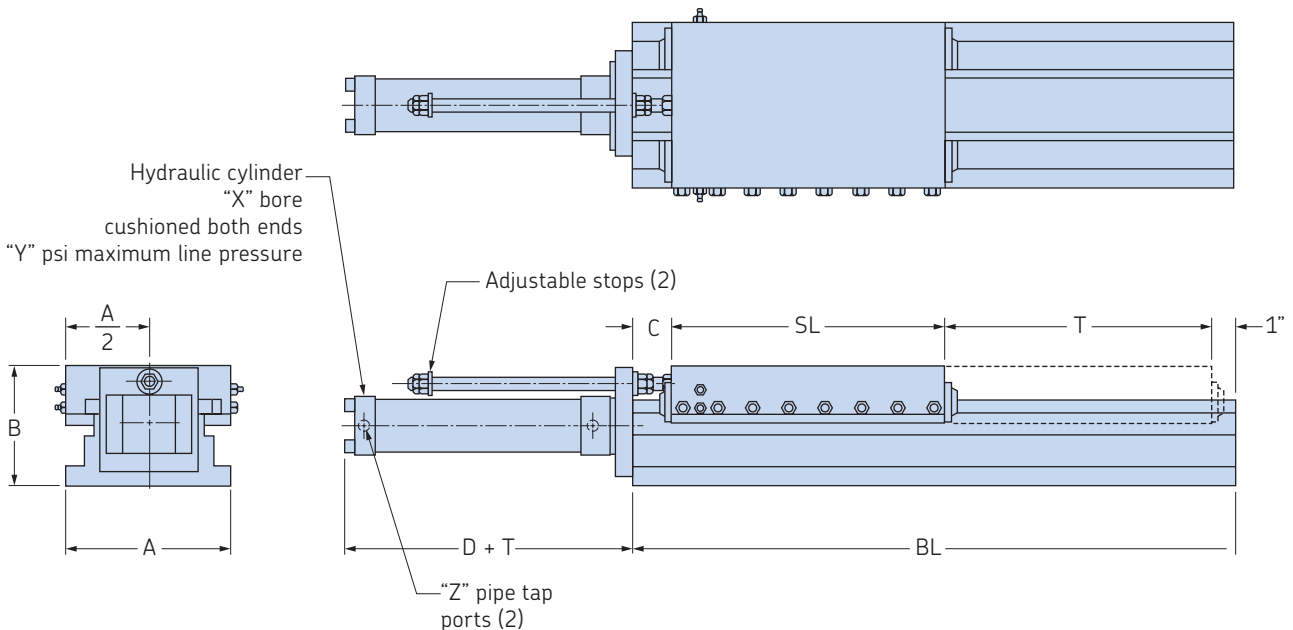
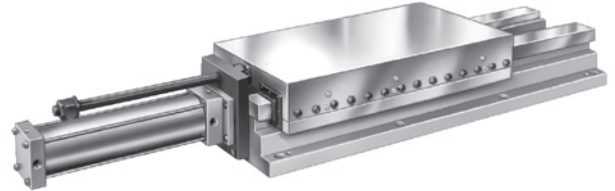

Model	1-inch increments				BL*		Dimensions (inches)							Approx. weight (lbs)			Cyl. drive
	SL		T											Per inch length			
	Min.	Max.	Min.	Max.	Min.	Max.	A	B	C	D	X	Y	Z	SL	BL	T	
HWS5	5	21	2	16	12	24	5	3 1/2	2	5	1 1/2	750	3/8-18	1 5/8	1 3/4	3/8	9
HWS7	7	36	2	30	12	72	7	5	2	5 7/16	2	750	3/8-18	3 3/4	3 7/8	5/8	15
HWS9	9	60	2	30	15	84	9	6 3/8	2	5 9/16	2 1/2	750	3/8-18	5	6 1/2	3/4	22
HWS12	12	60	2	30	18	96	12	7 1/2	2	6 5/8	3 3/4	750	1/2-14	8 3/8	10 1/2	7/8	41
HWS15	15	60	2	36	21	96	15	8 1/2	3	6 5/8	4	750	1/2-14	11 3/4	15	1 1/4	60
HWS18	18	60	2	36	24	120	18	10 1/2	3	8 5/8	4	1250	3/4-14	17	19 3/4	2 7/8	108
HWS24	24	60	2	36	36	120	24	12	4	9 5/8	5	1250	3/4-14	29 1/8	28 1/4	4 1/2	158
HWS32	32	60	2	36	42	120	32	12 1/2	4	10 1/8	5	1250	3/4-14	41 1/4	36 1/4	4 1/2	158

\*See page 8 for base lengths and mounting hole locations.

# HWS section

Air cylinder stop rod (P2), and air cylinder hydraulic-check, stop rod (P4, P5)

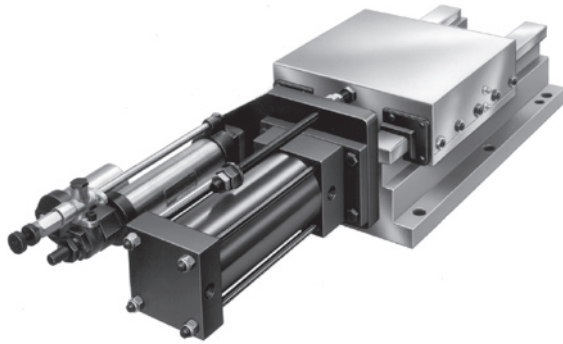

**Air cylinder drive slides are commonly used for light to moderate loads and where end limits of travel have to be accurate.**

P2 drives are used for two-position applications that do not require an even feed rate. P4 parallel mount and P5 in-line mount drives use a hydraulic check with the cylinder to provide a smooth, adjustable rate of feed. P5 not available on HWS5 model.

Forward acting hydraulic checks with a feed rate control of 4 to 300 ipm are standard. Reverse-acting, double-acting, skip, stop or precision (feed rate 1 to 50 ipm) hydraulic checks are available on request.

Adjustable stops are provided to regulate the length of travel. This feature, when used with a controlled dwell, ensures depth accuracy.

The base length is calculated as follows:  $BL=SL+T+3$ . If the base does not calculate out to a standard length, adjust the saddle length or travel to suit a standard base.

For accessories, see pages 23 and 24.

For dimensions not shown, see "HWS" basic assembly on page 8.

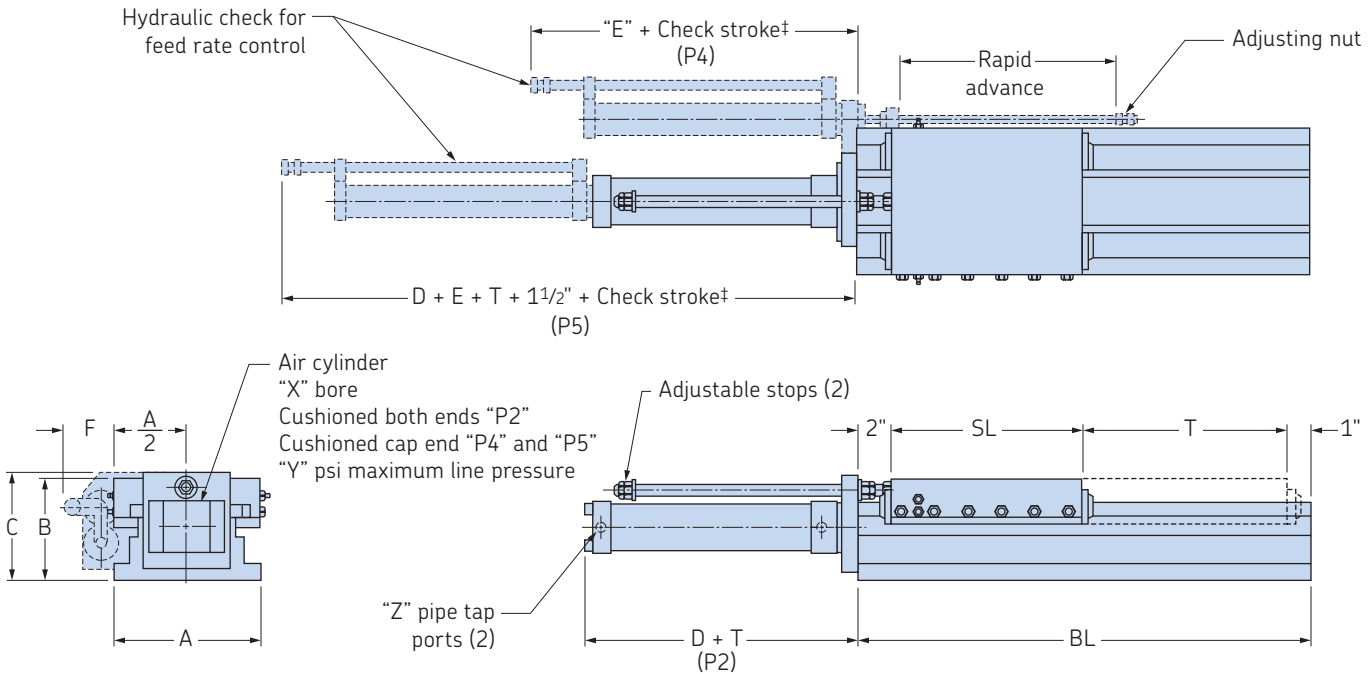

Model	1-inch increments					BL*		Dimensions (inches)										Approx. weight (lbs)			
	SL		T			Min.	Max.	A	B	C	D	E	F	X	Y	Z	Per inch length			Cyl. drive	
	Min.	Max.	Min.	Max.													SL	BL	T		
			P2	P4	P5																
HWS5	5	21	2	16	16	—	12	24	5	3 1/2	3 7/16	4 15/16	9	4 1/16	2	250	3/8-18	1 5/8	1 3/4	3/4	17
HWS7	7	24	2	30	18	9	12	60	7	5	5 7/16	9	4 1/16	2 1/2	250	3/8-18	3 1/4	3 7/8	1	27	
HWS9	9	24	2	30	18	9	15	60	9	6 3/8	6 3/8	6 1/4	9	4 1/16	3 3/4	250	1/2-14	5	6 1/2	1 1/4	39
HWS12	12	30	2	30	18	9	18	72	12	7 1/2	7 1/2	6 1/2	9	4 1/16	4	200	1/2-14	8 1/8	10 1/2	1 1/2	61
HWS15	15	30	2	36	18	9	21	72	15	8 1/2	8 5/8	6 13/16	9	4 1/16	5	150	1/2-14	11 3/4	15	2	89

\*See page 8 for base lengths and mounting hole locations.

†Hydraulic check strokes available in 2, 4, 6, 9, 12, 15, and 18 inches. Check supplied with stroke equal to or greater than travel.

# HWL section

## Low profile basic

HWL basic hardened steel way slide assemblies have a lower profile than the HWS slide assemblies, and are used in applications where space is limited or multiple axis compounds are required. HWL slides reduce the centerline height of spindles and holding fixtures mounted to the saddle, which reduces the moment due to the thrust load.

Saddle lengths are available in 1-inch increments up to 60 inches. Base lengths in 3-inch increments from 12" to 30"; 6-inch increments from 30" to 60"; and 12-inch increments from 60" to 120". Base lengths greater than 120 inches are available in 12-inch increments up to 144 inches maximum. This enables the designer to meet specific travel length requirements, which often means savings in cost and space. The saddle is generally shorter than the base — saddle length plus 2 inches for way wipers, plus the travel, equals the base length (BL=SL+T+2). If the base does not calculate to a standard length, adjust the saddle length to suit a standard base length. Base lengths other than shown are available. The saddle, retainer and gib wear surfaces are lined with low-friction bearing material to reduce sliding friction.

A cavity is machined in the center of the base to provide space for a drive mechanism such as a lead screw or cylinder. HWL7 through HWL24 slides with drives are shown on pages 16 through 20. Consult factory for other special drives to suit your particular applications.

For accessories, see pages 23 and 24.

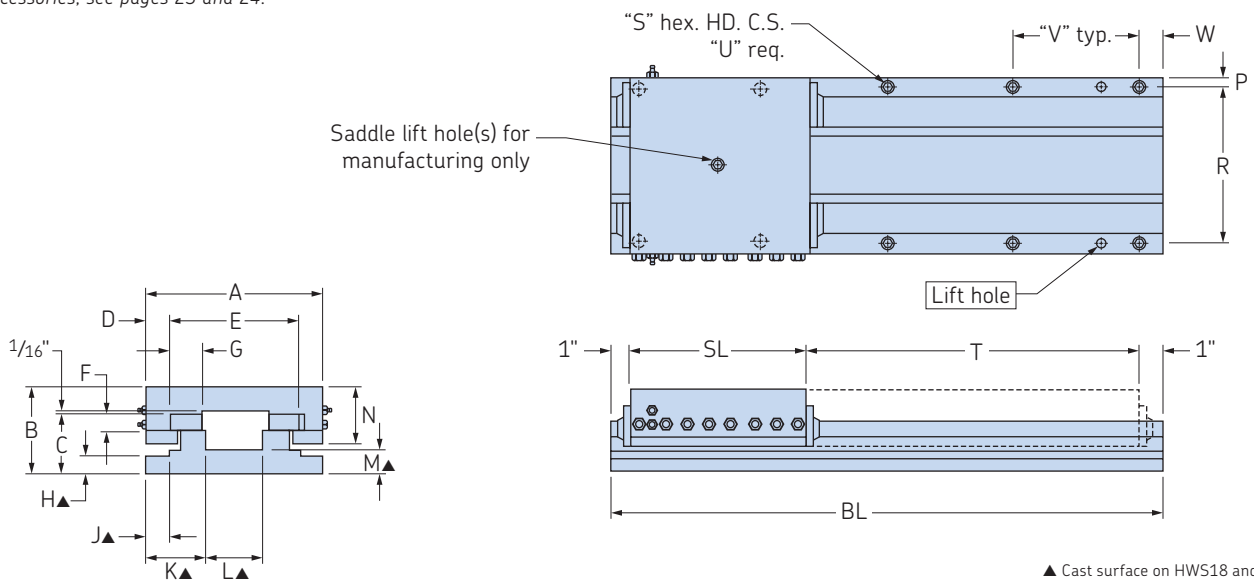
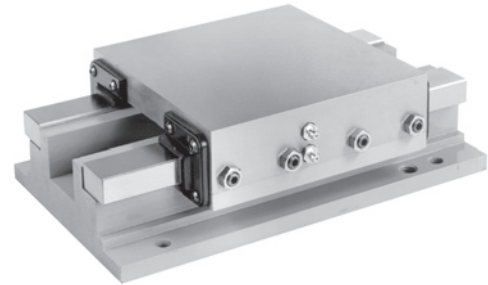

Model	1-inch increments		BL*		Dimensions (inches)																	Approx. weight (lbs) per inch length	
	SL		Min.	Max.	A	B	C	D	E	F	G	H	J	K	L	M	N	P	R	S	SL	BL	
	Min.	Max.																					
HWL7	7	36	12	60	7	3 1/2	2 1/2	15/16	5 1/8	3/4	13/16	1/2	1	2 1/2	2	1	2 1/4	1/2	6	3/8	2 1/2	2 7/8	
HWL9	9	60	12	72	9	4 3/8	3 3/8	1 1/8	6 3/4	3/4	1 3/8	3/4	1	3 3/8	2 1/4	15/16	2 5/8	1/2	8	3/8	3 7/8	4 1/2	
HWL12	12	60	15	84	12	5 1/2	3 15/16	1 1/2	9	1 1/8	2 1/8	7/8	15/16	4 11/16	2 5/8	1 13/16	3 9/16	5/8	10 3/4	1/2	6 3/4	7 3/4	
HWL15	15	60	18	96	15	6 3/4	4 13/16	1 7/8	11 1/4	1 1/2	2 7/8	1	1 9/16	5 7/8	3 1/4	2 3/16	4 7/16	3/4	13 1/2	5/8	10 1/2	12	
HWL18	18	60	21	120	18	8	5 3/4	2 1/4	13 1/2	1 3/4	3 1/4	1 1/4	3 3/16	6 13/16	4 3/8	2 11/16	5 1/4	1 5/8	14 3/4	3/4	14 3/4	16 3/8	
HWL24	24	60	27	120	24	10 1/2	7 1/2	3	18	1 3/4	3 3/4	2 1/8	4	8 1/2	7	2 1/2	6 3/8	2 1/4	19 1/2	3/4	26	27	

\*Base lengths and mounting hole locations — dimensions (inches)

BL	12	15	18	21	24	27	30	36	42	48	54	60	72	84	96	108	120	132	144
U	4	6	6	6	8	8	8	8	8	10	10	10	10	12	12	12	14	16	18
V	9	6	7 1/2	9	7	8	9	11	13	11	12 1/2	14	17	16	18	20	19	18	17
W	1 1/2	1 1/2	1 1/2	1 1/2	1 1/2	1 1/2	1 1/2	1 1/2	1 1/2	2	2	2	2	2	3	4	3	3	4

# HWL section

Hydraulic cylinder, stop rod (H2)

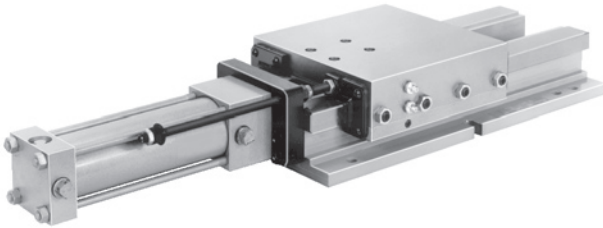

For dimensions not shown, see "HWL" basic assembly on page 15.

**These slides are used where an even feed rate is required and end limits of travel have to be accurate.**

The hydraulic cylinder is cushioned on both ends for a smooth stop. Cylinders are of the standard, medium-pressure type on HWL7 through HWL18 slides and high-pressure type on HWL24 slide.

Stops are provided to regulate the length of travel and may be adjusted easily to accommodate different requirements. This feature, when used with a controlled dwell, ensures depth accuracy.

The base length is calculated as follows:  $BL=C+SL+T+1$ . If the base does not calculate to a standard length, adjust the saddle length to suit a standard base length.

For accessories, see pages 23 and 24.

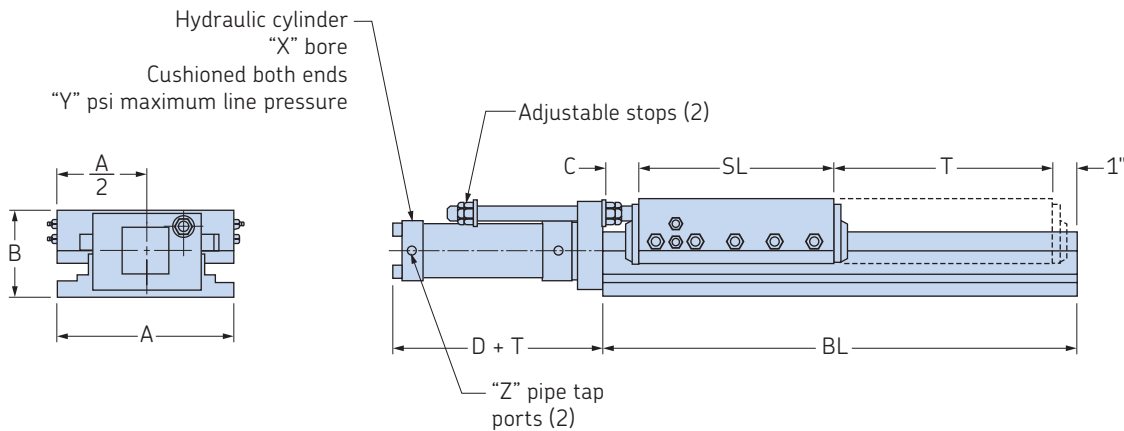
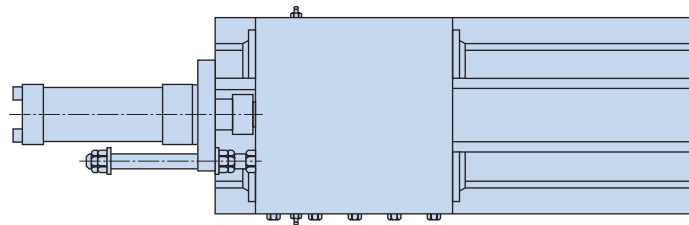

Model	1-inch increments				BL*		Dimensions (inches)							Approx. weight (lbs)			Cyl. drive
	SL		T				A	B	C	D	X	Y	Z	Per inch length			
	Min.	Max.	Min.	Max.	Min.	Max.								SL	BL	T	
HWL7	7	36	2	24	12	60	7	3 1/2	2	5 1/8	1 1/2	750	3/8-18	2 1/2	27 3/8	3/8	9
HWL9	9	60	2	30	15	72	9	4 3/8	2	5 7/16	2	750	3/8-18	3 7/8	4 1/2	5/8	15
HWL12	12	60	2	30	18	84	12	5 1/2	2	5 9/16	2 1/2	750	3/8-18	6 3/4	7 3/4	3/4	22
HWL15	15	60	2	30	21	96	15	6 3/4	2	6 5/8	3 1/4	750	1/2-14	10 1/2	12	7/8	41
HWL18	18	60	2	36	24	120	18	8	3	6 5/8	4	750	1/2-14	14 3/4	16 3/8	1 1/4	60
HWL24	24	60	2	36	30	120	24	10 1/2	3	8 7/8	4	1250	3/4-14	26	27	2 7/8	108

\*See page 15 for base lengths and mounting hole locations.



# HWL section

## Acme lead screw (A1, E1)

Lead screw drives for hardened steel way slides are available in three different drive configurations.

A1 and E1 drives are used primarily for hand positioning and can be furnished with either an in-line drive or a 2:1 reduction, right-angle drive, which can be positioned eight ways as shown below. Please specify position number when ordering. Manual drives are furnished with a balanced handwheel, micrometer dial, needle bearing thrust assembly, an acme lead screw ( $X_1$ ) and bronze nut. Acme adjustable nuts for reducing backlash (.001 inch minimum), or hexagon-end shaft extensions for wrench adjustments are available on request.

The base length is calculated as follows:  $(BL=SL+T+2)$ . If the base does not calculate to a standard length, adjust the saddle length or travel to suit a standard base length.

For accessories, see pages 23 and 24

For dimensions not shown see "HWL" basic assembly page 15.

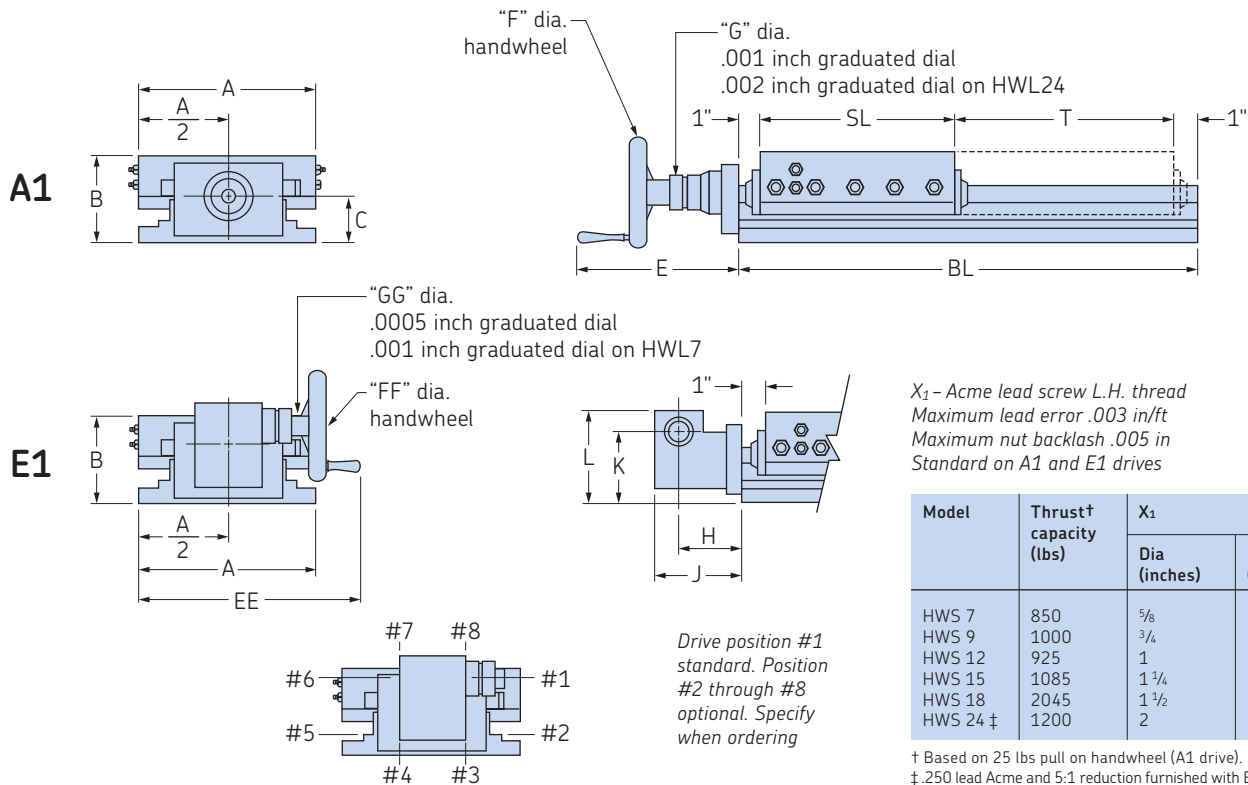
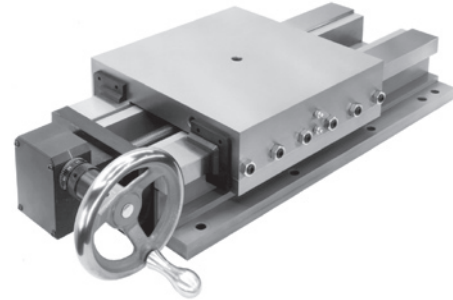

Model	Thrust† capacity (lbs)	$X_1$	
		Dia (inches)	Lead (in/rev)
HWS 7	850	5/8	.100
HWS 9	1000	3/4	.100
HWS 12	925	1	.100
HWS 15	1085	1 1/4	.100
HWS 18	2045	1 1/2	.100
HWS 24 ‡	1200	2	.200

† Based on 25 lbs pull on handwheel (A1 drive).

‡ .250 lead Acme and 5:1 reduction furnished with E1 drive.

Model	1-inch increments				BL*		Dimensions (inches)													
	SL		T				A	B	C	D	E	EE	F	FF	G	GG	H	J	K	L
	Min.	Max.	Min.	*Max.																
HWL7	7	36	1	33	12	60	7	3 1/2	1 29/32	1 13/16	6 3/4	9 3/16	5	4	1 5/8	1	2 9/32	3 1/8	3 1/32	3 29/32
HWL9	9	60	1	34	12	72	9	4 3/8	2 3/8	2 9/32	8 7/8	11 1/8	6	5	2 1/4	1 5/8	3 3/8	4 9/16	3 7/8	5 3/32
HWL12	12	60	1	40	15	84	12	5 1/2	2 29/32	2 15/16	8 7/8	12 5/8	6	5	2 1/4	1 5/8	3 3/8	4 9/16	4 13/32	5 9/16
HWL15	15	60	1	52	18	96	15	6 3/4	3 5/8	3 9/16	9 3/8	15 11/16	7	6	2 1/4	1 5/8	3 5/8	4 13/16	5 1/8	6 9/32
HWL18	18	60	1	59	21	120	18	8	4 5/8	4 5/16	12 3/8	20 7/16	12	9	3	2 1/4	4 27/32	6 5/8	6 7/8	8 1/2
HWL24 ‡	24	60	1	99	27	120	24	10 1/2	6	5 5/8	14 1/8	24 3/8	14	12	4	3	7 1/8	9 5/16	9	10 5/8

\*Maximum travel based on 350 ipm saddle traverse.

\*See page 15 for base lengths and mounting hole locations.

‡ .250 lead Acme and 5:1 reduction furnished with E1 drive.

# HWL section

Ball lead screw  
(D1, D2, D3,  
M1, M2, M3)

The D1, D2 and D3 drives are used for powered applications where the purchaser provides and mounts the driving source. These slides are equipped with a ball lead screw. Each slide has a thrust assembly, which uses a pair of preloaded ball bearings. D1 and M1 feature a rolled ball screw with non-preloaded ball nut. D2 and M2 inch or D3 and M3 metric feature a precision ground ball screw with preloaded ball nut. Preselected ball nuts with .005-inch-maximum backlash are available on request for the D1 and M1 drive assembly. It is highly recommended that all ball screws are protected from contaminants or accidental damage from tools or work pieces.

Total lost motion of slide drive assembly includes backlash in nut, backlash in thrust assembly and deflection in the system due to load. Please consult the factory in applications where positioning is critical.

Please specify maximum traverse rate when ordering. Saddle in (ipm) or ball screw in (rpm).

For accessories, see pages 12, 23 and 24.

For dimensions not shown, see "HWL" basic assembly page 15.

## D1, M1 – Rolled ball lead screw R.H. thread

Maximum lead error .009 in/ft

Maximum nut backlash .010 –.015 inch depending on screw size.

## D2, M2 – Ground ball lead screw R.H. thread

Maximum lead error .0005 in/ft

Zero nut backlash.

## D3, M3 – Ground metric ball lead screw R.H. thread

Maximum lead error .04 mm/m (.0005 in/ft)

Zero nut backlash.

## M1, M2, M3 – Motor mount for customer-supplied motor.

Consult factory for specifications.

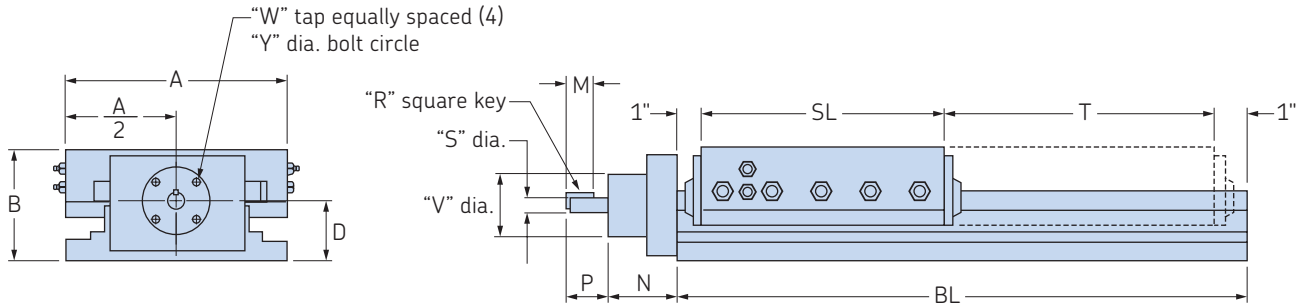

Model	D1, M1			D2, M2			D3, M3		
	Thrust capacity (lbs)	Dia. (inches)	Lead (in/rev)	Thrust capacity (lbs)	Dia. (inches)	Lead (in/rev)	Thrust capacity (lbs)	Dia. (mm)	Lead (mm/rev)
HWL7	740	5/8	.200	—	—	—	—	—	—
HWL9	950	3/4	.200	1435	3/4	.200	1435	20	5
HWL12	2820	1	.250	2280	1	.250	2280	25	5
HWL15	3110	1 1/2	.250	2790	1 1/4	.250	2580	32	5
HWL18	3110	1 1/2	.250	3110	1 1/2	.250	2810	40	5
HWL24	8890	2	.500	8240	2	.500	7600	50	10

Model	Dimensions (inches)									Approx. weight (lbs)				
	M	N	P	R	S	V	W	Y	Per inch length			Drives		
									SL	BL	T	A1 D2 D3	E1	
HWL7	7/8	2 1/8	1	3/32	3/8	2	#10-24	1 5/8	2 1/2	2 7/8	1/8	7	7 1/4	
HWL9	1	2 3/4	1 1/4	1/8	1/2	2 7/8	1/4-20	2 3/8	3 7/8	4 1/2	3/16	10	19	
HWL12	1 1/4	2 3/4	1 1/2	3/16	5/8	2 7/8	1/4-20	2 3/8	6 3/4	7 3/4	5/16	10	19	
HWL15	1 1/2	3 3/16	1 3/4	3/16	7/8	3 13/16	5/16-18	3 1/4	10 1/2	12	5/8	20	27	
HWL18	1 1/2	3 3/16	1 3/4	3/16	7/8	3 13/16	5/16-18	3 1/4	14 3/4	16 3/8	13/16	45	68	
HWL24	2 1/4	3 1/2	2 3/4	5/16	1 3/8	5 3/8	3/8-16	4 5/8	26	27	1 5/16	102	128	

# HWL section

Hydraulic cylinder, adjustable end stops (H3)

These slides have hydraulic-cylinder drives end-mounted. The hydraulic cylinder is cushioned on both ends for a smooth stop. Cylinders are of the standard rectangular-flange mount medium-pressure type on HWL7 through HWL18 slides and high-pressure type on HWL24 slide. An adjustable, positive stop is furnished at each end of saddle that can be adjusted + 1/8 inch on each end to regulate the length of travel.

The base length is calculated as follows: (BL=SL+T+3). If the base does not calculate to a standard length, adjust the saddle length or travel to suit a standard base.

For accessories, see pages 23 and 24.

For dimensions not shown, see "HWL" basic assembly page 15.

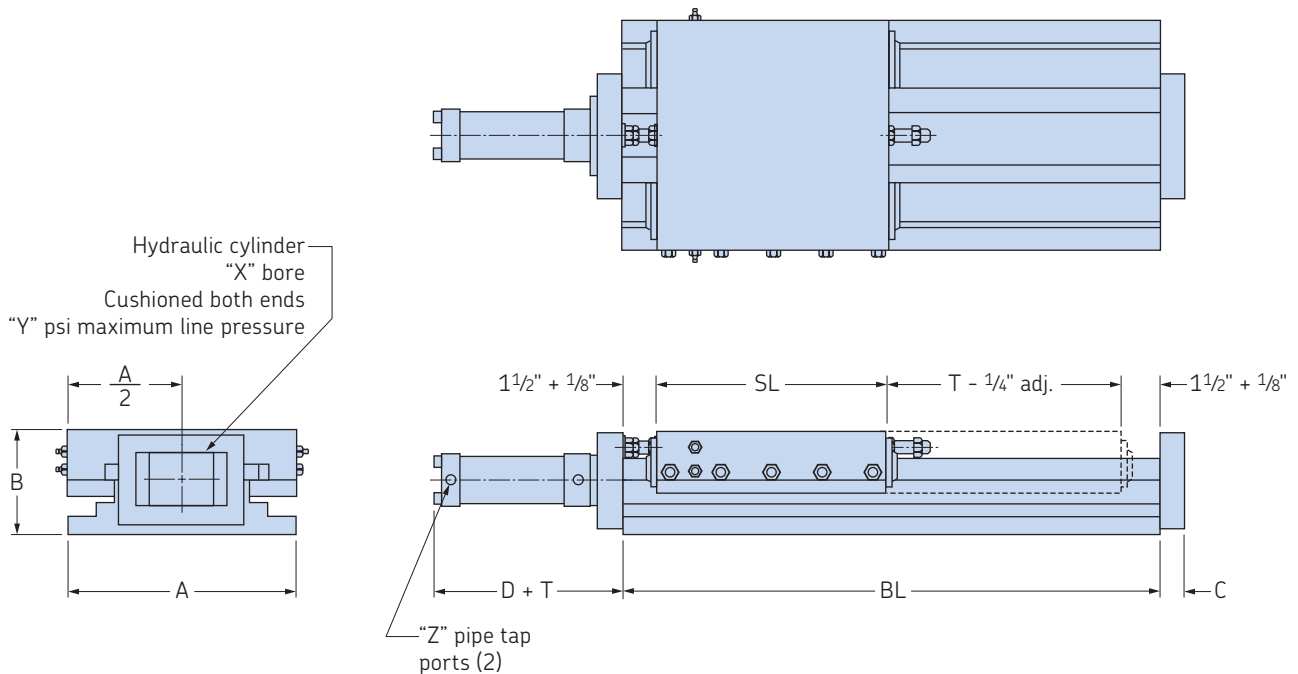

Model	1-inch increments				BL*		Dimensions (inches)							Approx. weight (lbs)			Cyl. drive
	SL		T											Per inch length			
	Min.	Max.	Min.	Max.	Min.	Max.	A	B	C	D	X	Y	Z	SL	BL	T	
HWL7	7	36	2	24	12	60	7	3 1/2	3/4	5 1/8	1 1/2	750	3/8-18	2 1/2	2 7/8	3/8	9
HWL9	9	60	2	30	15	72	9	4 3/8	1	5 7/16	2	750	3/8-18	3 7/8	4 1/2	5/8	15
HWL12	12	60	2	30	18	84	12	5 1/2	1	5 9/16	2 1/2	750	3/8-18	6 3/4	7 3/4	3/4	22
HWL15	15	60	2	30	21	96	15	6 3/4	1 1/4	6 5/8	3 1/4	750	1/2-14	10 1/2	12	7/8	41
HWL18	18	60	2	36	24	120	18	8	1 1/4	6 5/8	4	750	1/2-14	14 3/4	16 3/8	1 1/4	60
HWL24	24	60	2	36	36	120	24	10 1/2	3 1/2	8 7/8	4	1200	1/2-14	26	27	2 7/8	108

\*See page 15 for base lengths and mounting hole locations.

# HWL section

Air cylinder stop rod (P2), and air cylinder hydraulic-check, stop rod (P4, P5)

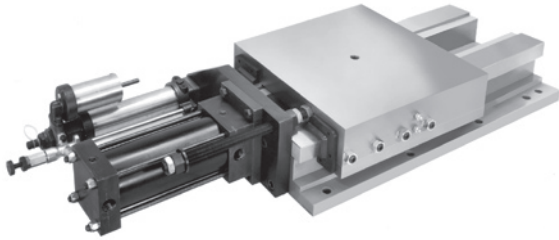

Air cylinder drive slides are commonly used for *light to moderate loads* and where end limits of travel have to be accurate.

P2 drives are used for two-position applications that do not require an even feed rate. P4 parallel-mount and P5 in-line-mount drives use a hydraulic check with the cylinder to provide a smooth, adjustable rate of feed. P5 not available on HWL7 model.

Forward acting hydraulic checks with a feed rate control of 4 to 300 ipm are standard. Reverse-acting, double-acting, skip, stop or precision (feed rate 1 to 50 ipm) hydraulic checks are available on request.

Adjustable stops are provided to regulate the length of travel. This feature, when used with a controlled dwell, ensures depth accuracy.

The base length is calculated as follows:  $BL=SL+T+3$ . If the base does not calculate to a standard length, adjust the saddle length or travel to suit a standard base.

For accessories, see pages 23 and 24.

For dimensions not shown, see "HWL" basic assembly page 15.

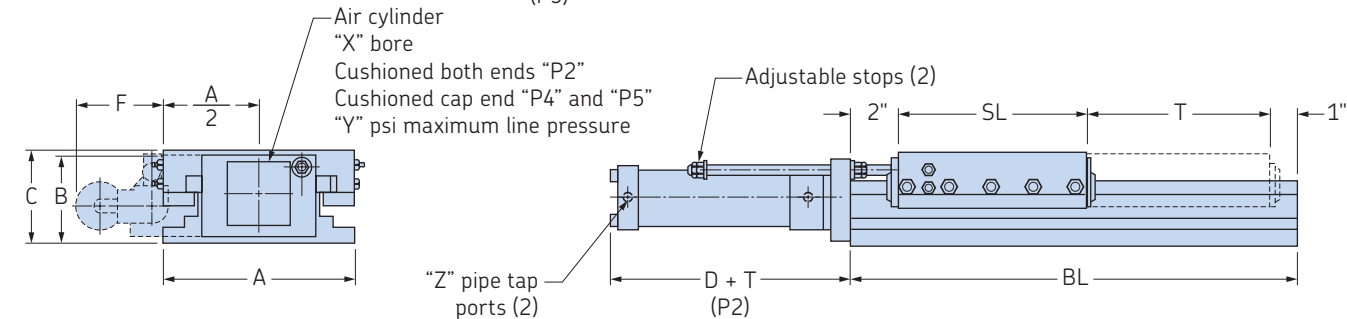
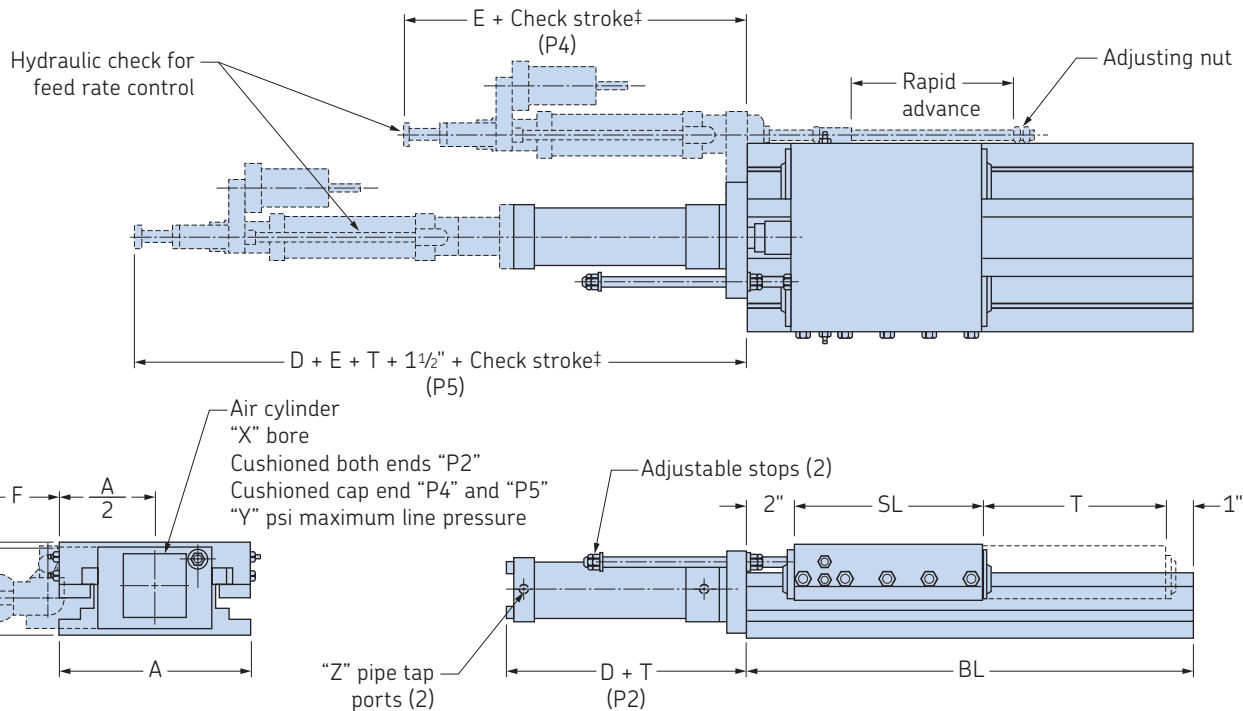

Model	1-inch increments					BL*		Dimensions (inches)										Approx. weight (lbs)			Cyl. drive
	SL		T			Min.	Max.	A	B	C	D	E	F	X	Y	Z	Per inch length				
	Min.	Max.	Min.	Max.													SL	BL	T		
			P2	P4	P5																
HWL7	7	24	2	24	18	—	12	60	7	3 1/2	3 7/8	4 15/16	9	4 1/16	2	250	3/8-18	2 1/2	2 7/8	3/4	17
HWL9	9	24	2	30	18	9	15	72	9	4 3/8	4 3/8	5 7/16	9	4 1/16	2 1/2	250	3/8-18	3 7/8	4 1/2	1	27
HWL12	12	30	2	30	18	9	18	84	12	5 1/2	5 1/2	6 1/4	9	4 1/16	3 3/4	250	1/2-14	6 3/4	7 3/4	1 1/4	39
HWL15	15	30	2	30	18	9	21	96	15	6 3/4	6 3/4	6 1/2	9	4 1/16	4	200	1/2-14	10 1/2	12	1 1/2	61

\*See page 15 for base lengths and mounting hole locations.

† Hydraulic check strokes available in 2, 4, 6, 9, 12, 15 and 18 inches. Check supplied with stroke equal to or greater than travel.

**Special**  
Hardened steel way  
slide modules



**18054 – 3500/HWL7/HWS7/HWL12 special compound slide and spindle module**

Hydraulic-driven slides for three axes of motion. Travels in X-axis: 3", Y-axis: 4", Z-axis: 6". *Application: Plunge mill two pads on an aluminum part.*

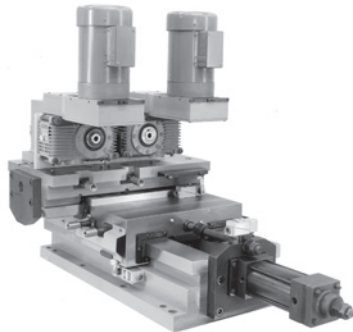

**17526 – Special compound slide and spindle module**

Lower slide is a three-position type. End-mounted hydraulic cylinder has a double rod with one end used as an in-line adjustable positive stop. Hydraulic cylinder mounted under the saddle extends the balance of the travel, using the stop rod assembly for positive depth control. Upper slide has an internal-mounted cylinder assembly. Mounted on the saddle are two 4000-belt, gear-driven spindle assemblies. *Application: Advance lower slide to center position, cross feed upper slide to mill face of two parts. Feed lower slide to hollow mill same two parts. Retract lower slide to starting position, retract cross feed slide and index parts.*

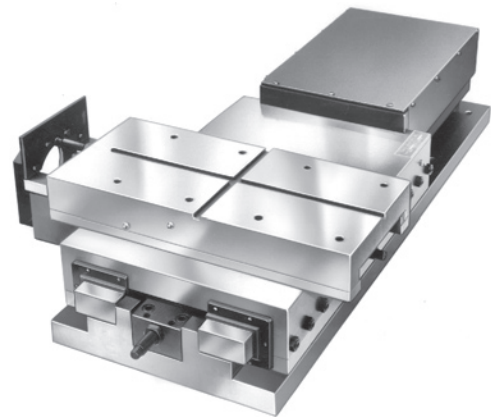

**17590 – HWL9/HWL15 special compound slide module**

Lower slide assembly is designed to accept a ball screw and nut assembly. Upper slide assembly is designed for a hydraulic cylinder with adjustable forward stop. On this module the customer will furnish the power drive assemblies. *Application: Facing and boring.*



**17576 – HWS15 special compound slide module**

Both axes are supplied with ground ball screw and nut assemblies to be motorized. Lower axis used for positioning. Upper axis has a R.H. and L.H. ground ball screw so the saddles can be moved toward and away from each other. *Application: Compound slide assembly for special lathe.*

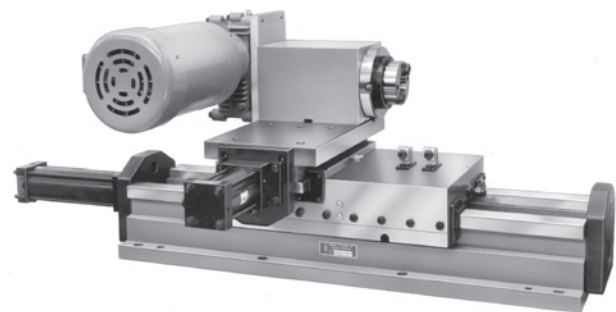

**17572 – HWS9/HWS12 special compound slide and spindle module**

Both slide axes are hydraulic-cylinder-powered. Lower axis used for three positions. Upper slide rapid traverse feed, to a depth stop and retract. Spindle is a 4000-series, special-gear drive. *Application: Three position slot milling.*

# Special

Hardened steel way  
slide modules

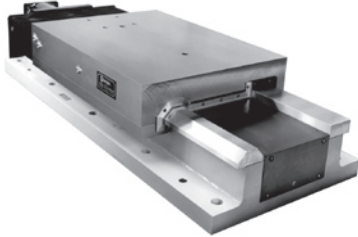

## 18055 - HWV24 special V-type hardened steel way slide

Ideally suited for your precision boring applications. Available in sizes 7" to 24".

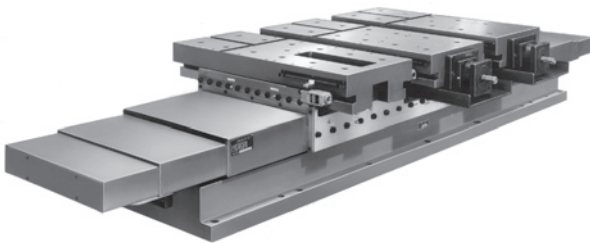

## 17559 - HWL15/HWS24 compound slide module

Lower slide is equipped with ball screw and nut assemblies to be motorized and programmed for three stops. The saddle has hydraulic retainer locks to secure the positions. Three HWL15 slides are machined in the saddle, two of which are supplied with ball screw and nut assemblies, the other to be lead screw powered and gear driven from customer's tapping head. *Application: Drilling, chamfering and tapping of stationary part.*



## 17728 - 8000C-X3M-50-G-D3 special motorized vertical travel spindle mounted to HWS32/HWS32

Travels in Z-axis: 20", X-axis: 12", Y-axis: 28". Precision ground screws and preloaded nuts — all axes. 15 H.P. spindle drive with two-speed manual transmission. *Application: Three-axis machining with customer-engineered and assembled CNC control.*

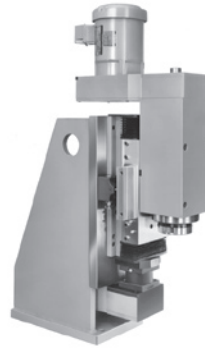

## 17644 - HWS7/4000 special slide and spindle module

Slide has DC motorized belt-driven ball screw assembly. Spindle nose end designed for special boring tool holder. Spindle belt-driven with AC motor and electronic variable speed controls. Slide is supplied with accordion way covers, multiple limit switch assembly and a welded steel angle bracket. *Application: Precision boring of parts on dial boring machine.*

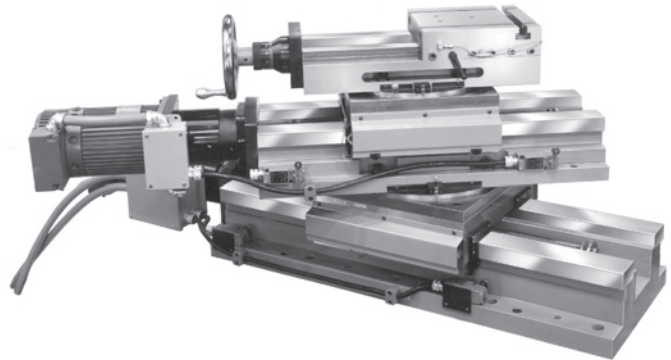

## 17726 - DC12/HWS15/HWS18 with rotational sub-plates

Special three-axis assembly, complete with programmable controller capable of two-axis simultaneous operation. Travels in HWS18 axis: 28", HWS15 axis: 19", DC12 axis: 12", with precision ground ball screws and preloaded nuts in both hardened way axes. *Application: Special lathe compound for turbine machining.*

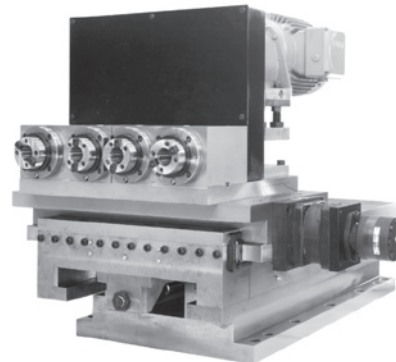

## 17632 - HWS24/HWL20/4000 special slide and spindle module

Lower axis slide has internal mounted hydraulic cylinder assembly. Top slide is a low profile base with ball-screw assembly and hydraulic-drive motor. Four spindles are in a cluster, each pair driven by an electric gear motor. *Application: Milling four separate surfaces of a piece part at one time.*

# Accessories

- 1 Limit switch-side mounted:** Heavy-duty, oil-tight, plug-in limit switches are offered in four commonly used arrangements and are available on all model slides. Other types of switch arrangements can be supplied depending on your control requirements. Switch mounting configurations are shown for models HWS and HWL slides.

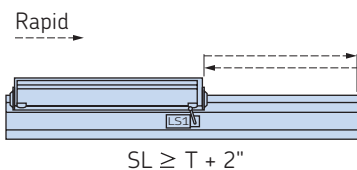
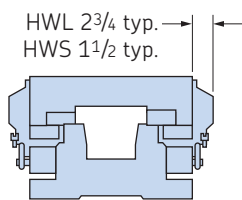
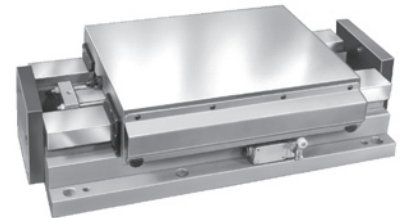

**SA1** – One neutral position switch for signal at each end of travel. Saddle lengths greater or equal to the travel plus 2 inches.

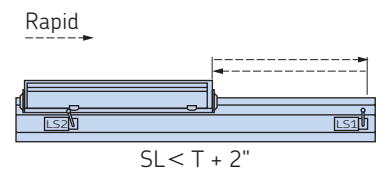

**SA2** – Two standard switches for signal at each end of travel. Saddle lengths less than the travel plus 2 inches.

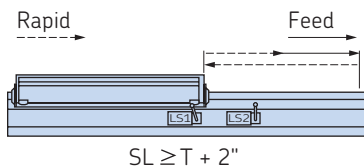

**SA3** – One neutral position switch for signal at each end of travel and one standard switch to signal a portion of travel in feed (specify feed length). Saddle lengths greater or equal to the travel plus 2 inches.

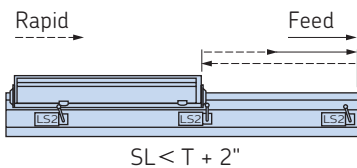

**SA4** – Three standard switches. Two used for signal at each end of travel and one used to signal a portion of travel in feed (specify feed length). Saddle lengths less than the travel plus 2 inches.

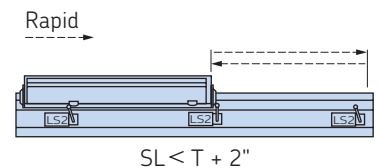

**SA5** – Three standard switches. Two used for signal at each end of travel and one used for home position.

- 2 Limit switch-side mounted multiple:** Precision multiple limit switches are more compact in design and combine from two to six switches in one housing. They are most beneficial when space is limited or for numerous switching positions. Available on all model slides.

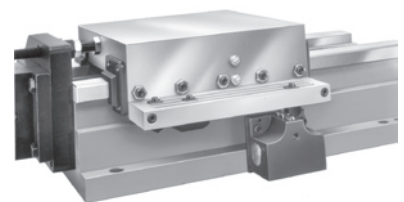

- 3 Limit switch-stop rod:** A heavy-duty, oil-tight, plug-in neutral position switch gives a signal at each end of the travel and does not require resetting when the travel limits are adjusted. Available on all stop rod model slides.

- 4 Lubrication system-manual or automatic:** Either system provides a convenient method of supplying a metered quantity of oil to the slide assembly with the inherent advantages of safety, cleanliness and savings both in time and lubricant. The manual system uses a pull handle pump lubricator, while the automatic system uses an electric pump that can be set to provide proper lubrication. Either lubrication system can be supplied with nylon tubing, steel tubing or an internal manifold in the saddle (please specify). The lubricator will be supplied unmounted with six feet of nylon tubing.

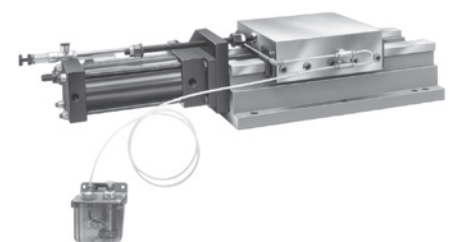

# Accessories

**5 Way covers-accordion:** When way wipers are not adequate, coated fabric covers are recommended in applications where there are chips, dirt or dust that might harm the way surface or drive mechanism in the base cavity. *These covers are not available on end stop models or cylinder end of stop rod models.*

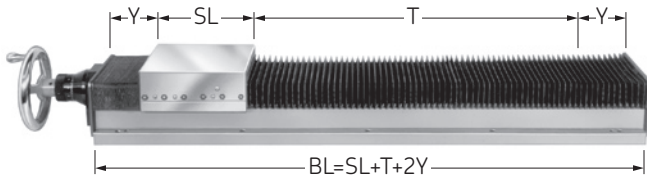

Slide width	Dimensions (inches)	
	T Max.	Y*
5	15	.133T + .47
7	20	.098T + .36
9	25	.098T + .36
12	30	.079T + .36
15	40	.098T + .36
18	50	.044T + .36
24	70	.036T + .36
32	70	.036T + .36

\*Round up to 1/2" increment, Y min. = 1".



**6 Way covers-telescoping:** Collapsible metal covers with durable wipers and guides protect the ways and drive mechanism from contaminants such as chips and dirt. These covers also prevent accidental damage from tools or work pieces. The covers are fixed to the saddle and base support bracket. They are available on all model slides except drive end on models A1 and E1. Consult factory for specific dimensions.

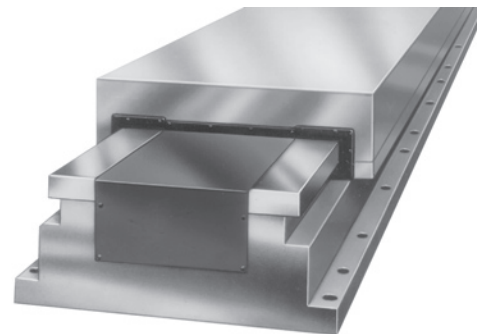

**7 Cavity cover-fixed:** A metal cover mounted between the ways and fixed to the base, with a durable wiper mounted to the saddle protects the drive mechanism against chips, dirt, dust or accidental damage from tools or work pieces. These covers are generally used for short travel slides, and their use depends on the saddle length and travel. Available on all slides. Consult factory if applicable to your particular slide configuration.

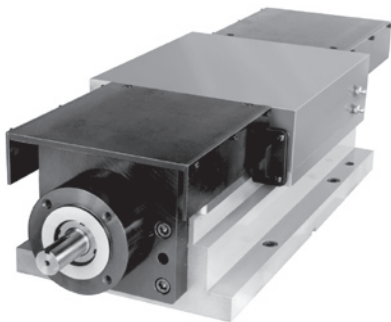

**8 Way covers-fixed:** A metal cover with two side plates fixed to the saddle provides protection to the ways and base cavity from contaminants such as chips, dirt or accidental damage from tools or workpieces. These covers are generally used for short travel slides. Available on all slides except drive end on models A1, E1, P4 and P5.

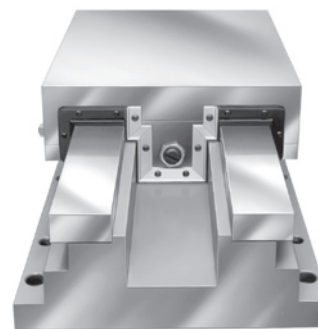

**9 Cavity wiper:** A durable wiper mounted to the saddle (opposite the drive end) wipes away chips, dirt and other contaminants from the base cavity. Base or end plate holes may be necessary for chip removal. Cavity wipers are available on all model slides with drives that do not extend beyond the front end of the saddle.



# Idea bulletins

## To equip the world with SKF knowledge

The following pages contain applications companies have used to solve manufacturing challenges. SKF Precision Technologies rises to the occasion every time, to provide technical consultation and expertise. Whatever the requirements, SKF Precision Technologies can meet industry needs while working to the highest standards worldwide. Don't believe it? Visit the Grafton, Wisc., plant and you will see firsthand, the facility where SKF precision slides are born.

### No. 2008:

Rigidity of vertical travel improved for faster feed rates..... 26, 27

### No. 2009:

Motorized spindles finish wrist-pin bores to perfection ..... 28, 29

### No. 2014:

Upstream design and continuous operation save setup time..... 30, 31

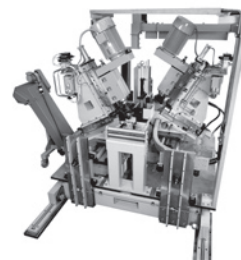
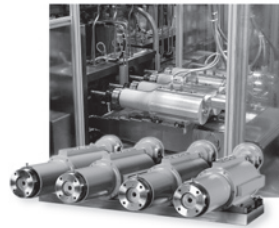
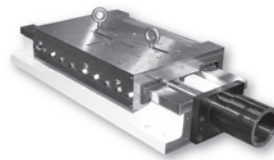

# Idea bulletin

## High-speed, dual-spindle, multi-axis boring machine

### Rigidity of vertical travel improved for faster feed rates

#### Application

An American motorcycle manufacturer was gearing up for increased production of their large touring motorcycles. Operations required on this dual spindle multi-axis boring machine were center drill and spot face for the first spindle and 1-1/2" boring operations for the second spindle. The material being worked was Timken cast iron.

#### Challenge

Because the existing 10-year-old dual spindle drilling and boring machine could not keep up with required production rates, the manufacturer decided to replace it. Among the highest priorities for the replacement machine was a design with more vertical rigidity to allow for faster feed rates and shorter cycle times.

#### Solution

Through a joint development process including the manufacturer, the machine tool builder and SKF, a unit was designed that met all of the end-use requirements. The base chosen was a hardened steel way slide with preloaded ground ball screw driven by a single phase motor.

A vertical angle bracket supports another hardened steel way slide with a preloaded ground ball screw driven by a single-phase motor. Spindles chosen were all SKF Precision Technologies model 6500B with a block housing and triplex ball nose bearing arrangement and labyrinth seal. The shaft nose was 50 NMTB taper. The design retained the single motor drive. The customer-supplied reduction unit turns the first spindle at 2,900 rpm and the second spindle at 1,950 rpm.

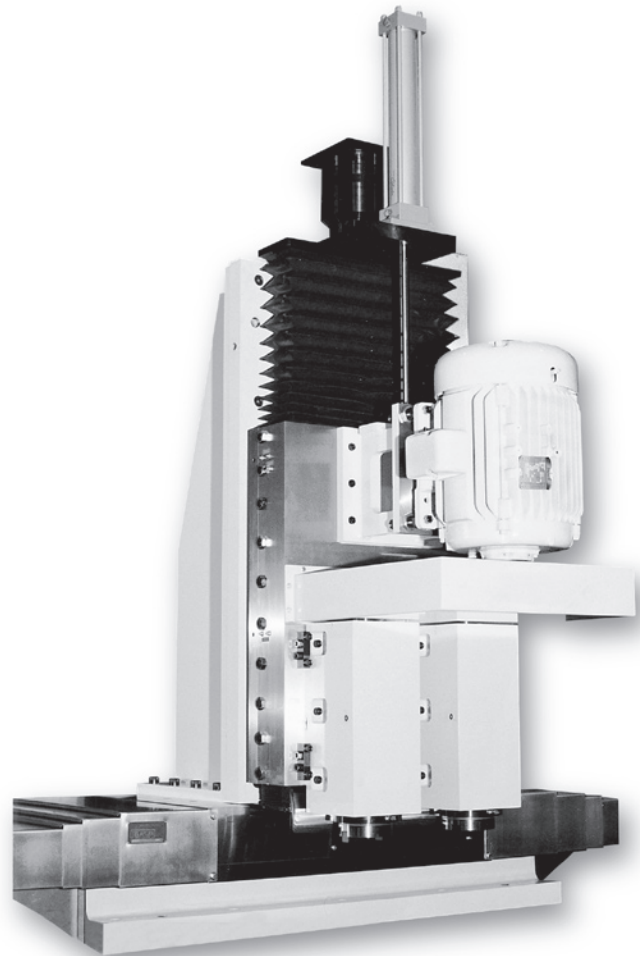

*Custom-designed boring machine with more vertical rigidity to allow for faster feed rates and shorter cycle times.*

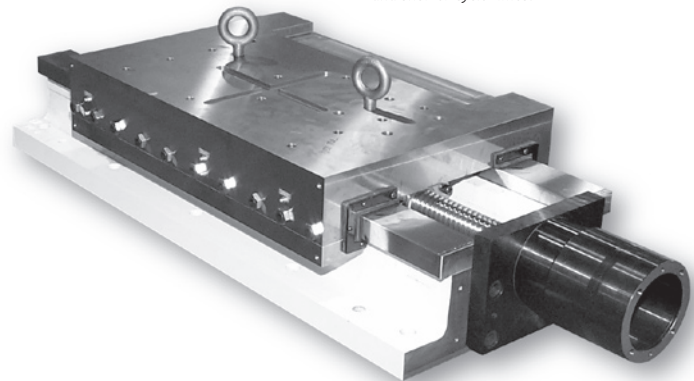

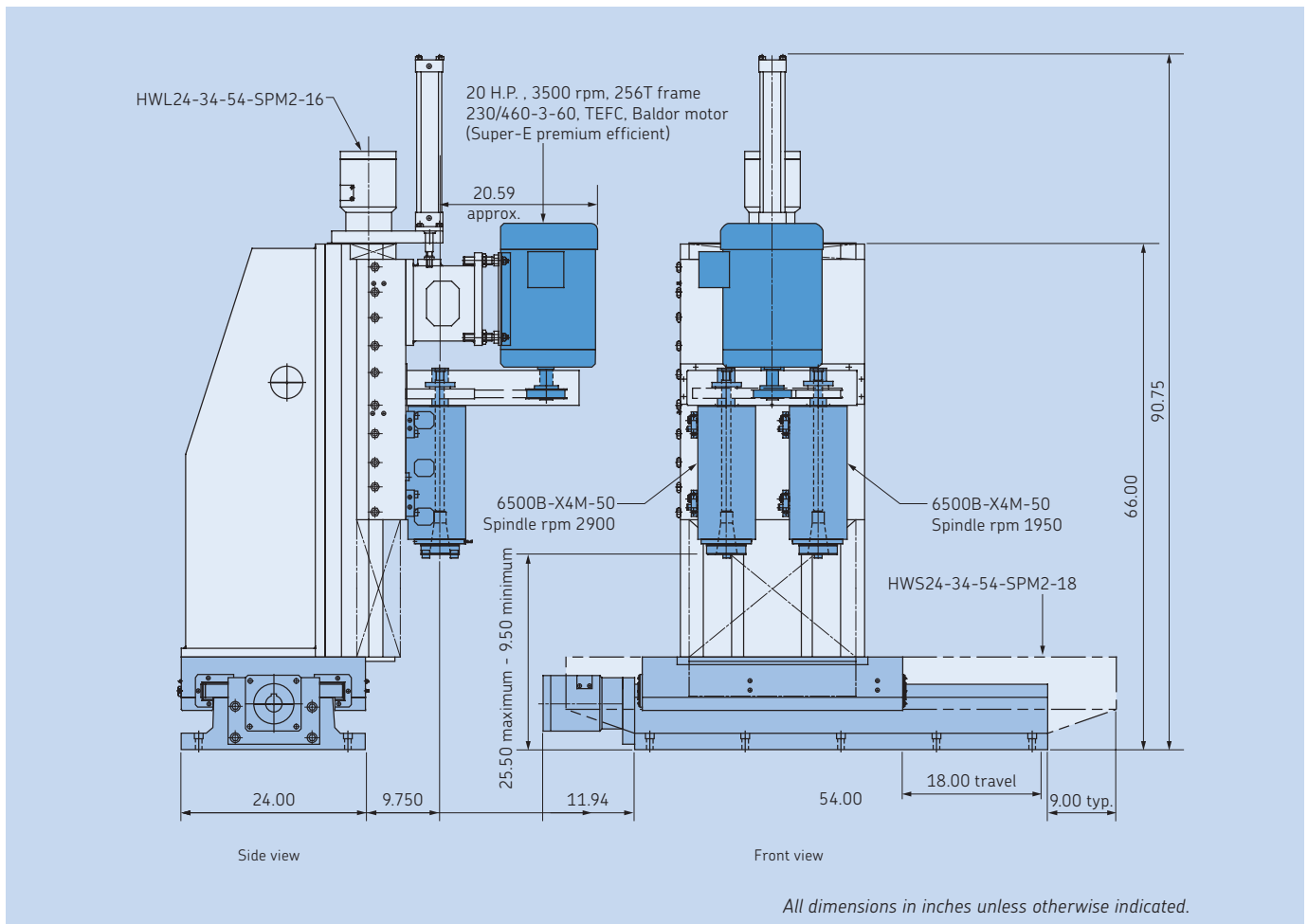

### Cost savings

Factoring in increased production, the machine investment is predicted to begin returning dividends in 18 months. The rugged design has a safety factor of 1.5 of current capacity and allows for future improvements in tooling and new materials.

### Time line

This was a very short delivery schedule; total time from initial concepts to cutting was 14 weeks.

### Technical specifications

#### 6500B spindle:

- Preloaded triplex set, ABEC 7, 15° angular contact ball bearings, medium preload 85mm I.D., nose end. Preloaded pair, ABEC 7, 15° angular contact ball bearings, medium preload 70mm I.D., drive end
- Synthetic grease lubrication
- Labyrinth seal each end
- Maximum thrust into spindle 1,695 lbs
- Shaft supplied with coolant union pilot and threads
- Air purge fitting

#### HWS24-34-54-SPM2-18 slide:

- L.H. gib
- Telescoping steel way covers both ends
- 2.500-.500 R.H. thread ground ball screw - preloaded nut, 1,420 inch-lbs maximum input torque, 350 ipm maximum traverse rate
- Saddle width 24"
- Saddle length 34"
- Base length 54"
- Travel 18"

#### HWL24-34-54-SPM2-16 slide:

- Accordion way covers drive end
- Steel plated accordion way covers opposite drive end
- 2.000-.500 R.H. thread ground ball screw - preloaded nut, 770 inch-lbs maximum input torque, 350 ipm maximum traverse rate
- Saddle width 24"
- Saddle length 34"
- Base length 54"
- Travel 16"

# Idea bulletin

## GLS120 integrally motorized spindles mounted on a hardened way slide

### Motorized spindles finish wrist-pin bores to perfection

#### Application

A transfer line processing automotive engine pistons in groups of four required a compact finishing station for the wrist-pin bore. While the machining done at the station would be light, the location accuracy, inside diameter dimension and surface finish quality had to be “dead on” when the parts left the station.

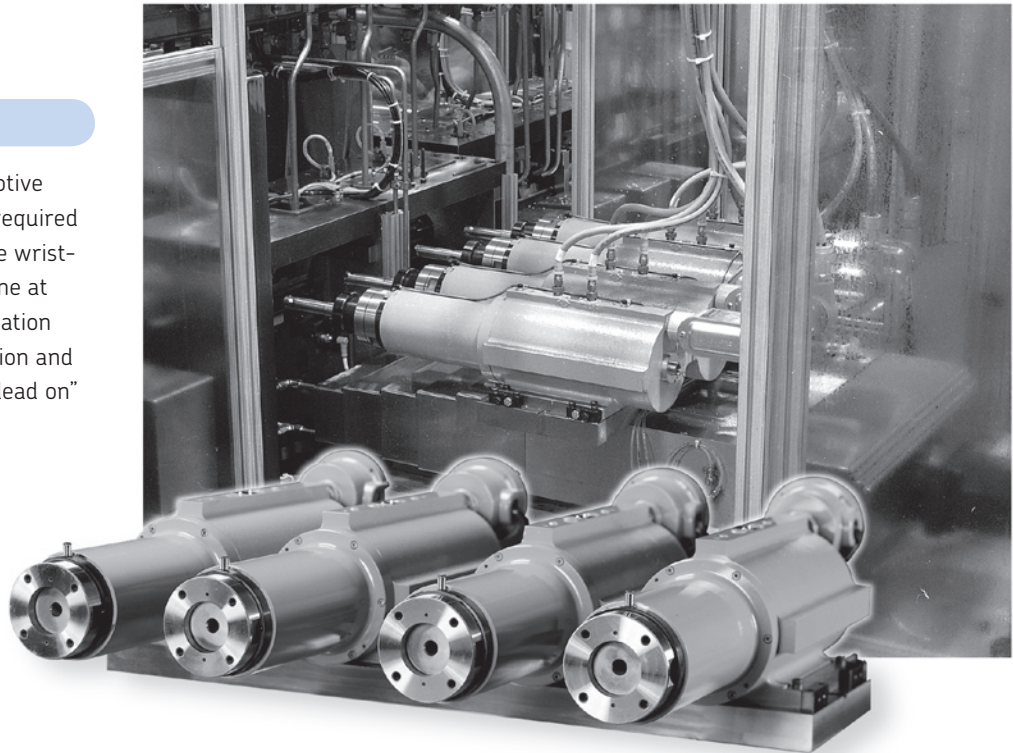

#### Challenge

The spindles at each of the four processing positions had to be highly accurate and vibration free to achieve the end user's surface finish needs. They also had to be mounted close together and

maintain a center-to-center dimension of .001". Since the four spindles would have to move up to the work and then back away from it after the operation was complete, a precision slide would

be required. Overall reliability of the station had to meet the “24-7-365” production needs of today's automotive manufacturing environment.

#### Solution

Four SKF Precision Technologies GLS120 motorized spindles mounted on a HWL24 “low profile” hardened way slide were chosen as the solution. The spindles

featured flanged-foot housings secured to a precision mounting plate atop the ground ball screw-driven slide. The GLS120 spindles were extremely low in

vibration. Their integral motor design minimized the number of moving parts and the spindle shaft and rotor were precision balanced before assembly.

*Continued on page 29.*

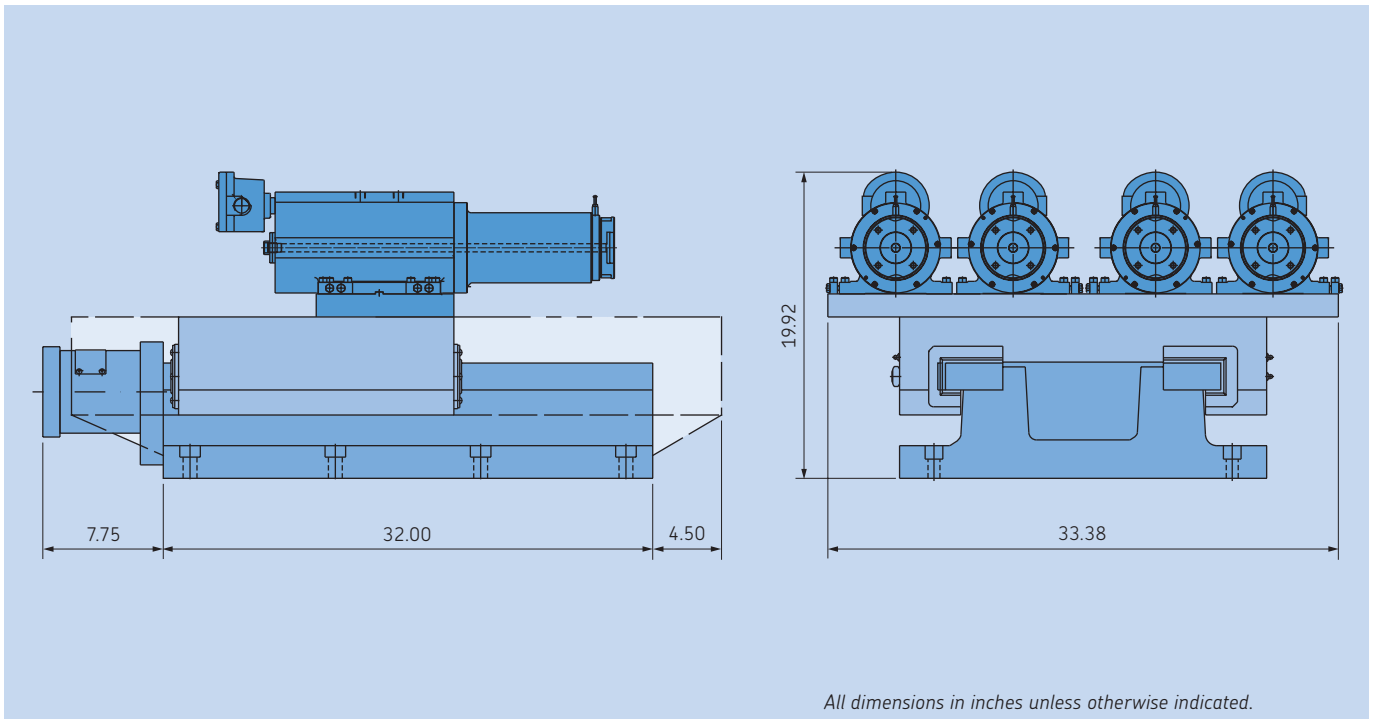

**Solution (continued)**

Precision SKF ABEC 7/9 bearings, a triplex set in the spindle nose and a duplex in the rear, delivered rotational accuracy with a maximum runout of .0001". Liquid cooling of the spindle housing provided a clean and stable environment for the bearings and

motor. The integral motor design of the spindles also contributed to a very compact station. Individual integral motors also helped achieve a control goal for the builder. The ability of the line to process fewer than the four parts per station was felt to be a key feature that

would keep the line running in the event that any of the processing positions at any of the line's stations went down. The rough cut boring station that preceded this finishing station also featured SKF Precision Technologies' spindles and slide components.

**Technical specifications**

- HWL24-18-32-D2-12 slide:
- Base width 24"
  - Saddle length 18"
  - Travel 12"
  - Plumbing for lubrication distribution
  - 2.000-.500 R.H. thread ground ball screw - preloaded nut

- GLS120 spindle:
- Nose end, 55mm I.D., light preloaded, triplex set, ABEC 7, 15° angular contact ball bearings
  - Drive end, 25mm I.D., medium preloaded, duplex set, ABEC 7, 15° angular contact ball bearings
  - Synthetic grease lubrication
  - Labyrinth seal on each end
  - Operating speed 1,800-8,000 rpm
  - Coolant thru-the-spindle shaft
  - Tolerances measured at 74° F

- Integral motor:
- Totally enclosed liquid-cooled (TELC) type motor
  - Inverter-duty type motor

# Idea bulletin

Programmable, adjustable,  
opposing milling modules

## Upstream design and continuous operation save setup time

### Application

A processor of coiled metal wanted to reduce handling time and automate machining operations. The problem was that several different widths and thicknesses of material and hundreds of different milling patterns were combined to produce the company's thousands of products.

### Challenge

Originally the milling operations were done after the material was cut to length. The machine envisioned would position a length of material while still connected to the coil and mill a specific pattern. The company wanted to eliminate the handling and fixturing required for machining after cutting to length.

### Solution

After intensive analysis of the multiple operations required downstream of the cutting-to-length operation, it was determined that the milling operation would be better performed before the material was cut off from the coil. To meet all requirements, this custom machine tool was designed to be adjustable in five axes. The material strip is processed continuously as it moves

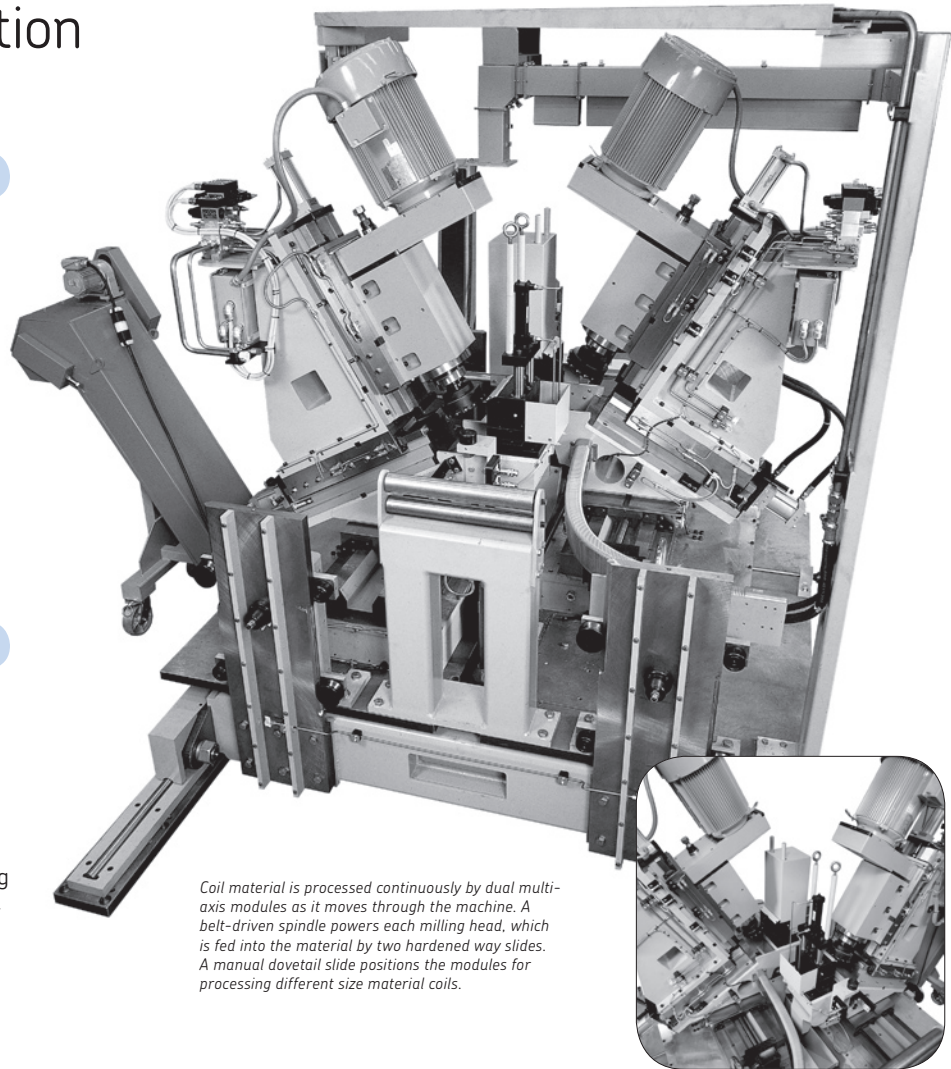

*Coil material is processed continuously by dual multi-axis modules as it moves through the machine. A belt-driven spindle powers each milling head, which is fed into the material by two hardened way slides. A manual dovetail slide positions the modules for processing different size material coils.*

through the machine. The multi-tooth milling head is first fed into the material in two axes. Second, the material is fed through the machine and into the milling head for the required distance. Belt driven spindles are used for the milling operation. The "Y" and "Z" axes are hardened way slides feeding the spindle are controlled by hydraulic cylinders. The "X" axis is a dovetail slide used for

manual adjustments of the two spindles relative to each other. The fourth and fifth axes are for adjusting milling angles and material widths. The machine has been a tremendous success. Hundreds of complicated and error prone operations have been eliminated. Productivity has increased, and the company has been able to expand its product offering with no additional machinery or personnel required.

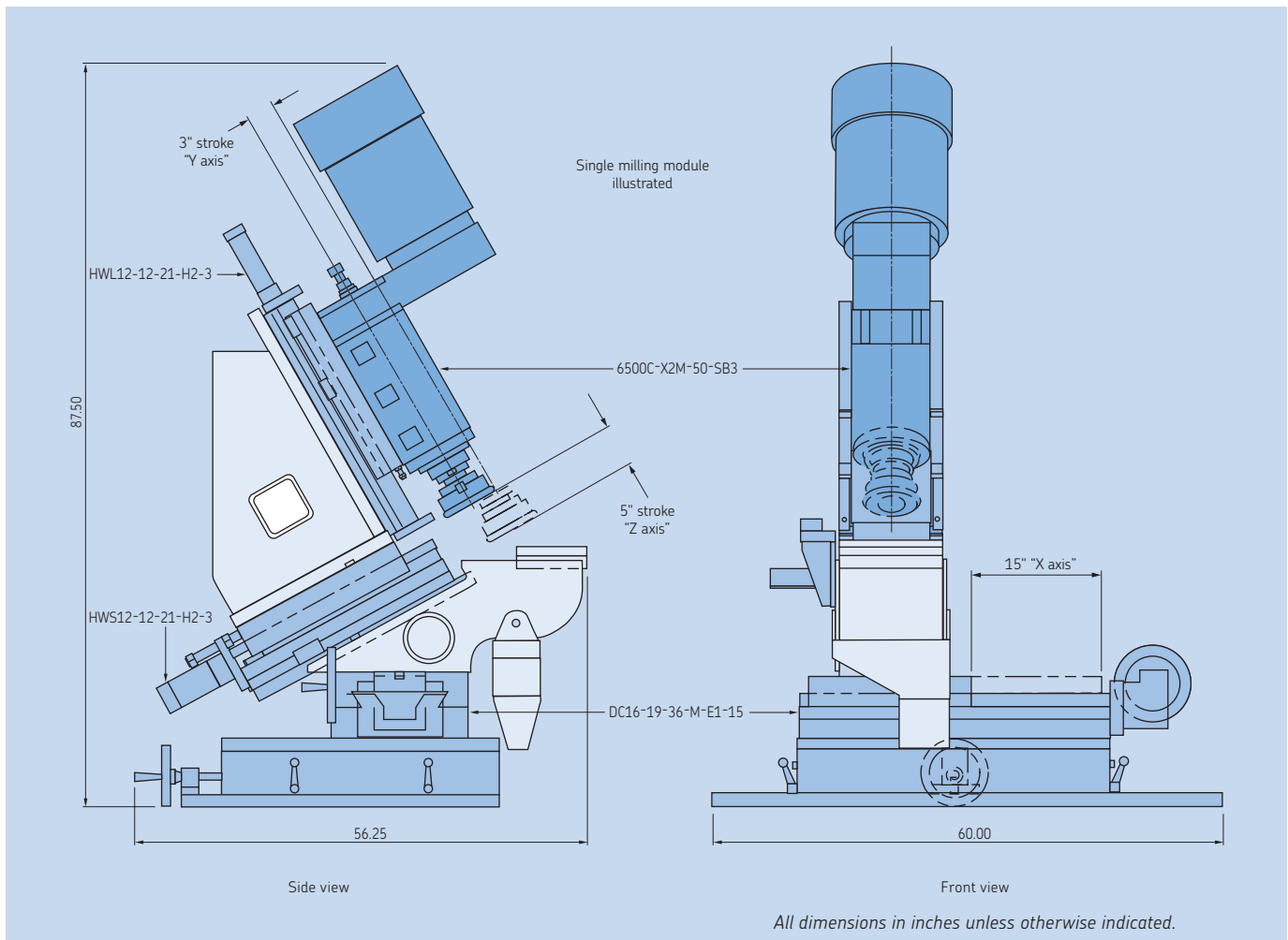

### Cost savings

Not only is the design and operation of the machine successful, but the SKF Precision Technologies components that made it possible are all stock or standard products. This use of existing designs kept the project cost low.

### Sales point

By using stock and standard components to achieve the customer's design goals, cost and delivery time were both minimized.

### Technical specifications

- 2 each HWS12-12-21-H2-3 slide assembly with hydraulic cylinder drive
- 2 each HWL12-22-30-H3-5 slide assembly with hydraulic cylinder drive
- 2 each DC16-19-36-M-E1-15 slide assembly with Acme screw with right angle handwheel
- 2 each 6500C-X2M-50-SB3 belt-driven, motorized spindle
- The customer provided the angle brackets and assembled the machine on their shop floor.



## Europe

### Austria

**SKF Österreich, AG**  
**Spindle Service Centre SSC**  
Telephone: +43 7252 797 731  
Fax: +43 7252 797 732  
e-mail: spindelservice.at@skf.com

### Benelux

**SKF Multitec Benelux B.V.**  
Telephone: +31 30 6029029  
Fax: +31 30 6029028

### Sales office Belgium/Luxembourg

Telephone: +32 2 5024270  
Fax: +32 2 5027336

### Czech Republic

**SKF Loziska, a.s.**  
Telephone: +420 234 642 111  
Fax: +420 234 642 415

### Denmark, Finland, Norway and Sweden

**SKF Multitec AB**  
Telephone: +46 42 253 500  
Fax: +46 42 253 546

### France

**SKF France S.A.**  
Telephone: +33 1 30 12 73 00  
Fax: +33 1 30 12 76 43  
e-mail: skf.france@skf.com

### Germany

**SKF GmbH**  
Telephone: +49 9721 560  
Fax: +49 9721 566000  
e-mail: spindelservice.de@skf.com

### Italy

**GAMFIOR S.p.A.**  
Telephone: +39 011 222 1111  
Fax: +39 011 262 0906  
e-mail: spserv@gamfior.com

### SKF Multitec S.p.A

Telephone: +39 011 22 49 01  
Fax: +39 011 22 49 233

### SKF MT&PT

Telephone: +39 0121 312 551  
Fax: +39 0121 312 550

### Russia

**SKF Moscow**  
Telephone/Fax: +7 095 31 777 01

### Spain

**SKF Española, S.A.**  
Telephone: +34 91 768 42 00  
Fax: +34 91 768 42 62

### SKF Productos Industriales, S.A.

Telephone: +34 93 377 99 77  
Fax: +34 93 474 20 39

### Sweden

**SKF Sverige AB**  
Telephone: +46 31 337 1646  
Fax: +46 31 337 1113  
e-mail: spindelservice.se@skf.com

### Switzerland

**SKF LM&PT Switzerland**  
Telephone: +41 1825 81 81  
Fax: +41 1825 82 82

### United Kingdom

**SKF Machine Tool Sales UK**  
Telephone: +44 (0) 1582 574 858  
Fax: +44 (0) 1582 494 301  
e-mail: spindleservice.uk@skf.com

## North America

### United States

**SKF Precision Technologies,**  
**a unit of SKF USA Inc.**  
**(formerly Russell T. Gilman, Inc.)**  
P.O. Box 5, Grafton, WI 53024-0005  
Telephone: 800 445 6267 or 262 377 2434  
Fax: 262 377 9438  
e-mail: sales@skfpt.com

### TCM, a unit of SKF USA Inc.

69900 Powell Road, Armada, MI 48005  
Telephone: 586 752 0060  
Fax: 586 752 0755  
e-mail: sales@skfpt.com

### SKF Linear Motion & Precision Technologies

1530 Valley Center Parkway  
Bethlehem, PA 18017  
Telephone: 800 221 8325  
Fax: 610 861 3737  
e-mail: sales@skfpt.com

### Canada

**SKF Canada Ltd.**  
40 Executive Court  
Scarborough, ON, M1S 4N4, Canada  
Telephone: 416 299 1220  
Fax: 416 299 0501  
e-mail: marketing@skf.ca

### Mexico

**SKF de Mexico S.A. de C.V.**  
Apartado Postal 855 72000  
Puebla, Pue., Mexico  
Telephone: +52 222 229 4900  
Fax: +52 222 229 4941

## Asia

### China

**SKF China Ltd. - Shanghai**  
Phone: +86 21 5306 8866  
Fax: +86 21 5306 5533

### India

**SKF Bearings India Ltd.**  
Telephone: +91 20 56112477  
Fax: +91 20 27451266  
e-mail: spindleservice.in@skf.com

### Japan

**SKF Japan Ltd.**  
Telephone: +81 3 3436 4129  
Fax: +81 3 3578 1014  
e-mail: spindleservice.jp@skf.com

### Korea

**SKF Korea Ltd.**  
Telephone: +82 (0)51 920 5330  
Fax: +82 (0)51 946 5310

### Malaysia

**SKF Bearing Industries (M) Sdn Bhd**  
Telephone: +606 799 22 00  
Fax: +606 799 27 05

### Taiwan

**SKF Bearing Services Taiwan Ltd.**  
Telephone: +886 4 2565 3166  
Fax: +886 4 2565 3180

## South America

### Brazil

**SKF do Brasil Ltda.**  
Telephone: +55 11 4619 9114  
Fax: +55 11 4619 9199  
e-mail: spindleservice.br@skf.com

Complete product offering  
catalogs, 3D and 2D CAD  
files are available online  
at [www.skfpt.com](http://www.skfpt.com)

© SKF is a registered trademark of SKF USA Inc.

The contents of this publication are the copyright of the publisher and may not be reproduced (even extracts) unless prior written permission is granted.

Every care has been taken to ensure the accuracy of the information contained in this publication but no liability can be accepted for any loss or damage whether direct, indirect or consequential arising out of use of the information contained herein.

©SKF USA Inc. 2006

Publication 707B

(5M/DLC 8/2006)

Version 8/2006

Printed in U.S.A.

**SKF Precision Technologies**