



**Installation,
Operation And Maintenance Of
Reliance[®] Standard
Industrial AC
Induction Motors**

- 180 – 449 Frames (NEMA)
- 112 – 280 Frames (IEC)

AC MOTORS

*“Solutions
You Can
Trust”*

**Instruction Manual B-3620-25
April, 2007**

Table of Contents

RECEIVING AND HANDLING	1
ACCEPTANCE	1
EXTENDED STORAGE – AC MOTORS, DC MOTORS, GENERATORS AND SHIPBOARD MOTORS	1
STORAGE CONDITIONS - SHORT TERM	1
STORAGE PREPARATION	1
FOR STORAGE OF EXTENDED PERIODS OF TIME (GREATER THAN 18 MONTHS).....	2
UNPACKING	2
INSTALLATION	3
INSPECTION	3
LOCATION	4
LIFTING MEANS	4
MOUNTING	4
MOUNTING OF 6 & 8 HOLE MOTOR FRAMES	4
DRIVE	4
ROTATING PARTS	5
SOME SATISFACTORY METHODS OF GUARDING	5
GROUNDING	5
STARTING	6
DRAIN PLUGS	6
ROTATION	6
TEST FOR GENERAL CONDITION.....	6
INITIAL LUBRICATION	6
OPERATION	7
MAINTENANCE AND REPAIR	9
DISASSEMBLY	9
REMOVING BRACKETS AND ROTOR	9
REMOVING AND REPLACING BALL BEARINGS	9
REASSEMBLY	9
LUBRICATION OF BEARINGS	10
GREASE LUBRICATED BEARINGS	10
RECOMMENDED LUBRICANT	10
BALL BEARING MOTORS.....	10
ROLLER BEARING MOTORS	10
LUBRICATION PROCEDURE.....	10
LUBRICATION INSTRUCTIONS.....	10
SERVICE CONDITIONS	11
LUBRICATION FREQUENCY	11
LUBRICATION VOLUME	11
REPLACEMENT BEARINGS	11
GENERAL CROSS SECTION AND PARTS IDENTIFICATION DRAWING	11
TOTAL SERVICE PROGRAMS.....	12

RENEWAL PARTS	12
ADDITIONAL LITERATURE	12

©2007 Baldor Electric Company International Corporation

 **DANGER**

ONLY QUALIFIED ELECTRICAL PERSONNEL FAMILIAR WITH THE CONSTRUCTION AND OPERATION OF THIS EQUIPMENT AND THE HAZARDS INVOLVED SHOULD INSTALL, ADJUST, OPERATE, AND/OR SERVICE THIS EQUIPMENT. READ AND UNDERSTAND THIS MANUAL IN ITS ENTIRETY BEFORE PROCEEDING. FAILURE TO OBSERVE THIS PRECAUTION COULD RESULT IN SEVERE BODILY INJURY OR LOSS OF LIFE.

The products described in this manual are manufactured by or for Reliance Industrial Company.

RECEIVING AND HANDLING

ACCEPTANCE

Thoroughly inspect the equipment before accepting shipment from the transportation company. If any of the goods called for in the bill of lading or express receipt are damaged or the quantity is short, do not accept them until the freight or express agent makes an appropriate notation on your freight bill or express receipt. If any concealed loss or damage is discovered later, notify your freight or express agent at once and request him to make an inspection. We will be very happy to assist you in collecting claims for loss or damage in shipment; however, this willingness on our part does not remove the transportation company's responsibility in reimbursing you for collection of claims or replacement of material. Claims for loss or damage in shipment must not be deducted from the Reliance invoice, nor should payment of the Reliance invoice be withheld awaiting adjustment of such claims, as the carrier guarantees safe delivery.

If considerable damage has been incurred and the situation is urgent, contact the nearest Reliance Sales Office for assistance. Please keep a written record of all communications.

EXTENDED STORAGE – AC MOTORS

If considerable damage has been incurred and the situation is urgent, contact the nearest Reliance Sales Office for assistance. Please keep a written record of all communications.

STORAGE CONDITIONS – SHORT TERM

The following storage requirements must be followed:

1. Motors are to be kept in their original containers or provided with equivalent protection and stored

- in a warehouse free from extremes in temperature, humidity, and corrosive atmosphere.
2. If unusual vibrations exist at the storage location, the motor should be protected with isolation pads.
3. All breathers and drains are to be operable while in storage and/or the moisture drain plugs removed. The motors must be stored so the drain is at the lowest point.

STORAGE PREPARATION

Improper storage of electric machines will result in seriously reduced reliability of that equipment. For example, an electric motor that does not experience regular usage while being exposed to normally humid atmospheric conditions is likely to cause the bearings to rust or rust particles from surrounding surfaces to contaminate the bearings. The electrical insulation may absorb an excessive amount of moisture leading to the motor winding failing to ground. The following preparations should be followed:

1. Minimize condensation in and around the motor by use of desiccants or other humidity control methods.
2. Motor space heaters when specified are to be energized where there is a possibility that the storage ambient conditions will reach the dew point. Space heaters are an option.
3. Coat all external machined surfaces with a material to prevent corrosion. An acceptable product for this purpose is Exxon Rust Ban #392.
4. Measure and record the electrical resistance of the winding insulation with a megger or an insulation resistance meter. Minimum accepted Megohm level is the insulation kV rating +1 Megohm. If levels fall below the above, contact the nearest Reliance sales office. The recorded data will be required when removing from storage.

5. Some motors have a shipping brace attached to the shaft to prevent damage during transportation. The shipping brace, if provided, must be removed and stored for future use. The brace must be reinstalled to hold the shaft firmly in place against the bearing before the motor is moved.
6. Upon placing the motor into extended storage (greater than 3 months), the motors with regreasable bearings must be greased per Table 1 followed by the motor shaft being rotated a minimum of 15 times after greasing. Non-regreasable motors with "Do Not Lubricate" nameplate should also be rotated 15 times to redistribute grease within the bearing.
7. Remove the grease drain plug, if supplied, (opposite the grease fitting) on the bottom of each end bracket prior to lubricating the motor. Replace the plug after greasing.

Table 1. Lubrication Volume (Storage)

NEMA Frame Size (IEC)	Vol. in Cubic In. (Cm³)
182 thru 215 (112 – 132)	0.5 (8)
254 thru 286 (160 – 180)	1.0 (16)
324 thru 365 (200 – 225)	1.5 (24)
404 thru 449 (250 – 280)	2.5 (40)

8. Regreasable bearings are to be greased per Table 1 at the time of being placed into extended storage. Motor shafts are to be rotated at least 15 revolutions manually every 3 months and additional grease added every nine months per Table 1 to each bearing. Bearings are to be greased at the time of removal from storage.
Non-regreasable motors should have their shaft rotated 15 revolutions every 3 months.
9. All breather drains should be fully operable while in storage. The motors must be stored so the drain is at the lowest point. All breathers and automatic "T" drains must be operable to allow breathing at points other than through the bearing fits.
10. The space heaters when specified are to be connected and operable while in storage.
11. Windings are to be meggered at the time equipment is put in storage. Reference Para. 4 on page 1. At the time of removal from storage, the insulation resistance reading must not have dropped more than 50% from the initial reading. Any drop below this

point necessitates electrical or mechanical drying. Refer to "Motor Drying Procedure."

12. Where motors are not stored in the original containers, but are removed and mounted on other pieces of machinery, the mounting must be such that the drains and breathers and space heaters are fully operable. In this respect, the drains must be kept at the lowest point in the motor so that all condensation can automatically drain out.

FOR STORAGE OF EXTENDED PERIODS OF TIME (GREATER THAN 18 MONTHS)

All requirements of general preparation and short term storage apply with the following additional requirements.

1. Motor is to be crated in a box similar to EXPORT BOXING but that the "shell" (sides & top of box) will be LAG-BOLTED to the wooden base (not nailed as export boxes are). This design will allow for the opening and reclosing the box many times without destroying the "shell".
2. The motor will be sealed in an airtight vapor barrier bag with desiccant inside. This airtight bag will give added protection during shipment of motor to the permanent storage area.
3. After the first "Inspection" for megger reading, turning the shaft, etc., the vapor bag should be re-sealed by taping it closed with masking or similar tape. Also add new desiccant inside bag before closing. The shell should then be placed over the motor and the lag bolts replaced.
4. If a "zipper-closing" type bag is used instead of the "heat-sealed" type bag, then rezipper the bag closed instead of taping it.
5. Be sure to add new desiccant inside bag after each periodic inspection.
6. Minimize the accumulation of condensed water in and around the machine.

UNPACKING

After unpacking and inspection to see that all parts are in good condition, turn the shaft by hand to be sure there are no obstructions to free rotation. Equipment which has been in storage for some time should be tested and relubricated (regreasable type) prior to being put into service. Refer to "Test General Condition" and

“Lubrication” for procedure to be performed after extended storage.

Equipment with roller bearings is shipped with a shaft block. After removing the shaft block, be sure to replace any bolts used to hold the shaft block in place during shipment that are required in service.

⚠ DANGER

ONLY QUALIFIED ELECTRICAL PERSONNEL FAMILIAR WITH THE CONSTRUCTION AND OPERATION OF THIS EQUIPMENT AND THE HAZARDS INVOLVED SHOULD INSTALL, ADJUST, OPERATE, AND/OR SERVICE THIS EQUIPMENT. READ AND UNDERSTAND THIS MANUAL IN ITS ENTIRETY BEFORE PROCEEDING. FAILURE TO OBSERVE THIS PRECAUTION COULD RESULT IN SEVERE BODILY INJURY OR LOSS OF LIFE.

INSTALLATION

INSPECTION

After the motor is unpacked, examine the nameplate data to see that it agrees with the power circuit to which it is to be connected. The motor will operate with frequency not more than 5% and voltage not more than 10% above or below the nameplate data, or combined variation of voltage and frequency of not

more than 10% above or below nameplate data. Efficiency, power factor and current may vary from nameplate data. Performance within these voltage and frequency variations will not necessarily be in accordance with the standards established for operation at rated voltage and frequency.

Typical Effect of Voltage and Frequency Variation on Induction Motor Characteristics

Variation	Starting and maximum running torque	Synchronous speed	slip %	Full-Load Speed	Efficiency			Power Factor/COS ϕ			Full-load current	Starting current	Temp rise, full load	Maximum overload capacity	Magnetic noise – no-load in particular
					Full-load	3/4 load	1/2 load	Full load	3/4 load	1/2 load					
Voltage Variation:															
120% Voltage	Increase 44%	no change	decrease 30%	Increase 1.5%	6-0% decrease (1-75 HP) 0-3% Increase (100-300 HP)	decrease 1/2-2 points	decrease 7-20 points	decrease 5-15 points	decrease 10-30 points	decrease 15-40 points	Increase 12%	Increase 20%	Increase 5-6°C. (1-75 HP) Decrease 3-4°C (100-300 HP)	Increase 44%	Noticeable Increase
110% voltage	Increase 21%	no change	decrease 17%	Increase 1%	slight decrease	practically no change	decrease 1-2 points	decrease 5-10 points	decrease 5 points	decrease 5-6 points	Increase 2-4%	Increase 10-12%	Increase 3-4°C.	Increase 21%	Increase slightly
Function of Voltage	(voltage) ²	constant	$\frac{1}{(\text{voltage})^2}$	(synchronous speed slip)								voltage		(voltage) ²	
90% Voltage	decrease 19%	no change	Increase 23%	decrease 1-1/2%	decrease 2 points	practically no change	Increase 1-2 points	Increase 5 points	Increase 2-3 points	Increase 4-5 points	Increase 10-11%	decrease 10-12%	Increase 6-7°C	decrease 19%	decrease slightly
Frequency variation:															
105% frequency	decrease 10%	Increase 5%	practically no change	Increase 5%	slight increase	slight increase	slight increase	slight increase	slight increase	slight increase	decrease slightly	decrease 5-6%	decrease slightly	decrease slightly	decrease slightly
Function of frequency	$\frac{1}{(\text{frequency})^2}$	frequency		(synchronous speed slip)								$\frac{1}{\text{frequency}}$			
95% frequency	Increase 11%	decrease 5%	practically no change	decrease 5%	slight decrease	slight decrease	slight decrease	slight decrease	slight decrease	slight decrease	Increase slightly	Increase 5-6%	Increase slightly	Increase slightly	Increase slightly
1 % phase unbalance	slight decrease	slight decrease		slight decrease	2% decrease			5-6% decrease			1-1/2% increase	slight decrease	2% increase		
2% phase unbalance	slight decrease	slight decrease		slight decrease	8% decrease			7% decrease			3% increase	slight decrease	8% increase		

NOTE: This table shows general effects, which will vary somewhat for specific ratings.

LOCATION

The motor should be installed in a location compatible with the motor enclosure and specific ambient.

To allow adequate air flow, the following clearances must be maintained between the motor and any obstruction:

TEFC(IC0141) Enclosures	-		
Fan Cover Air Intake	-	180 – 210T Frame	1"
		250 – 449T Frame	4"
		IEC 112 – 132	2.5 cm
		IEC 160 – 280	10 cm
Exhaust	-	Envelope equal to the "P" dimension on the motor dimension sheet	
Protected Enclosures	-		
Bracket Intake	-	Same as TEFC	
Frame Exhaust	-	Exhaust out the sides-envelope a minimum of the "P" dimension plus 2" (5cm). Exhaust out the end-same as intake.	

LIFTING MEANS

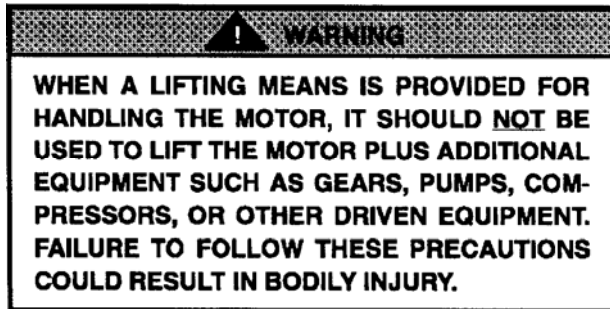

In the case of assemblies on a common base, any lifting means provided on the motor or generator should not be used to lift the assembly and base but, rather, the assembly should be lifted by a sling around the base or by other lifting means provided on the base. In all cases care should be taken to assure lifting in the direction intended in the design of the lifting means. Likewise, precautions should be taken to prevent hazardous overloads due to deceleration, acceleration or shock forces.

MOUNTING

Mount the motor on a foundation sufficiently rigid to prevent excessive vibration. Roller bearing and ball-bearing motors may be mounted with the shaft at any angle. Roller bearing motors are not suitable for coupled duty applications. After carefully aligning the motor with the driven unit, bolt securely in place.

When motors, which are normally mounted with the shaft in a horizontal position, are mounted vertically, it may be necessary to provide additional guards to prevent foreign objects from falling into the motor openings and striking rotating parts. Such guards may be obtained at the time of purchase or from a local service repair center.

Explosion proof motors are shipped from the factory with the conduit box mounted. If the conduit box is removed or rotated, a minimum of five (5) full threads of engagement on the motor pipe nipple must be maintained for explosion proof integrity of the conduit box.

Some motors have standardized frames containing 6 or 8 mounting holes. 6 hole frames are not suitable for field reversal of mounting from F-1 to F-2, etc. The following diagram indicates the proper mounting holes to use.

MOUNTING OF 6 & 8 HOLE MOTOR FRAMES

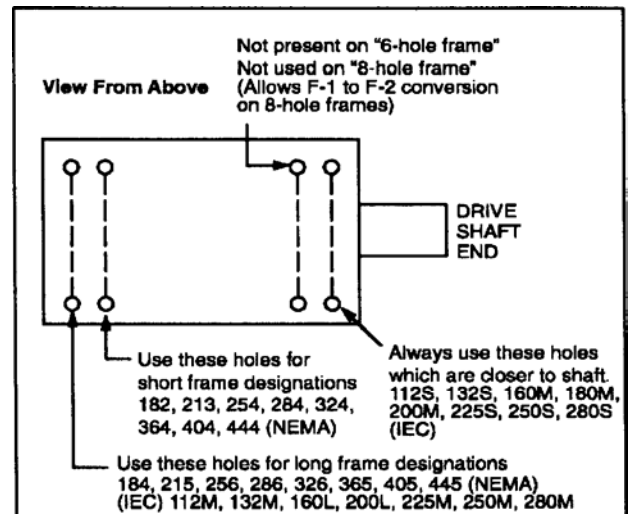

DRIVE

The pulley, sprocket, or gear used in the drive should be located on the shaft as close to the shaft shoulder as possible. Heat to install. Driving a unit on the shaft will damage the bearings.

Chain Drive: Mount the sprocket on the shaft as close to the bracket as possible. Align the sprockets so that the chain will run true. Avoid excessive chain tension.

Gear Drive and Direct Connection: Accurate alignment is essential. Secure the motor and driven unit rigidly to the base.

ROTATING PARTS

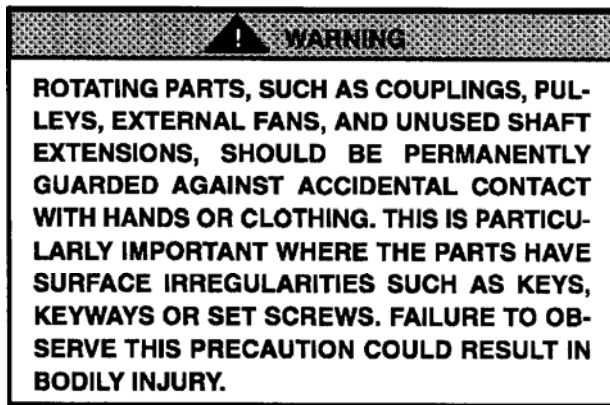

SOME SATISFACTORY METHODS OF GUARDING ARE:

1. Covering the machine and associated rotating parts with structural or decorative parts of the driven equipment.
2. Providing covers for the rotating parts. Covers should be sufficiently rigid to maintain adequate guarding in normal service.

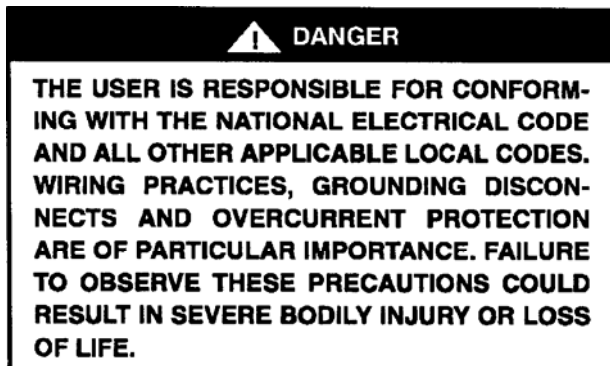

Belt Drive: Align the pulleys so that the belt will run true; tighten the belt just enough to prevent slippage, any tighter will cause premature bearing failure. If possible, the lower side of the belt should be the driving side.

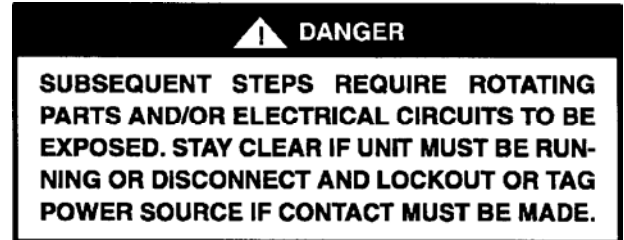

Connect the motor to the power supply according to the diagram on the motor nameplate. For most 230/460 volt motors, nine leads are brought out from the stator windings so that the motor may be connected for either 230 or 460 volts.

GROUNDING

In the USA consult the *National Electrical Code*, Article 430 for information on grounding of motors, Article 445 for grounding of generators, and Article 250 for general information on grounding. In making the ground connection, the installer should make certain that there is a solid and permanent metallic connection between the ground point, the motor or generator terminal housing, and the motor or generator frame. In non-USA locations consult the appropriate national or local code applicable.

Motors with resilient cushion rings usually must be provided with a bonding conductor across the resilient member. Some motors are supplied with the bonding conductor on the concealed side of the cushion ring to protect the bond from damage. Motors with bonded cushion rings should usually be grounded at the time of installation in accordance with the above recommendations for making ground connections. When motors with bonded cushion rings are used in multimotor installations employing group fusing or group protection, the bonding of the cushion ring should be checked to determine that it is adequate for the rating of the branch circuit overcurrent protective device being used.

There are applications where grounding the exterior parts of a motor or generator may result in greater hazard by increasing the possibility of a person in the area simultaneously contacting ground and some other nearby live electrical parts of other ungrounded electrical equipment. In portable equipment it is difficult to be sure that a positive ground connection is maintained as the equipment is moved, and providing a grounding conductor may lead to a false sense of security.

The user must select a motor starter and overcurrent protection suitable for this motor and its application. Consult motor starter application data as well as the

National Electric Code and/or other applicable local codes.

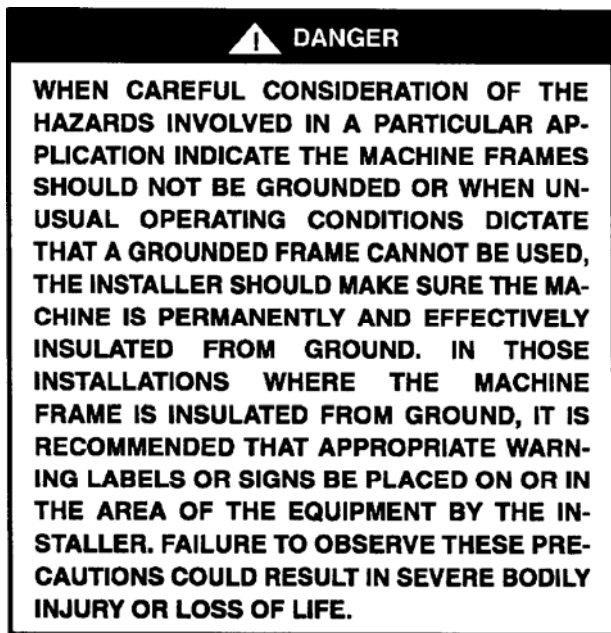

STARTING

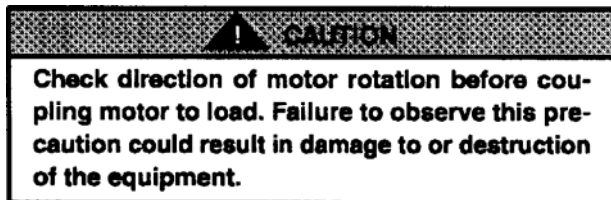
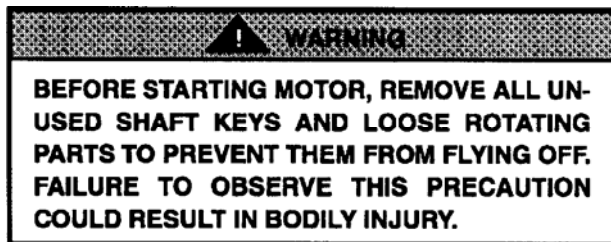

Before starting the motor, check the following items:

1. The rotor should turn freely when disconnected from the load.
2. Driven machine should be unloaded when first starting the motor.

The motor should run smoothly with little noise. If the motor should fail to start and produces a decided hum, it may be that the load is too great for the motor or that it has been connected improperly. Shutdown immediately and investigate for trouble.

DRAIN PLUGS

If motor is totally enclosed fan-cooled or non-ventilated it is recommended that condensation drain plugs, if present, be removed. These are located in the lower portion of the end-shields. Totally enclosed fan-cooled "XT" motors are normally equipped with automatic drains which may be left in place as received.

ROTATION

To reverse the direction of rotation, disconnect from power source and interchange any two of the three line leads for the three-phase motors.

TEST FOR GENERAL CONDITION

If the motor has been in storage for an extensive period or has been subjected to adverse moisture conditions, it is best to check the insulation resistance of the stator winding with a megohmmeter. If the resistance is lower than one megohm the windings should be dried in one of the two following ways:

1. Bake in oven at temperatures not exceeding 90°C. until insulation resistance becomes constant.
2. With rotor locked, apply low voltage and gradually increase current through windings until temperature measured with thermometer reaches 194°F (90°C). Do not exceed this temperature.

INITIAL LUBRICATION

Reliance motors are shipped from the factory with the bearings properly packed with grease and ready to operate. Where the unit has been subjected to extended storage (6 months or more) the bearings should be relubricated (regreasable type) prior to starting. When motors are equipped for oil mist lubrication refer to Instruction Manual B-3654.

OPERATION

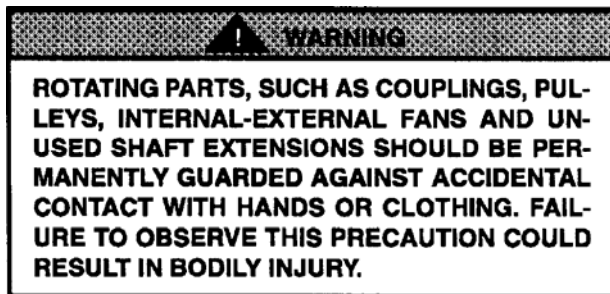
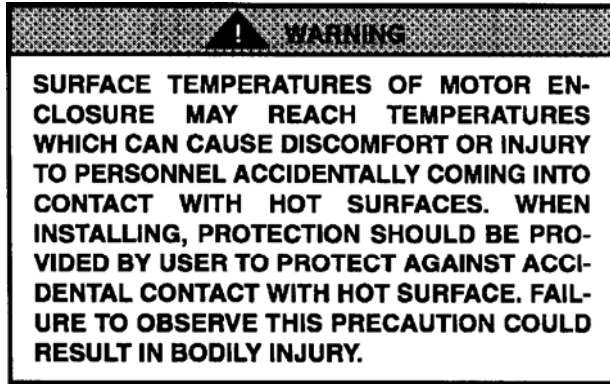

Due to the inherent characteristics of insulating materials, abnormally high temperatures shorten the operating life of electrical apparatus. The total temperature, not the temperature rise, should be the measure of safe operation. The class of insulation determines the maximum safe operating temperature. Aging of insulation occurs at an accelerated rate at abnormally high temperatures. A general rule for gauging the effect of excessive heat is that for each 10°C. rise in temperature above the maximum limit for the insulation, the life of the insulation is halved.

Unbalanced voltage or single-phase operation of poly-phase machines may cause excessive heating and limate failure. It requires only a slight unbalance of voltage applied to a polyphase motor

to cause large unbalance currents and resultant overheating.

Periodic checks of phase voltage, frequency and power consumption of a motor while in operation are recommended; such checks assure the correctness of frequency and voltage applied to the motor and yield an indication of the load offered by the apparatus which the motor drives.

Comparisons of this data with previous no-load and full-load power demands will give an indication of the performance of the complete machine. Any serious deviations should be investigated and corrected.

Stator troubles can usually be traced to one of the following causes:

Worn bearings	Operating single-phase
Moisture	Poor insulation
Overloading	Oil and dirt

Dust and dirt are usually contributing factors. Some forms of dust are highly conductive and contribute materially to insulation breakdown. The effect of dust on the motor temperature through restriction of ventilation is a principal reason for keeping the windings clean.

Squirrel-cage rotors are rugged and, in general, give little trouble. The first symptom of a defective rotor is lack of torque. This may cause a slowing down in speed accompanied by a growling noise or perhaps failure to start the load.

This is caused by an open or high resistance joint in the rotor bar circuit. Such a condition can generally be detected by looking for evidence of localized heating.

Motors with maximum surface temperatures listed on the nameplates.

! ATTENTION

THE MOTOR IS DESIGNED TO OPERATE AT OR BELOW THE MAXIMUM SURFACE TEMPERATURE STATED ON THE NAMEPLATE. FAILURE TO OPERATE THE MOTOR PROPERLY CAN CAUSE THIS MAXIMUM SURFACE TEMPERATURE TO BE EXCEEDED. IF APPLIED IN A DIVISION 2 OR ZONE 2 ENVIRONMENT THIS EXCESSIVE TEMPERATURE MAY CAUSE IGNITION OF HAZARDOUS MATERIALS. OPERATING THE MOTOR AT ANY OF THE FOLLOWING CONDITIONS CAN CAUSE THE MARKED TEMPERATURE TO BE EXCEEDED.

1. MOTOR LOAD EXCEEDING SERVICE FACTOR VALUE
2. AMBIENT TEMPERATURES ABOVE NAMEPLATE VALUE
3. VOLTAGES ABOVE OR BELOW NAMEPLATE VALUE
4. UNBALANCED VOLTAGES
5. LOSS OF PROPER VENTILATION
6. VARIABLE FREQUENCY OPERATION
7. ALTITUDE ABOVE 3000 FEET/1000 METERS
8. SEVERE DUTY CYCLES, REPEATED STARTS
9. MOTOR STALL
10. MOTOR REVERSING
11. SINGLE PHASE OPERATION

Division 2 or Zone 2 motor swith space heaters.

! ATTENTION

THE SPACE HEATERS ARE DESIGNED TO OPERATE AT OR BELOW THE MAXIMUM SURFACE TEMPERATURE STATED ON THE NAMEPLATE. IF THE MARKED AMBIENT AND/OR VOLTAGE ARE EXCEEDED THIS MAXIMUM SURFACE TEMPERATURE CAN BE EXCEEDED AND CAN DAMAGE THE MOTOR WINDINGS. IF APPLIED IN A DIVISION 2 OR ZONE 2 ENVIRONMENT THIS EXCESSIVE TEMPERATURE MAY CAUSE IGNITION OF HAZARDOUS MATERIALS.

MAINTENANCE AND REPAIR

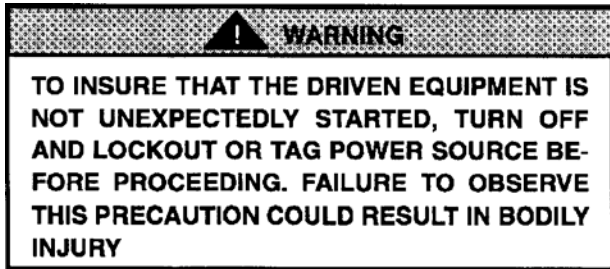

The fundamental principle of electrical maintenance is **KEEP THE APPARATUS CLEAN AND DRY**. This requires periodic inspection of the motor, the frequency depending upon the type of motor and the service.

The following should be checked at regular intervals:

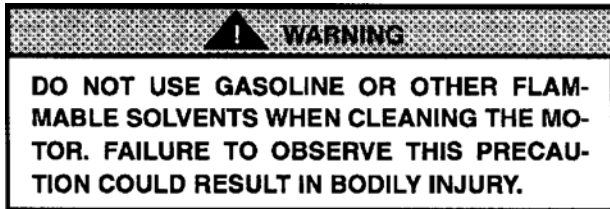

1. Windings should be dry and free of dust, grease, oil, and dirt. Windings may be cleaned by suction cleaners or by wiping. Nozzles on suction cleaners should be non-metallic. Gummy deposits of dirt and grease may be removed by using a commercially available low volatile solvent.
2. Terminal connections, assembly screws, bolts and nuts should be tight. They may loosen if motor is not securely bolted and tend to vibrate.
3. Insulation resistance of motors in service should be checked periodically at approximately the same temperature and humidity conditions to determine possible deterioration of the insulation. When such measurements at regular intervals indicate a wide variation, the cause should be determined. Motor should be reconditioned if the motor has been subjected to excessive moisture by re-winding or re-insulating if necessary. Enclosed motors require very little attention. Be sure that external air chamber of fan-cooled motors does not become clogged with foreign material which will restrict passage of air.

DISASSEMBLY

If it becomes necessary to disassemble the motor, care should be taken not to damage the stator windings as the insulation may be injured by improper or rough handling. Precautions to keep bearings clean should be exercised. Before removing either and shield:

1. Disconnect motor from power source. Tag the leads to insure proper reconnection.
2. Remove motor from mounting base. Remove fan cover and fan if present.
3. Mark end brackets relative to position on frame so they can be easily replaced.

REMOVING BRACKETS AND ROTOR

4. Remove bearing cartridge nuts or screws. (If used)
5. Remove opposite drive end bracket bolts.
6. Pull bracket.
7. Remove drive end bracket in same manner.
8. Remove rotor.

REMOVING AND REPLACING BALL BEARINGS

BEARINGS SHOULD NOT BE REMOVED UNLESS THEY ARE TO BE REPLACED. WHEN REMOVAL IS NECESSARY, USE A BEARING PULLER. A BEARING PULLER MAY BE RIGGED BY USING A METAL PLATE, WITH HOLES DRILLED TO MATCH THE TAPPED HOLES IN THE INNER CAP. USE CARE TO KEEP THE PRESSURE EQUAL TO PREVENT BREAKING THE CAP.

TO INSTALL A BEARING, HEAT THE BEARING IN AN OVEN AT 250°F (121°C). THIS WILL EXPAND THE INNER RACE, ALLOWING IT TO SLIP OVER THE BEARING SEAT. ALL BEARINGS MUST BE REPLACED WITH THE IDENTICAL PART USED BY RELIANCE. IN MANY CASES SPECIAL BEARINGS ARE USED WHICH CANNOT BE IDENTIFIED BY MARKINGS ON BEARING. IN ALL CASES, WHEN REPLACING BEARINGS, USE MARKINGS ON BEARINGS AND MOTOR IDENTIFICATION NUMBER TO OBTAIN CORRECT REPLACEMENT BEARING.

THE MAJORITY OF BEARINGS USED NOW HAVE A C3 INTERNAL FIT.

REASSEMBLY

Follow reverse procedure as outlined for Disassembly. Having marked the brackets in the original position, replace as marked.

LUBRICATION OF BEARINGS

Motors covered by this Instruction Manual are equipped with several types of bearings. This description covers regreasable anti-friction bearings only. Non-regreasable ball bearings require no periodic maintenance. See I/M B-3654 for oil mist lubricated anti-friction bearing procedures.

GREASE LUBRICATED BEARINGS

This motor has been properly lubricated at the time of manufacture and it is not necessary to lubricate at time of installation unless the motor has been in storage for a period of six months or more.

Lubrication of anti-friction bearings should be done as a part of a planned maintenance schedule. The Recommended Lubrication Interval should be used as a guide to establish this schedule.

Cleanliness is important in lubrication. Any grease used to lubricate anti-friction bearings should be fresh and free from contamination. Similarly, care should be taken to properly clean the grease inlet area of the motor to prevent grease contamination.

RECOMMENDED LUBRICANT

For motors operating in ambient temperatures shown below, use the following lubricant or its equal:

BALL BEARING MOTORS

OPERATING TEMP. -25°C (-15°F) to 50°C (120°F)

CHEVRON OIL	SRI NO. 2
EXXON	UNIREX N2
SHELL OIL CO.	DOLIUM R
TEXACO, INC.	PREMIUM RB

MINIMUM STARTING TEMPERATURE -60°C (-76°F)

SHELL OIL CO. AEROSHELL 7

ROLLER BEARING MOTORS

OPERATING TEMP. -25°C (-15°F) to 50°C (120°F)

CHEVRON OIL	BLACK PEARL EP NO.2
TEXACO, INC.	PREMIUM RB

LUBRICATION PROCEDURE

Reliance regreasable anti-friction bearings may be lubricated with the motor running or stationary. Stationary with the motor warm is preferred.

1. Locate the grease inlet, clean the area and replace the pipe plug with a grease fitting, if the motor is not equipped with grease fittings.
2. If motor is equipped with grease drain plug, remove plug and loosen any hardened grease that may block drain.
3. Add the Recommended Volume of the Recommended Lubricant using a hand operated grease gun.
4. Run the motor for two hours.
5. Replace the pipe plug in grease drain.
6. Grease may not relieve from drain. Use only volume shown in Table 3.

LUBRICATION INSTRUCTIONS

1. Select Service Condition from Table 1.
2. Select Lubrication Frequency from Table 2.
3. Select Lubrication Volume from Table 3.
4. Lubricate the motor at the required frequency with the required lubricant volume in accordance with LUBRICATION PROCEDURE.

NOTE: Mixing lubricants is not recommended due to possible incompatibility. If it is desired to change lubricant, follow instructions for lubrication and repeat lubrication a second time after 100 hours of service. Care must be taken to look for signs of lubricant incompatibility, such as extreme soupiness visible from the grease relief drain area, or from the shaft opening.

SERVICE CONDITIONS

Table 1

Standard Conditions	Eight hours per day, normal or light loading, clean @ 40°C (100°F) maximum ambient.
Severe Conditions	Twenty-four hour per day operation or shock loading, vibration, or in dirt or dust @ 40–50°C (100–120° F) ambient
Extreme Conditions	Heavy shock or vibration, or dust.

LUBRICATION VOLUME

Table 3

NEMA (IEC) Frame Size	Volume In Cubic Inches (cm ³)
182 Thru 215 (112 – 132)	0.5 (8)
254 Thru 286 (160 – 180)	1.0(16)
324 Thru 365 (200 – 225)	1.5 (24)
404 Thru 449 (250 – 280)	2.5 (40)

LUBRICATION FREQUENCY

Table 2

BALL BEARINGS				
Speed	NEMA (IEC) FRAME	Standard Conditions	Severe Conditions	Extreme Conditions
1800 RPM and Slower	182 (112) Thru 215 (132)	3 Years	1 Year	6 Months
	254 (160) Thru 365 (200)	2 Years	6 to 12 Months	3 Months
	404 (225) Thru 449 (280)	1 Year	6 Months	1 to 3 Months
3600 RPM	ALL	6 Months	3 Months	1 Month
ROLLER BEARINGS				
For Roller Bearings divide the time periods above by 2.				

REPLACEMENT BEARINGS

Your maintenance program will not be complete without including spare bearings. It must be remembered that the bearing is a wearable component and therefore must eventually be replaced. To insure that you are able to maintain original operation, **we recommend the purchase of spares directly from Reliance.**

All bearings used in Reliance motors are subject to exact specifications and tests necessary to satisfy performance requirements. In this manner, it is possible to duplicate your present bearing. Markings on the bearing do not indicate complete specifications.

CROSS SECTIONAL AND PARTS IDENTIFICATION DRAWING

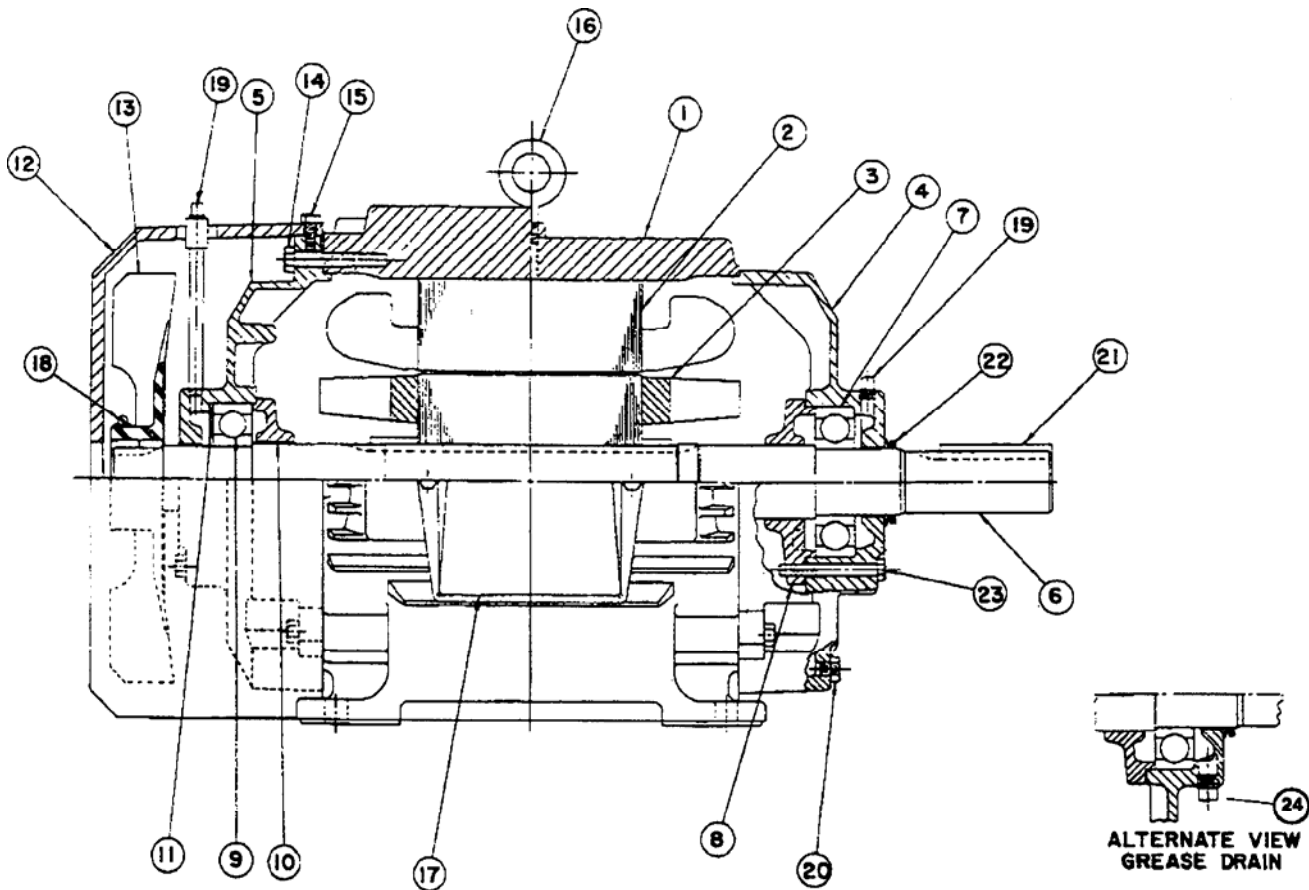

FIND NO.	PART DESCRIPTION
1	FRAME
2	STATOR
3	ROTOR/INTERNAL COOLING FAN
4	BACKEND BRACKET
5	FRONTEND BRACKET
6	SHAFT
7	BACKEND BALL BEARING
8	BACKEND INNER CAP
9	FRONTEND BALL BEARING
10	FRONTEND INNER CAP
11	WAVE WASHER, FRONTEND
12	FAN COVER
13	OUTER COOLING FAN

NOTE: Bearings shown are regreasable type. Not all items shown may be present on motor. Not all items on motor may be shown on drawing. Drawing is for general reference purposes only.

FIND NO.	PART DESCRIPTION
14	FRONT END BRACKET BOLTS
15	FAN COVER BOLTS
16	EYEBOLT
17	TERMINAL BOX
18	FAN CLAMP

19	GREASE ENTRY
20	CONDENSATION DRAIN
21	KEY
22	SLINGER
23	BACKEND CAP BOLTS
24	GREASE DRAIN

TOTAL SERVICE PROGRAMS

Reliance can provide a wide range of maintenance programs to help you reduce downtime, improve productivity and increase profits. Capabilities include:

- Motor Start-Up Service
- Motor Electrical and Mechanical Preventive Maintenance
- Vibration Analysis
- Mobile Van Repair Service
- Balancing and Alignment Service
- Maintenance Schools
- 24-Hour Technical Support
- Modernization Service

For more information contact your local Reliance Sales Office or write:

Attn: Motor Tech Support
 Reliance
 Industrial Services
 375 Alpha Drive
 Highland Hts., Ohio 44143
 USA

RENEWAL PARTS

An adequate stock of factory-made renewal parts is an integral part of a sound maintenance program to protect against costly downtime.

Parts can be obtained from your nearest Reliance parts distributor, or directly from the Reliance factory. When ordering parts for which a part number is not available, give complete description of part and purchase order number, serial number, model number, etc., of the equipment on which the part is used.

A detailed parts list, which gives Reliance recommendations for spare parts that should be stocked for your equipment, can be ordered from:

1. Nearest Reliance Sales Office
2. Nearest Reliance Keypads Distributor
3. Reliance Renewal Parts, Cleveland, Ohio

Be sure to include complete nameplate data-purchase order number, serial number, rating, etc. – for your equipment when ordering the spare parts list.

For the telephone number (USA) of your local Keyparts Stocking distributor call 1-800-RELIANCE.

ADDITIONAL LITERATURE

Additional literature covering the maintenance of AC motors can be obtained from the Reliance Services Division. Requests should be submitted through your nearest Reliance Sales Office.

MOTOR PURCHASE RECORD

RELIANCE DUTY MASTER MOTORS			
I.D. # _____		LOCAL ITEM# _____	
HP/KW _____		SPEED _____	VOLT _____
P.O. #: _____		Purchase Contact/Phone # _____	
Date Purchased: _____			
Comments on maintenance/maintenance log _____			
Date	Item	Remarks	Initials

www.baldor.com www.ptplace.com www.dodge-pt.com www.reliance.com



Baldor Electric Company Headquarters

P.O. Box 2400, Fort Smith, AR 72902-2400 U.S.A., Ph: (1) 479.648.5792, Fax (1) 479.648.5792, International Fax (1) 479.648.5895

DODGE/Reliance Division

6040 Ponders Court, Greenville, SC 29615-4617 U.S.A., Ph: (1) 864.297.4800, FAX: (1) 864.281.2433

B-3620-25 04/07 Copyright © 2007 Baldor Electric Company All Rights Reserved. Printed in USA.

This material is not intended to provide operational instructions. Appropriate instruction manuals and precautions should be studied prior to installation, operation or maintenance of equipment.

Wherever you need us, Baldor Electric Company brings together leading brands in industrial automation including Allen-Bradley controls. Reliance power transmission products, Dodge mechanical power transmission components, and Baldor Electric Company Software. Baldor Electric Company's unique, flexible approach to helping customers achieve a competitive advantage is supported by thousands of authorized partners, distributors and system integrators around the world.