

DEPARTMENT OF THE ARMY

TM 5-6115-332-14

TECHNICAL MANUAL

DEPARTMENT OF THE NAVY

P-8-614-14

PUBLICATION

DEPARTMENT OF THE AIR FORCE

TO 35C2-3-424-1

TECHNICAL ORDERS

TECHNICAL MANUAL

OPERATOR, ORGANIZATIONAL, INTERMEDIATE
(FIELD), (DIRECT SUPPORT AND GENERAL SUPPORT),
AND DEPOT LEVEL MAINTENANCE MANUAL

GENERATOR SET, TACTICAL, GASOLINE ENGINE: AIR COOLED,
5 KW, AC, 120/240V SINGLE PHASE,
120/208V 3 PHASE, SKID MOUNTED,
TUBULAR FRAME (LESS ENGINE) MILITARY DESIGN

| DOD MODEL | CLASS | HERTZ | NSN |
|-----------|---------|-------|------------------|
| MEP-017A | UTILITY | 60 | 6115-00-017-8240 |
| MEP-022A | UTILITY | 400 | 6115-00-017-8241 |

This copy is a reprint which includes current
pages from Changes 1 through 9.

PUBLISHED UNDER THE AUTHORITY OF THE DEPARTMENTS OF THE ARMY,
AIR FORCE AND NAVY

DECEMBER 1977

CHANGE
NO. 10

HEADQUARTERS
DEPARTMENTS OF THE ARMY, THE NAVY AND THE AIR FORCE
WASHINGTON, D C, 23 September 1996

OPERATOR, ORGANIZATIONAL, INTERMEDIATE (FIELD),
(DIRECT SUPPORT AND GENERAL SUPPORT), AND DEPOT LEVEL
MAINTENANCE MANUAL

**GENERATOR SET, TACTICAL, GASOLINE ENGINE: AIR COOLED,
5 KW, AC, 120/240V SINGLE PHASE,
120/208V 3 PHASE, SKID MOUNTED,
TUBULAR FRAME (LESS ENGINE) MILITARY DESIGN**

| DOD MODEL | CLASS | HERTZ | NSN |
|-----------|---------|-------|------------------|
| MEP-017A | UTILITY | 60 | 6115-00-017-8240 |
| MEP-022A | UTILITY | 400 | 6115-00-017-8241 |

DISTRIBUTION STATEMENT A: Approved for public release, distribution is unlimited

TM 5-6115-332-14/P-8-614-14/TO 35C2-3-424-1, 9 December 1977, is changed as follows.

1. Remove and insert pages as indicated below. New or changed text material is indicated by a vertical bar in the margin. An illustration change is indicated by a miniature pointing hand.

Remove pages
i and i
1-1 and 1-2
3-3 and 3-4
4-15 and 4-16
5-3 and 5-4
FO-2

Insert pages
i and ii
1-1 and 1-2
3-3 and 3-4
4-15 and 4-16
5-3 and 5-4
FO-2

2. Retain this sheet in front of manual for reference purposes.

TM 5-6115-332-14
P-8-614-14
TO 35C2-3-424-1
C 10

By Order of the Secretaries of the Army, the Navy and the Air Force:

Official:

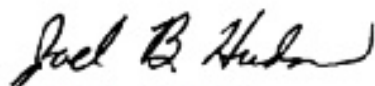

JOEL B. HUDSON
*Administrative Assistant to the
Secretary of the Army*
02150

DENNIS J. REIMER
*General, United States Army
Chief of Staff*

J.E. BUFFINGTON
Rear Admiral, CEC, US Navy
Commander
Navy Facilities Engineering
Command

HENRY VICCELLIO, JR.
*General, USAF
Commander, Air Force Materiel Command*

RONALD R. FOGELMAN
*General, USAF
Chief of Staff*

DISTRIBUTION:

To be distributed in accordance with DA Form 12-25-E, block no. 0889, requirements for TM 5-6115-332-14.

CHANGE

HEADQUARTERS,
DEPARTMENTS OF THE ARMY, NAVY AND AIR FORCE
WASHINGTON, D.C., 10 January 1991

NO. 9

Operator, Organizational, Intermediate (Field)
(Direct Support and General Support),
and Depot Level Maintenance Manual

**GENERATOR SET, TACTICAL, GASOLINE ENGINE, AIR COOLED,
5 kW, AC, 120/240 V SINGLE PHASE, 120/280 V 3 PHASE, SKID MOUNTED,
TUBULAR FRAME (LESS ENGINE) MILITARY DESIGN**

| DOD MODEL | CLASS | HERTZ | NSN |
|-----------|---------|-------|------------------|
| MEP-017A | UTILITY | 60 | 6115-00-017-8240 |
| MEP-022A | UTILITY | 400 | 6115-00-017-8241 |

Approved for public release; distribution is unlimited

TM 5-6115-332-14/P-8-614-14/TO 35C2-3-424-1, 9 December 1977 is changed as follows:

1. Remove and insert pages as indicated below. New or changed text material is indicated by a vertical bar in the margin. An illustration change is indicated by a miniature pointing hand.

Remove pages

7-1 and 7-2
7-2.1/(7-2.2 blank)
7-3 and 7-4

Insert pages

7-1 and 7-2
7-2.1/(7-2.2 blank)
7-3 and 7-4

2. Retain this sheet in front of manual for reference purposes.

ARMY TM 5-6115-332-14
NAVFAC P-8-614-14
AIR FORCE TO 35C2-3-424-1
C9

By Order of the Secretaries of the Army, Air Force, and Navy:

CARL E. VUONO
General, United States Army
Chief of Staff

Official:

THOMAS F. SIKORA
Brigadier General, United States Army
The Adjutant General

MERRILL A. McPEAK
General USAF
Chief of Staff

Official:

CHARLES C. MCDONALD
General, USAF
Commander, Air Force Logistics Command

DAVID E. BUTTORFF
Rear Admiral, CEC, US Navy
Commander
Navy Facilities Engineering Command

DISTRIBUTION:

To be distributed in accordance with DA Form 12-25E, (qty rqr block no. 0889).

CHANGE

HEADQUARTERS,
DEPARTMENT OF THE ARMY,
NAVY AND AIR FORCE
WASHINGTON, D.C., 19 October 1990

NO. 8

Operator, Organizational, Intermediate (Field)
(Direct Support and General Support),
and Depot Level Maintenance Manual

GENERATOR SET, TACTICAL, GASOLINE ENGINE, AIR COOLED,
5 KW, AC, 120/240 V SINGLE PHASE, 120/280 V 3 PHASE, SKID MOUNTED,
TUBULAR FRAME (LESS ENGINE) MILITARY DESIGN

| DOD MODEL | CLASS | HERTZ | NSN |
|-----------|---------|-------|------------------|
| MEP-017A | UTILITY | 60 | 6115-00-017-8240 |
| MEP-022A | UTILITY | 400 | 6115-00-017-8241 |

Approved for public release; distribution is unlimited

TM 5-6115-332-14/P-8-614-14/TO 35C2-3-424-1, 9 December 1977, is changed as follows:

1. Remove and insert pages as indicated below. New or changed text material is indicated by a vertical bar in the margin. An illustration change is indicated by a miniature pointing hand.

Remove pages

1-1 and 1-2
3-13 and 3-14
4-43 and 4-44
7-1 and 7-2

A-1 and A-2
C-3 and C-4
C-8

Insert pages

1-1 and 1-2
3-13 and 3-14
4-43 and 4-44
7-1 and 7-2
7-2.1/7-2.2
A-1 and A-2
C-3 and C-4
(C-7 Blank)/C-8

2. Retain this sheet in front of manual for reference purposes.

TM 5-6115-332-14
P-8-614-14
TO 35C2-3-424-1
C 8

By Order of the Secretaries of the Army , Navy, and Air Force:

CARL E. VUONO
General, United States Army
Chief of Staff

Official:

THOMAS F. SIKORA
Brigadier General, United States Army
The Adjutant General

MICHAEL J. DUGAN
General USAF
Chief of Staff

Official:

CHARLES C. MCDONALD
General, USAF
Commander, Air Force Logistics Command

DAVID E. BUTTORFF
Rear Admiral, CEC, US Navy
Commander
Navy Facilities Engineering Command

DISTRIBUTION:

To be distributed in accordance with DA Form 12-25E, (qty rqr block no. 0889)

CHANGE

No. 7

HEADQUARTERS
DEPARTMENT OF THE ARMY
Washington, D.C., 5 October 1989

Operator, Organizational, Intermediate (Field),
(Direct Support and General Support), and
Depot Level Maintenance Manual

GENERATOR SET, TACTICAL, GASOLINE ENGINE: AIR COOLED,
5 KW, AC, 120/240 V SINGLE PHASE, 120/208V 3 PHASE, SKID MOUNTED,
TUBULAR FRAME (LESS ENGINE) MILITARY DESIGN

| DOD MODEL | CLASS | HERTZ | NSN |
|-----------|---------|-------|------------------|
| MEP-017A | Utility | 60 | 6115-00-017-8240 |
| MEP-022A | Utility | 400 | 6115-00-017-8241 |

Approved for public release. Distribution is unlimited.

TM 5-6115-332-14/P-8-614-14/T.O. 35C2-3-424-1, 9 December 1977, is changed as follows:

1. Remove and insert pages as indicated below. New or changed text material is indicated by a vertical bar in the margin. An illustration change is indicated by a miniature pointing hand.

| Remove pages | Insert pages |
|---------------|---------------|
| 4-3 and 4-4 | 4-3 and 4-4 |
| 4-39 and 4-40 | 4-39 and 4-40 |
| 4-43 and 4-44 | 4-43 and 4-44 |
| ----- | 4-44.1/4-44.2 |
| 6-7 and 6-8 | 6-7 and 6-8 |
| 6-11 and 6-12 | 6-11 and 6-12 |

2. Retain this sheet in front of manual for reference purposes.

By Order of the Secretary of the Army:

CARL E. VUONO
General, United States Army
Chief of Staff

Official:

WILLIAM J. MEEHAN, II
Brigadier General, United States Army
The Adjutant General

DISTRIBUTION:

To be distributed in accordance with DA Form 12-25A, Operator, Unit, Direct Support and General Support Maintenance requirements for Generator Set, Gas Driven, Tactical, Skid Mounted, 120/240V, 1PH, 120/208V, 3PH, 5KW, (60HZ: MEP-017A; 400HZ: MEP-022A).

CHANGE }
No. 6 }

HEADQUARTERS
DEPARTMENTS OF THE ARMY,
THE NAVY AND THE AIR FORCE
WASHINGTON, D.C. 4 April 1988

Operator, Organizational, Intermediate
(Field), (Direct Support and General Support),
and Depot Level Maintenance Manual

GENERATOR SET, TACTICAL, GASOLINE ENGINE: AIR COOLED,
5 KW, AC, 120/240V SINGLE PHASE,
120/208V 3 PHASE, SKID MOUNTED,
TUBULAR FRAME (LESS ENGINE) MILITARY DESIGN

| DOD MODEL | CLASS | HERTZ | NSN |
|-----------|---------|-------|------------------|
| MEP-017A | UTILITY | 60 | 6115-00-017-8240 |
| MEP-022A | UTILITY | 400 | 6115-00-017-8241 |

TM 5-6115-332-14/P-8-614-14/T.O. 35C2-3-424-1, 9 December 1977, is changed as follows:

1. Remove and insert pages as indicated below. New or changed text material is indicated by a vertical bar in the margin. An illustration change is indicated by a miniature pointing hand.

Remove pages

a/b
iii through iv
1-3 and 1-4
1-9 through 1-12
2-11 through 2-14
2-14.1/2-14.2
2-19 and 2-20
3-3 through 3-6
3-13 and 3-14
3-37 and 3-38
4-63 and 4-64

4-67 and 4-68
5-1 and 5-2
8-1 and 8-2
A-1 and A-2
B-1 and B-2
C-3 through C-6
C-7 and C-8

Insert pages

a and b
iii through v/vi
1-3 and 1-4
1-9 through 1-12
2-11 through 2-14
2-14.1/2-14.2
2-19 and 2-20
3-3 through 3-6
3-13 and 3-14
3-37 and 3-38
4-63 and 4-64
4-64.1/4-64.2
4-67 and 4-68
5-1 and 5-2
8-1 and 8-2
A-1/A-2
B-1 and B-2
C-3 through C-6
C-8

2. Retain this sheet in front of manual for reference purposes.

TM 5-6115-332-14
P-8-614-14
TO 35C2-3-424-1
C 6

By Order of the Secretaries of the Army, the Navy, and the Air Force:

Official:

R. L. DILWORTH
Brigadier General, United States Army
The Adjutant General

CARL E. VUONO
General, United States Army
Chief of Staff

J. P. JONES, JR.
Rear Admiral, CEC, US Navy
Commander
Naval Facilities Engineering Command

Official:

EARL T. O'LOUGHLIN
General, USAF, Commander, Air Force
Logistics Command

LARRY D. WELSH, General USAF
Chief of Staff

DISTRIBUTION:

To be distributed in accordance with DA Form 12-25A, Operator, Unit, Direct Support and General Support Maintenance Requirements for Generator Set, Gas Driven, Tactical, Skid Mounted, 120/240V, 1PH, 120/208V, 3PH, 5KW, (60HZ; MEP-017A; 400HZ MEP-022A).

CHANGE }
 No. 5 }

HEADQUARTERS
 DEPARTMENTS OF THE ARMY,
 THE NAVY AND THE AIR FORCE
 WASHINGTON, D.C. 13 June 1986

Operator, Organizational, Intermediate
 (Field), (Direct Support and General Support),
 and Depot Level Maintenance Manual

GENERATOR SET, TACTICAL, GASOLINE ENGINE: AIR COOLED,
 5 KW, AC, 120/240V SINGLE PHASE,
 120/208V 3 PHASE, SKID MOUNTED,
 TUBULAR FRAME (LESS ENGINE) MILITARY DESIGN

| DOD MODEL | CLASS | HERTZ | NSN |
|-----------|---------|-------|------------------|
| MEP-017A | UTILITY | 60 | 6115-00-017-8240 |
| MEP-022A | UTILITY | 400 | 6115-00-017-8241 |

TM 5-6115-332-14/P-8-614-14/T.O. 35C2-3-424-1, 9 December 1977, is changed as follows:

- Warning page is superseded as follows.
- Remove and insert pages as indicated below. New or changed text material is indicated by a vertical bar in the margin. An illustration change is indicated by a miniature pointing hand.

| Remove pages | Insert pages |
|-------------------|------------------------|
| iii and iv | iii and iv |
| 1-1 and 1-2 | 1-1 and 1-2 |
| 2-10.1/2-10.2 | 2-10.1/2-10.2 |
| 2-13 and 2-14 | 2-13 and 2-14 |
| --- | 2-14.1/2-14.2 |
| 2-17 and 2-18 | 2-17 and 2-18 |
| 3-1 through 3-4 | 3-1 through 3-4 |
| 3-4.1/3-4.2 | 3-4.1/3-4.2 |
| 4-43 and 4-44 | 4-43 and 4-44 |
| 4-44.1/4-44.2 | --- |
| 4-45 through 4-48 | 4-45 through 4-48 |
| 4-55 through 4-68 | 4-55 through 4-68 |
| 7-3 and 7-4 | 7-3 and 7-4 |
| 7-4.3/7-4.4 | 7-4.3/7-4.4 |
| 7-5 through 7-10 | 7-5 through 7-10 |
| 7-15 and 7-16 | 7-15 and 7-16 |
| 7-21 and 7-22 | 7-21 and 7-22 |
| 7-25 through 7-27 | 7-25 through 7-27/7-28 |
| A-1 | A-1/A-2 |
| B-1 and B-2 | B-1 and B-2 |
| F0-3 | F0-3 |

- Retain this sheet in front of manual for reference purposes.

TM 5-6115-332-14
P-8-614-14
TO 35C2-3-424-1
C 5

By Order of the Secretaries of the Army, the Navy, and the Air Force:

JOHN A. WICKHAM, JR.
General, United States Army
Chief of Staff

Official:

R. L. DILWORTH
Brigadier General, United States Army
The Adjutant General

J. P. JONES, JR.
Rear Admiral, CEC, US Navy
Commander
Naval Facilities Engineering Command

CHARLES A. GABRIEL, General USAF
Chief of Staff

Official:

EARL T. O'LOUGHLIN
General, USAF, Commander, Air Force
Logistics Command

DISTRIBUTION:

To be distributed in accordance with DA Form 12-25A, Operator, Organizational, and Direct Support and General Support Maintenance Requirements for Generator Set, Gas Driven, Tactical, Skid Mounted, 120/240V, 1PH, 120/208V, 3PH, 5KW, (60HZ; MEP-017A; 400HZ MEP-022A).

CHANGE }
No. 4 }

HEADQUARTERS, DEPARTMENTS OF
THE ARMY, THE NAVY, AND THE AIR FORCE
WASHINGTON, D.C., 29 September 1985

Operator, Organizational, Intermediate
(Field), (Direct Support and General Support),
and Depot Level Maintenance Manual

GENERATOR SET, TACTICAL, GASOLINE ENGINE: AIR COOLED,
5 KW, AC, 120/240V SINGLE PHASE,
120/208V 3 PHASE, SKID MOUNTED,
TUBULAR FRAME (LESS ENGINE) MILITARY DESIGN

| DOD MODEL | CLASS | HERTZ | NSN |
|-----------|---------|-------|------------------|
| MEP-017A | UTILITY | 60 | 6115-00-017-8240 |
| MEP-022A | UTILITY | 400 | 6115-00-017-8241 |

TM 5-6115-332-14/P-8-614-14/T.O. 35C2-3-424-1, 9 December 1977, is changed as follows:

1. Remove and insert pages as indicated below. New or changed text material is indicated by a vertical bar in the margin. An illustration change is indicated by a miniature pointing hand.

Remove pages

1-11 and 1-12
3-7 and 3-8
4-41 through 4-44
4-45 and 4-46
6-11 and 6-12
C-5 and C-6

Insert pages

1-11 and 1-12
3-7 and 3-8
4-41 through 4-44
4-45 and 4-46
6-11 and 6-12
C-5 and C-6

2. Retain this sheet in front of manual for reference purposes.

TM 5-6115-332-14
P-8-614-14
T.O. 35C2-3-424-1
C 4

By Order of the Secretaries of the Army, the Navy, and the Air Force:

JOHN A. WICKHAM, JR.
General, United States Army
Chief of Staff

Official:

MILDRED E. HEDBERG
Brigadier General, United States Army
The Adjutant General

CHARLES A. GABRIEL, General USAF
Chief of Staff

Official:

EARL T. O'LOUGHLIN, General USAF
Commander, Air Force Logistics Command

J. P. JONES, JR.,
Rear Admiral, CEC, US Navy
Commander,
Naval Facilities Engineering Command

DISTRIBUTION:

To be distributed in accordance with DA Form 12-25A, Operator, Organizational, Direct Support and General Support Maintenance requirements for Generator Set, Gas Driven, Tactical, Skid Mounted, 120/240V, 1PH, 120/208V, 3PH, 5KW, (60HZ: MEP-017A; 400 HZ: MEP-022A) (TM 5-6115-332 Series).

CHANGE }
No. 3 }

HEADQUARTERS
DEPARTMENTS OF THE ARMY,
THE NAVY AND THE AIR FORCE
WASHINGTON, D.C., 8 September 1982

Operator, Organizational, Intermediate
(Field), (Direct Support and General Support),
and Depot Level Maintenance Manual

GENERATOR SET, TACTICAL, GASOLINE ENGINE: AIR COOLED,
5 KW, AC, 120/240V SINGLE PHASE,
120/208V 3 PHASE, SKID MOUNTED,
TUBULAR FRAME (LESS ENGINE) MILITARY DESIGN

| DOD MODEL | CLASS | HERTZ | NSN |
|-----------|---------|-------|------------------|
| MEP-017A | UTILITY | 60 | 6115-00-017-8240 |
| MEP-022A | UTILITY | 400 | 6115-00-017-8241 |

TM 5-6115-332-14/P-8-614-14/T.O. 35C2-3-424-1, 9 December 1977, is changed
as follows:

1. Remove and insert pages as indicated below.

| | Remove pages | Insert pages |
|------------|--------------------------------|--------------------------------|
| Chapter 1 | 1-1 and 1-2 | 1-1 and 1-2 |
| Chapter 2 | 2-11 thru 2-18 | 2-11 thru 2-18.1/2-18.2 |
| Chapter 3 | 3-3 thru 3-6 | 3-3 thru 3-6 |
| Chapter 4 | 4-37 thru 4-40 | 4-37 thru 4-40 |
| Chapter 7 | 7-4.1 and 7-4.2 7-7 and 7-8 | 7-4.1 and 7-4.2 7-7 and 7-8 |
| Appendix B | B-1 and B-2 | B-1 and B-2 |
| Appendix C | C-5 and C-6 FO-3 | C-5 and C-6 FO-3 |

2. New or changed text material is indicated by a vertical bar in the margin.
An illustration change is indicated by a miniature pointing hand.

3. Retain this sheet in front of manual for reference purposes.

TM 5-6115-332-14
P-8-614-14
T.O. 35C2-3-424-1
C 3

By Order of the Secretaries of the Army, the Navy, and the Air Force:

Official:

E. C. MEYER
General, United States Army
Chief of Staff

ROBERT M. JOYCE
Major General, United States Army
The Adjutant General

W. M. ZOBEL
Rear Admiral, CEC, US Navy
Commander
Naval Facilities Engineering Command

Official:

CHARLES A. GABRIEL, General, USAF
Chief of Staff

JAMES P. MULLINS
General, USAF, Commander, Air Force
Logistics Command

Distribution:

To be distributed in accordance with DA Form 12-25D, Operator Maintenance requirements for Engine Driven, 5KW 60HZ and 5KW 400 HZ.

CHANGE }
No. 2 }

HEADQUARTERS
DEPARTMENTS OF THE ARMY,
THE NAVY AND THE AIR FORCE
WASHINGTON, DC. 15 January 1982

Operator, Organizational, Intermediate
(Field), (Direct Support and General Support),
and Depot Level Maintenance Manual

GENERATOR SET, TACTICAL, GASOLINE ENGINE: AIR COOLED,
5 KW, AC, 120/240V SINGLE PHASE,
120/208V 3 PHASE, SKID MOUNTED,
TUBULAR FRAME (LESS ENGINE) MILITARY DESIGN

| DOD MODEL | CLASS | HERTZ | NSN |
|-----------|---------|-------|------------------|
| MEP-017A | UTILITY | 60 | 6115-00-017-8240 |
| MEP-022A | UTILITY | 400 | 6115-00-017-8241 |

TM 5-6115-332-14/P-8-614-14/T.O. 35C2-3-424-1, 9 December 1977, is changed as follows:

1. Remove and insert pages as indicated below.

| | Remove pages | Insert pages |
|-------------------|----------------------------|--|
| Table of Contents | iii and iv | iii and iv |
| Chapter 3 | 3-3 and 3-4 | 3-3 thru 3-4.1/3-4.2 |
| Chapter 4 | 4-15 and 4-16 | 4-15 and 4-16 |
| Chapter 7 | 7-3 and 7-4 7-5 and 7-6 | 7-3 thru 7-4.3/7-4.4 7-5 and 7-6 FO-5 and FO-6 |

2. New or changed text material is indicated by a vertical bar in the margin. An illustration change is indicated by a miniature pointing hand.

3. Retain these sheets in front of manual for reference purposes.

TM 5-6115-332-14
P-8-614-14
T.O. 35C2-3-424-1
C 2

By Order of the Secretaries of the Army, the Navy, and the Air Force:

Official:

ROBERT M. JOYCE
Brigadier General, United States Army
The Adjutant General

E. C. MEYER
General, United States Army
Chief of Staff

Official:

JAMES L. WYATT, JR., Colonel, USAF
Director of Administration

W. M. ZOBEL
Rear Admiral, CEC, U.S. Navy
Commander, Naval Facilities
Engineering Command

LEW ALLEN, JR., General, USAF
Chief of Staff

DISTRIBUTION:

To be distributed in accordance with DA Form 12-25D, Operator Maintenance requirements for Generator Sets, Engine Driven, 5KW 60HZ and 5KW 400HZ.

CHANGE }
NO. 1 }

HEADQUARTERS
DEPARTMENT OF THE ARMY
WASHINGTON, D.C., 11 July 1980

Operator's Organizational, Intermediate
(Field), (Direct Support and General Support),
and Depot Level Maintenance Manual

GENERATOR SET, TACTICAL, GASOLINE ENGINE: AIR COOLED,
5 KW, AC, 120/240V SINGLE PHASE,
120/208V 3 PHASE, SKID MOUNTED,
TUBULAR FRAME (LESS ENGINE) MILITARY DESIGN

| DOD MODEL | CLASS | HERTZ | NSN |
|-----------|---------|-------|------------------|
| MEP-017A | UTILITY | 60 | 6115-00-017-8240 |
| MEP-022A | UTILITY | 400 | 6115-00-017-8241 |

TM 5-6115-332-14, P-8-614-14 and TO 35C2-3-424-1, 9 December 1977, is changed as follows:

1. Remove and insert pages as indicated below.

| | Remove pages | Insert pages |
|-----------|--|--|
| Chapter 2 | 2-7 and 2-8 | 2-7 and 2-8 2-10.1/2-10.2 |
| Chapter 3 | 3-3 and 3-4 | 3-3 and 3-4 |
| Chapter 4 | 4-1 and 4-2 4-41 thru 4-44 4-45 and 4-46 | 4-1 thru 4-2.1/4-2.2 4-41 thru 4-44.1/4-44.2 4-45 and 4-46 |

2. New or changed text material is indicated by a vertical bar in the margin. An illustration change is indicated by a miniature pointing hand.

3. Retain this sheet in front of manual for reference purposes.

By Order of the Secretary of the Army:

E. C. MEYER
General, United States Army
Chief of Staff

Official:

J. C. PENNINGTON
Major General, United States Army
The Adjutant General

DISTRIBUTION:

To be distributed in accordance with DA Form 12-25D, Operator's Maintenance requirements for Generator Sets, Engine Driven, 5 KW 60 HZ and 5 KW 400 HZ.

TECHNICAL MANUAL

NO. 5-6115-332-14

HEADQUARTERS
DEPARTMENTS OF THE ARMY, THE NAVY AND THE AIR FORCE
WASHINGTON, D.C., 9 December 1977

OPERATOR, ORGANIZATIONAL, INTERMEDIATE (FIELD),
(DIRECT SUPPORT AND GENERAL SUPPORT), AND DEPOT LEVEL
MAINTENANCE MANUAL

**GENERATOR SET, TACTICAL, GASOLINE ENGINE: AIR COOLED,
5 KW, AC, 120/240V SINGLE PHASE,
120/208V 3 PHASE, SKID MOUNTED,
TUBULAR FRAME (LESS ENGINE) MILITARY DESIGN**

| DOD MODEL | CLASS | HERTZ | NSN |
|-----------|---------|-------|------------------|
| MEP-017A | UTILITY | 60 | 6115-00-017-8240 |
| MEP-022A | UTILITY | 400 | 6115-00-017-8241 |

REPORTING ERRORS AND RECOMMENDING IMPROVEMENTS

You can help improve this manual. If you find any mistakes, or if you know of a way to improve these procedures, please let us know. Mail your letter or DA Form 2028 (Recommended Changes to Publications and Blank Forms), or DA Form 2028-2 located in the back of this manual directly to: Commander, US Army Aviation and Troop Command, ATTN: AMSAT-I-MP, 4300 Goodfellow Blvd., St. Louis, MO 63120-1798. You may also submit your recommended changes by E-mail directly to <mpmte/oavma2.8st-louis-emh7.army.mil>. A reply will be furnished directly to you. Instructions for sending an electronic 2028 may be found at the back of this manual immediately preceding the hard copy 2028.

DISTRIBUTION STATEMENT A: Approved for public release; distribution is unlimited

TABLE OF CONTENTS

| | PAGE |
|--|-------------|
| CHAPTER 1 INTRODUCTION | |
| Section I General | 1-1 |
| Section II Description and Data | 1-3 |
| CHAPTER 2 OPERATING INSTRUCTIONS | |
| Section I Operating Procedures..... | 2-1 |
| Section II Operation of Auxiliary Equipment | 2-17 |
| Section III Operation Under Unusual Conditions | 2-19 |
| CHAPTER 3 OPERATOR/CREW MAINTENANCE INSTRUCTIONS | |
| Section I Consumable Operating and Maintenance Supplies | 3-1 |
| Section II Lubrication Instructions | 3-3 |
| Section III Preventive Maintenance Checks and Services (PMCS)..... | 3-3 |
| Section IV Troubleshooting | 3-5 |
| Section V Operator/Crew Maintenance Instructions | 3-13 |

This manual supersedes TM 5-6115-332-12, dated 12 August 1970 and TM 5-6115-332-34, dated 10 August 1970.

| | | |
|--------------|--|------|
| CHAPTER 4 | ORGANIZATIONAL MAINTENANCE INSTRUCTIONS | |
| Section I | Service Maintenance Instructions..... | 4-1 |
| Section II | Movement to a New Worksite..... | 4-12 |
| Section III | Repair Parts, Special Tools and Equipment | 4-13 |
| Section IV | Lubrication Instructions | 4-14 |
| Section V | Preventive Maintenance Checks and Services (PMCS) | 4-15 |
| Section VI | Troubleshooting | 4-17 |
| Section VII | Radio Interference Suppression | 4-41 |
| Section VIII | Maintenance of the Engine Electrical System | 4-42 |
| Section IX | Maintenance of the Generator Electrical System | 4-52 |
| Section X | Maintenance of the Frame Assembly | 4-64 |
| CHAPTER 5 | INTERMEDIATE (FIELD), (DIRECT AND GENERAL SUPPORT) AND DEPOT MAINTENANCE INSTRUCTIONS | |
| Section I | Repair Parts, Special Tools and Equipment | 5-1 |
| Section II | Direct Support and General Support Troubleshooting | 5-1 |
| Section III | General Maintenance | 5-8 |
| CHAPTER 6 | REMOVAL AND INSTALLATION OF MAJOR COMPONENTS | |
| CHAPTER 7 | MAINTENANCE OF THE GENERATOR SET | |
| Section I | Control Box Assembly | 7-1 |
| Section II | Maintenance of the Generator | 7-12 |
| Section III | Maintenance of the Frame Assembly | 7-24 |
| CHAPTER 8 | GENERATOR SET TEST AND INSPECTION AFTER REPAIR AND OVERHAUL | |
| Section I | General Requirements | 8-1 |
| Section II | Inspection | 8-1 |
| Section III | Operational Tests .. | 8-1 |
| APPENDIX A | REFERENCES | A-1 |
| APPENDIX B | BASIC ISSUE ITEMS LIST AND ITEMS TROOP INSTALLED OR AUTHORIZED LIST | B-1 |
| APPENDIX C | MAINTENANCE ALLOCATION CHART (FOR ARMY AND MARINE CORPS ONLY)..... | C-1 |

List of Illustrations

| Figure | Title | Page |
|---------------|--|-------------|
| 1-1. | Generator Set, Left Rear, Three-Quarter View (Model MEP-017A, 60 Hertz) | 1-3 |
| 1-2. | Generator Set, Right Front, Three-Quarter View (Model MEP-017A, 60 Hertz) | 1-4 |
| 1-3. | Generator Set, Left Rear, Three-Quarter View (Model MEP-022A, 400 Hertz) | 1-5 |
| 1-4. | Generator Set, Right Front, Three-Quarter View (Model MEP-022A, 400 Hertz) | 1-6 |
| 1-5. | Base Plan | 1-8 |
| 1-6. | Wiring Diagram | 1-11 |
| 1-7. | Panel A Wiring Diagram (MEP-017A) | 1-12 |
| 2-1. | Fuel Selector Valve | 2-2 |
| 2-2. | Choke Control Governor Control and Air Cleaner Intake Shutter | 2-2 |
| 2-3. | Generator Control Panel, Controls, Instruments and Panel Lights | 2-4 |
| 2-4. | Output Selector Switch | 2-6 |
| 2-5. | Generator Field Flash Switch | 2-7 |
| 2-6. | Generator Frequency Meter (Model MEP-022A) | 2-8 |
| 2-7. | Electric Starting Instructions, Local Mode | 2-12 |
| 2-8. | Manual Starting Instructions. | 2-14 |
| 2-9. | Remote Control Terminals | 2-15 |
| 2-10. | Stopping Instructions, Local Mode | 2-16 |
| 2-11. | Blowtorch Operation and Service Instructions | 2-18 |
| 3-1. | Battery Cables, Starter Cable and Grommet and Terminal Stud | 3-7 |
| 3-2. | Fuses, Removal and Installation (Model MEP-017A) | 3-10 |
| 3-3. | Panel Light Lamp, Removal and Installation | 3-12 |
| 3-4. | Fuel Can, Removal and Installation | 3-14 |
| 4-1. | Revetment, Top Plan View.. | 4-5 |
| 4-2. | Revetment, Side Plan View. | 4-6 |
| 4-3. | Revetment, Isometric Plan View | 4-6 |
| 4-4. | Revetment, Perspective Without Roof | 4-7 |
| 4-5. | Revetment, Front View.... | 4-8 |
| 4-6. | Revetment, Left Side View. | 4-9 |
| 4-7. | Revetment, Exhaust Piping | 4-10 |
| 4-8. | Types of Multimeters | 4-18 |
| 4-9. | “Zeroing” the Multimeters (Sheet 1 of 3) | 4-20 |
| 4-9. | “Zeroing” the Multimeters (Sheet 2 of 3) | 4-21 |
| 4-9. | “Zeroing” the Multimeters (Sheet 3 of 3) | 4-22 |
| 4-10. | TS 352 Continuity Test.... | 4-23 |
| 4-11. | Testing for Shorts | 4-24 |
| 4-12. | Testing Resistance | 4-25 |
| 4-13. | Reading the OHM Scale | 4-26 |
| 4-14. | DC Volts Scale (Sheet 1 of 3).... | 4-27 |
| 4-14. | DC Volts Scale (Sheet 2 of 2).... | 4-28 |
| 4-14. | DC Volts Scale (Sheet 3 of 3) | 4-29 |
| 4-15. | Measuring DC Voltage | 4-30 |
| 4-16. | Reading DC Voltage (Sheet 1 of 3) | 4-31 |
| 4-16. | Reading DC Voltage (Sheet 2 of 3) | 4-31 |
| 4-16. | Reading DC Voltage (Sheet 3 of 3) | 4-32 |
| 4-17. | AC Volt Scale (Sheet 1 of 3)..... | 4-33 |
| 4-17. | AC Volt Scale (Sheet 2 of 3) | 4-34 |
| 4-17. | AC Volt Scale (Sheet 3 of 3) | 4-35 |
| 4-18. | Measuring AC Voltage | 4-36 |
| 4-19. | Reading AC Voltage | 4-37 |

List of Illustrations

| Figure | Title | Page |
|--------|---|------|
| 4-20. | Replacement of Radio Interference Suppression Components | 4-41 |
| 4-21. | Battery Cables, Starter Cable and Grommet and Terminal Stud, Removal and Installation | 4-43 |
| 4-22. | Battery and Battery Frame, Removal and Installation | 4-45 |
| 4-23. | Slave Receptacle and Bracket, Removal and Installation | 4-47 |
| 4-24. | Control Panel Controls, Instruments and Panel Lights, Removal and Installation | 4-49 |
| 4-25. | Fuseholder, Removal and Installation (Model MEP-017A) | 4-55 |
| 4-26. | Circuit Breaker, Removal and Installation | 4-56 |
| 4-27. | Control Relays, Removal and Installation | 4-57 |
| 4-28. | Relay, Internal Connection Diagram | 4-58 |
| 4-29. | Outlet Receptacle (J1)(Model MEP-017A) | 4-60 |
| 4-30. | Top Resilient Mounts, Removal and Installation | 4-61 |
| 4-31. | Toolbox, Removal and Installation | 4-62 |
| 4-32. | Control Box Bracket, Removal and Installation | 4-63 |
| 4-33. | Guard Frame, Removal and Installation | 4-64 |
| 4-34. | Lifting Eye and Lifting Bracket, Removal and Installation | 4-66 |
| 4-35. | Ground Terminal Stud Removal and Installation | 4-67 |
| 6-1. | Control Box, Removal and Installation | 6-1 |
| 6-2. | Generator, Removal and Installation (Model MEP-017A) | 6-3 |
| 6-3. | Generator, Removal and Installation (Model MEP-022A) | 6-6 |
| 6-4. | Fuel Hoses, Removal and Installation | 6-9 |
| 6-5. | Starter Cable, Removal | 6-10 |
| 6-6. | Engine, Removal and Installation. | 6-11 |
| 7-1. | Control Box Components, Removal and Installation | 7-2 |
| 7-2. | Voltage Regulator, Removal and Installation | 7-5 |
| 7-3. | Voltage Regulator, Removal and Installation | 7-6 |
| 7-4. | Voltage Regulator, Removal and Installation | 7-7 |
| 7-5. | Load Terminal Board, Removal and Installation | 7-8 |
| 7-6. | Remote Control Terminal Board, Removal and Installation (TB3) | 7-9 |
| 7-7. | Terminal Board, Removal and Installation (TB2) | 7-11 |
| 7-8. | Main Generator Stator and Housing Assembly, Disassembly (Model MEP-017A) | 7-13 |
| 7-9. | Main Generator Stator and Housing Assembly, Disassembly (Model MEP-022A) | 7-15 |
| 7-10. | Exciter Field Frame Assembly, Repair | 7-17 |
| 7-11. | Alternator Stator, Repair | 7-18 |
| 7-12. | Main Generator Rotor, Assembly, Disassembly (Model MEP-017A) | 7-20 |
| 7-13. | Main Generator Rotor Assembly, Disassembly (Model MEP-022A) | 7-21 |
| 7-14. | Exciter Rotor, Test | 7-22 |
| 7-15. | Alternator Rotor Assembly Test. | 7-23 |
| 7-16. | Engine Support and Drip Pan, Removal and Installation | 7-25 |
| 7-17. | Fuel Can Brackets, Removal and Installation | 7-26 |
| FO-1. | Wiring Diagram (Model MEP-017A). | |
| FO-2. | Generator Set, Schematic Diagram (Model MEP-017A) | |
| FO-3. | Wiring Diagram (Model MEP-022A) | |
| FO-4. | Generator Set, Schematic Diagram (Model MEP-022A) | |

List of Tables

| Table | Title | Page |
|--------------|---|-------------|
| 1-1. | Operational and Organizational Tabulated Data | 1-9 |
| 1-2. | Direct Support and General Support Tabulated Data | 1-13 |
| 2-1. | Controls and Instruments | 2-9 |
| 2-2. | Voltmeter Indications | 2-10.1 |
| 3-1. | Consumable Maintenance and Operating Supplies | 3-2 |
| 3-2. | Operator/Crew Preventive Maintenance Checks and Services | 3-4 |
| 3-4. | Troubleshooting | 3-6 |
| 4-1. | Output Selector Switch Positions and Load Cable Connections | 4-3 |
| 4-2. | Preventive Maintenance Checks and Services | 4-16 |
| 4-3. | Organizational Troubleshooting | 4-38 |
| 5-1. | Direct Support and General Support Troubleshooting | 5-2 |
| 8-1. | Visual and Operational Inspection | 8-2 |

WARNING

All cautions and warnings contained in this manual should be strictly adhered to. Otherwise, severe injury, death and/or damage to the equipment may result.

WARNING**HIGH VOLTAGE**

is used in the operation of this equipment.

DEATH ON CONTACT

may result if personnel fail to observe safety precautions. Learn the areas containing high-voltage in each piece of equipment. Be careful not to contact high-voltage connections when installing or operating this equipment. Before working on the equipment, stop the generator set.

WARNING

When servicing the battery, do not smoke or use an open flame in the vicinity. Slave receptacle is to be used when extra cranking power is required for starting unit. Other methods are not authorized. Use extreme care when handling electrolyte. Do not operate the generator set in an enclosed building unless the exhaust gases are piped to the outside. Carbon-monoxide fumes are colorless, odorless and deadly gas. These gases could cause permanent brain damage or death, if highly concentrated in any certain area. The symptoms are headache, dizziness, loss of muscular control, apparent drowsiness and coma. If exposure symptoms exist, move afflicted person or personnel to properly ventilated area and provide artificial respiration, if necessary.

WARNING

If generator set is shut down by the operation of a safety device, do not attempt to operate unit until the cause has been determined.

WARNING

Operating noise level of this equipment can cause hearing damage. Ear protection as recommended by the medical or safety officer must be worn when working near this equipment.

WARNING

Before starting engine or operating any of the components insure that no loose bars, tools, or parts are lying in or on any part of the equipment, as they could cause serious damage to equipment or bodily injury to personnel. Never wear loose clothing, or hanging appendages from person or clothing, while inspecting running engine, moving shafts, or like machinery. Disconnect the spark plug cables prior to engine maintenance to prevent accidental starting and severe shock. Before starting engine, insure that all operating levers and controls are in proper operating positions and the engine units are properly supported. Failure to do these could result in damage to the engine, and equipment. Always provide metal-to-metal contact between fuel container and fuel tank, while refueling, to avoid igniting fuel vapors with a static spark. Before refueling, insure that adequate fire fighting equipment is serviceable and is standing by for immediate use in event of fire or explosion. During engine operation, proper fire fighting equipment should be serviceable and kept near in the event that fire is developed by electrostatic spark or detonation of the gas fumes. Do not smoke or use an open flame in vicinity of these gasoline vapor hazards. Do not refuel while engine is in operation. Do not touch the ignition system harness during starting or while in operation. Severe shocks or burns could result, and personnel maybe severely injured. Never touch engine or engine accessories with bare hands during operation, or before they have cooled sufficiently. Severe burns can be caused through carelessness.

WARNING

Clean all parts in a well-ventilated area. Avoid inhalation of solvent fumes and prolonged exposure of skin to cleaning solvent. Wash exposed skin thoroughly. Dry cleaning solvent (Fed. Spec. P-D-680 Type II) used to clean parts is potentially dangerous to personnel and property. Do not use near open flame or excessive heat. Flash point of solvent 140°F (60 °C).

WARNING

■ Serious eye injury can result from the starter rope knot. Wear eye protection when pull starting engine.

CHAPTER 1
INTRODUCTION

SECTION I. GENERAL

1-1. Scope

a. This manual is for your use in operating and maintaining the Military Designed DOD Models MEP-017A and MEP-022A Generator Sets. Information is provided on the operation, preventive maintenance checks and services, troubleshooting, operator/crew, organizational, Intermediate (Field), (Direct Support and General Support) and Depot Maintenance

b. This manual is primarily concerned with the operation and maintenance of the generator sets less engine. However, where it becomes necessary for understanding, portions of the maintenance and operation instruction which apply to the engine are included. For complete maintenance information on the engine, refer to the engine manuals in Appendix A.

c. Appendix A contains a list of reference publications applicable to this manual. Appendix B contains the Basic Issue Items List and Items Troop Installed or Authorized List. Appendix C contains the Maintenance Allocation Chart (MAC), which determines the level of maintenance responsibility for Army and Marine Corps users

1-2. Limited Applicability

Some portions of this publication are not applicable to all services. These portions are prefixed to indicate the services to which they pertain, (A) for Army, (F) for Air Force (N) for Navy and (MC) for Marine Corps. Portions not prefixed are applicable to both services.

1-3. Maintenance Forms and Records

a. This technical manual is used by the Army, Air Force, Navy and Marine Corps. The use of forms in compliance with directives as stated herein will be accomplished only by the personnel of the Service to which they apply.

b. (A) Forms and records used by the Army and prescribed by DA PAM 738-750 are as follows:

(1) DA Form 2408 (Equipment Log Assembly Records)

(2) DA Form 2408-1 (Equipment Daily and Monthly Log).

(3) DA Form 2408-5 (Equipment Modification Record)

(4) DA Form 2408-9 (Equipment Control Record).

(5) DA Form 2408-10 (Equipment Component Register)

(6) DA Form 2408-14 (Uncorrected Fault Record).

c. (F) Maintenance forms and records used by Air Force personnel are prescribed in AFM-66-1 and the applicable 00-20 Series Technical Orders.

d. (MC) Those used by the Marine Corps will be those prescribed by TM 4700-15/1

e. (N) Navy users should refer to appropriate specification/publications for equipment maintenance forms and records

1-4. Reporting of Errors

a. Reporting of errors, omissions, and recommendations for improvement of this publication by the individual user is encouraged. Response should be submitted as follows:

(1) (F) Air Force. AFTO Form 22 in accordance with T.O. 00-5-1, direct to: Commander, Sacramento Air Logistics Center, ATTN: SM-ALC-MMEDTA, McClellan Air Force Base, CA 95652-5609.

(2) (A) Army. DA Form 2028 (Recommended Changes to Publications, and Blank Forms), or DA Form 2028-2 located in the back of this manual direct to: Commander, U.S. Army Aviation and Troop Command, ATTN: AMSAT-I-MP, 4300 Goodfellow Boulevard, St. Louis, MO 63120-1798. A reply will be furnished directly to you.

(3) (N) Navy. Letter, direct to: Commanding Officer, Naval Construction Battalion Center, ATTN: Code 15741, Port Hueneme, CA 93043-5000.

(4) (MC) Marine Corps. NAVMC Form 10772 direct to: Commandant, U.S. Marine Corps Logistic Base, ATTN: Code 850, Albany, GA 31704-5000.

b. (A) Applicable Army Forms, excluding Standard Form 46 (United States Government Motor Vehicles Operator's Identification Card) which is carried by the operator, shall be kept in manual compartment mounted on equipment.

1-5. Levels of Maintenance Accomplishments

a. (A,MC) Army and Marine Corps users shall refer to the Maintenance Allocation Chart (MAC) for tasks and levels of maintenance to be performed.

b. (F) Air Force users shall accomplish maintenance at the user level consistent with their capability in accordance with policies established in AFM 66-1.

c. (N) Navy users shall determine their maintenance levels in accordance with their service directives.

1-6. (A, MC) Destruction of Materiel To Prevent Enemy Use

a. Fire. Use fire to destroy equipment when quantities of fuel and flammable materials are at hand. Burn assemblies and components on a priority basis, if possible. Proper concentration of equipment to be burned will produce a hotter, more destructive fire. Fires should be lit after mechanical destruction has been accomplished.

b. Gunfire. Fire on equipment with the heaviest weapons available aiming at the major assemblies and controls. Continue fire until the equipment is completely destroyed.

c. Mechanical Destruction. Using an axe, pick, mattock, sledge or any other heavy implements, damage or destroy all vital elements such as controls, and any other major assemblies and components.

d. For further information, refer to TM 750-244-3 (Procedures for Destruction of Equipment to Prevent Enemy Use for U.S. Army).

1-7. Administrative Storage

If the generator sets must be placed in administrative storage, proceed as follows:

a. (A) Army.

(1) Store equipment so as to provide maximum protection from the elements and to provide access for inspection, maintenance, and exercising. Anticipate removal or deployment problems and take suitable precautions. For example, strategically locate recovery vehicles, snowplows, slave-units, and similar items, likely to be needed on short notice.

(2) Take into account environmental conditions, such as extreme heat or cold; high humidity; blowing sand, dust, or loose debris; soft ground; mud; heavy snows; earthquakes; or combinations thereof and take adequate precautions.

(3) Establish a fire plan and provide for adequate fire fighting equipment and personnel.

(4) For further information, refer to TM 740-90-1 (Administrative Storage).

b. (AF) Air Force. Refer to TO 35-1-4 (Processing and Inspection of Aerospace Ground Equipment).

c. (MC) Marine Corps. Refer to MCO-P4450-7.

1-8. Preparation For Shipment and Storage

a. (A) Army. Shipment and storage for U.S. Army will be in accordance with the following:

(1) Select the best available site for administrative storage. Separate stored equipment from equipment in use. Conspicuously mark the area "Administrative Storage."

(2) Covered space is preferred. When sufficient covered space for all items to be stored is not available, priority should be given to items which are most susceptible to deterioration from the elements.

(3) Open site should be improved hardstand, if available. Unimproved sites should be firm, well drained, and kept free of excessive vegetation.

(4) Truck, vans, Conex containers, and other containers may be used if they provide the best available protection.

(5) Prior to storage, perform the next scheduled major preventive maintenance service.

(6) For further information, refer to TB 740-97-2 (Preservation of USATSARCOM Mechanical Equipment for Shipment and Storage).

b. (F) Air Force. Reference TO 35-1-4 for end item generator set and TO 38-1-5 for installed engine.

c. (N, MC) Navy and Marine Corps. Reference individual service directives for requirements.

d. Placement of equipment in administrative storage should be for short periods of time when a storage of maintenance effort exists. Items should be in mission readiness within 24 hours or within the time factors are determined by the directing authority. During the storage period appropriate maintenance records will be kept.

e. Before placing equipment in administrative storage, current maintenance services and equipment serviceable criteria (ESC) evaluations should be corrected and all modification work orders (MWO's) should be applied.

f. Storage site selection. Inside storage is preferred for items selected for administrative storage. If inside storage is not available, trucks, vans, conex containers and other containers may be used.

Section II. DESCRIPTION AND DATA

1-9. Description

a. General. The Department of Defense generator sets, DOD model MEP-017A (fig. 1-1 and 1-2) and DOD model MEP-022A (fig. 1-3 and 1-4) are powered

by a gasoline-fueled, 10-horsepower, Military Standard Engine, either the Model 2A042-2 or the Model 2A042-3. The engine is directly coupled to the generator.

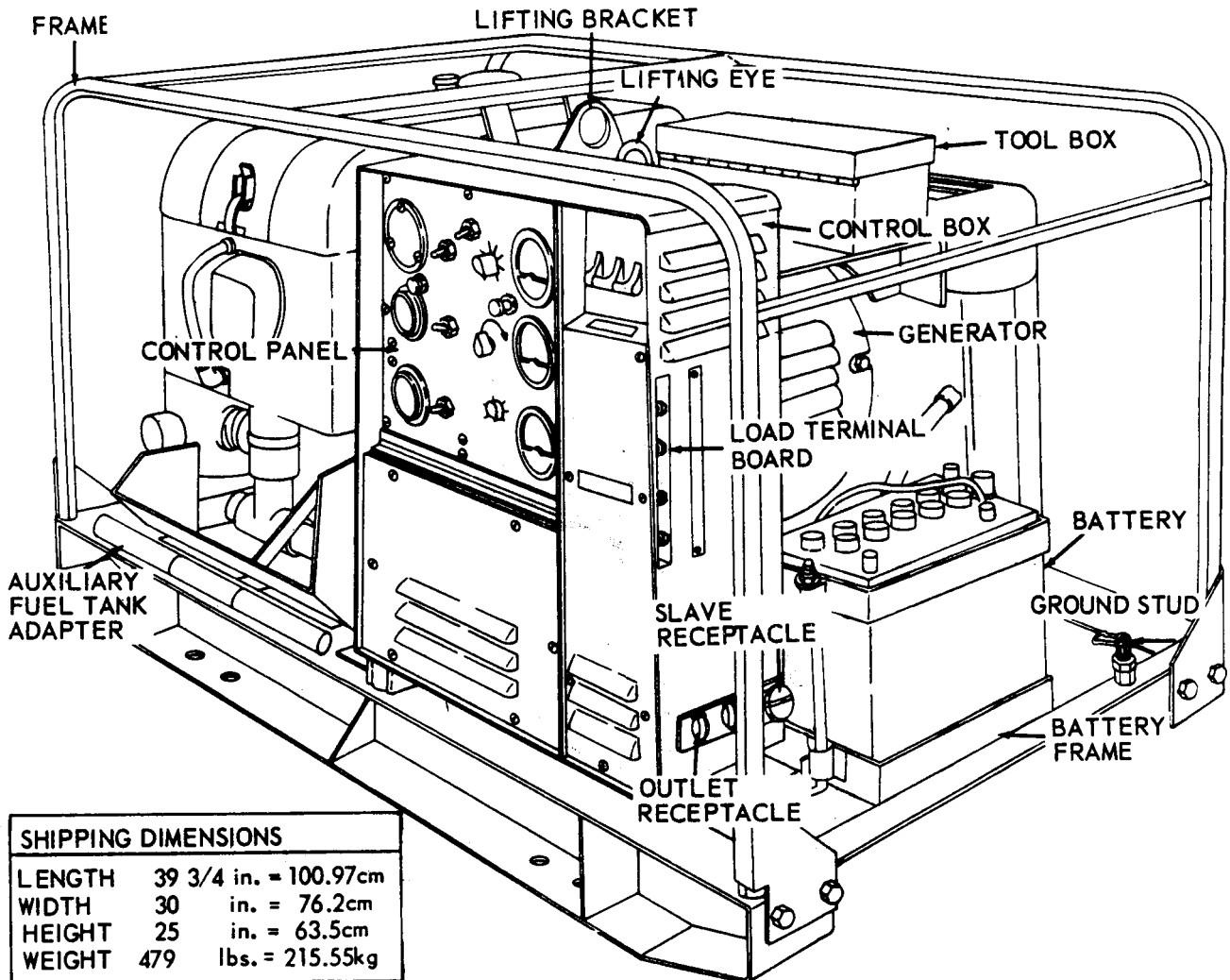

Figure 1-1. Generator set, left rear, three-quarter view (Model MEP-017A, 60 Hertz)

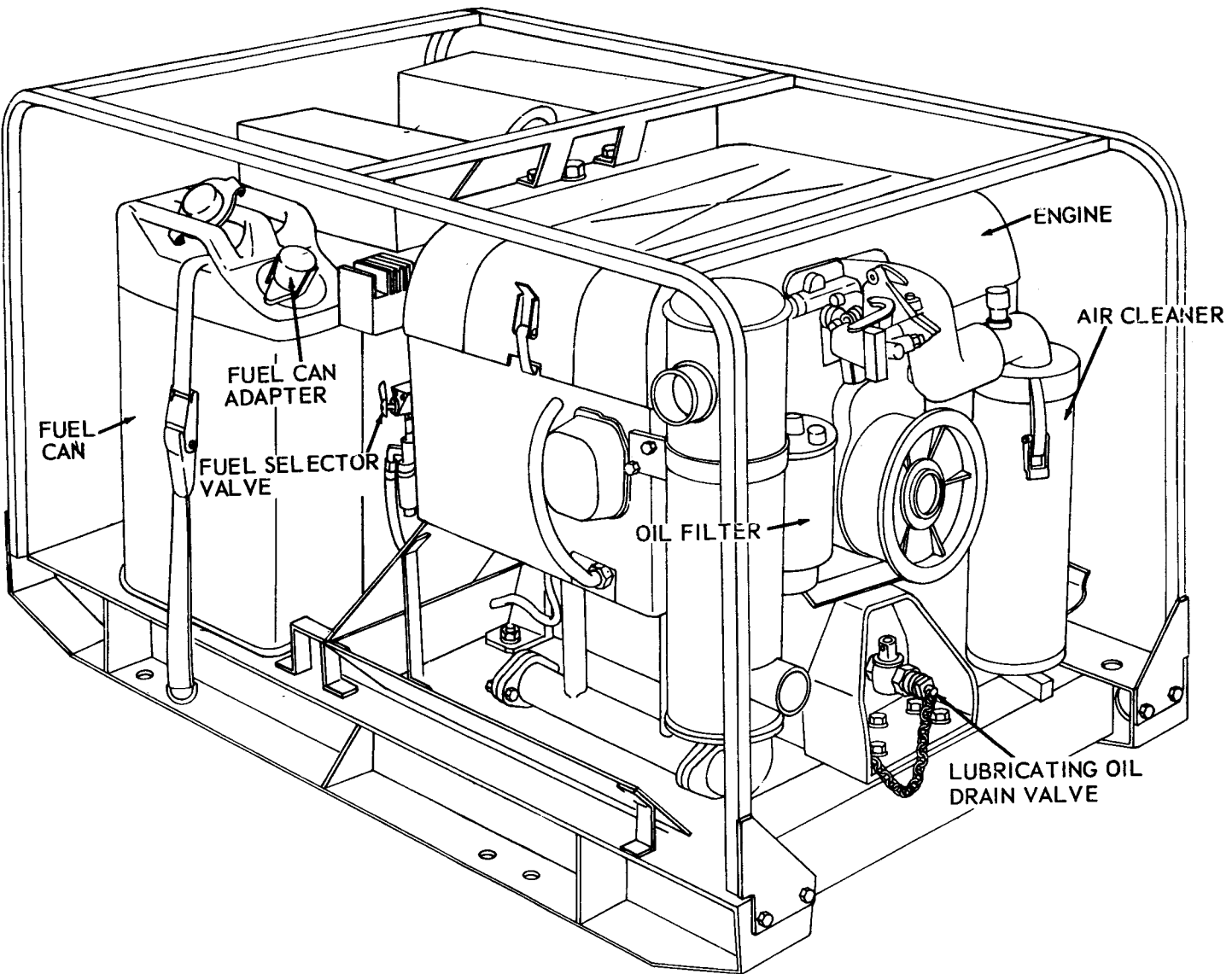
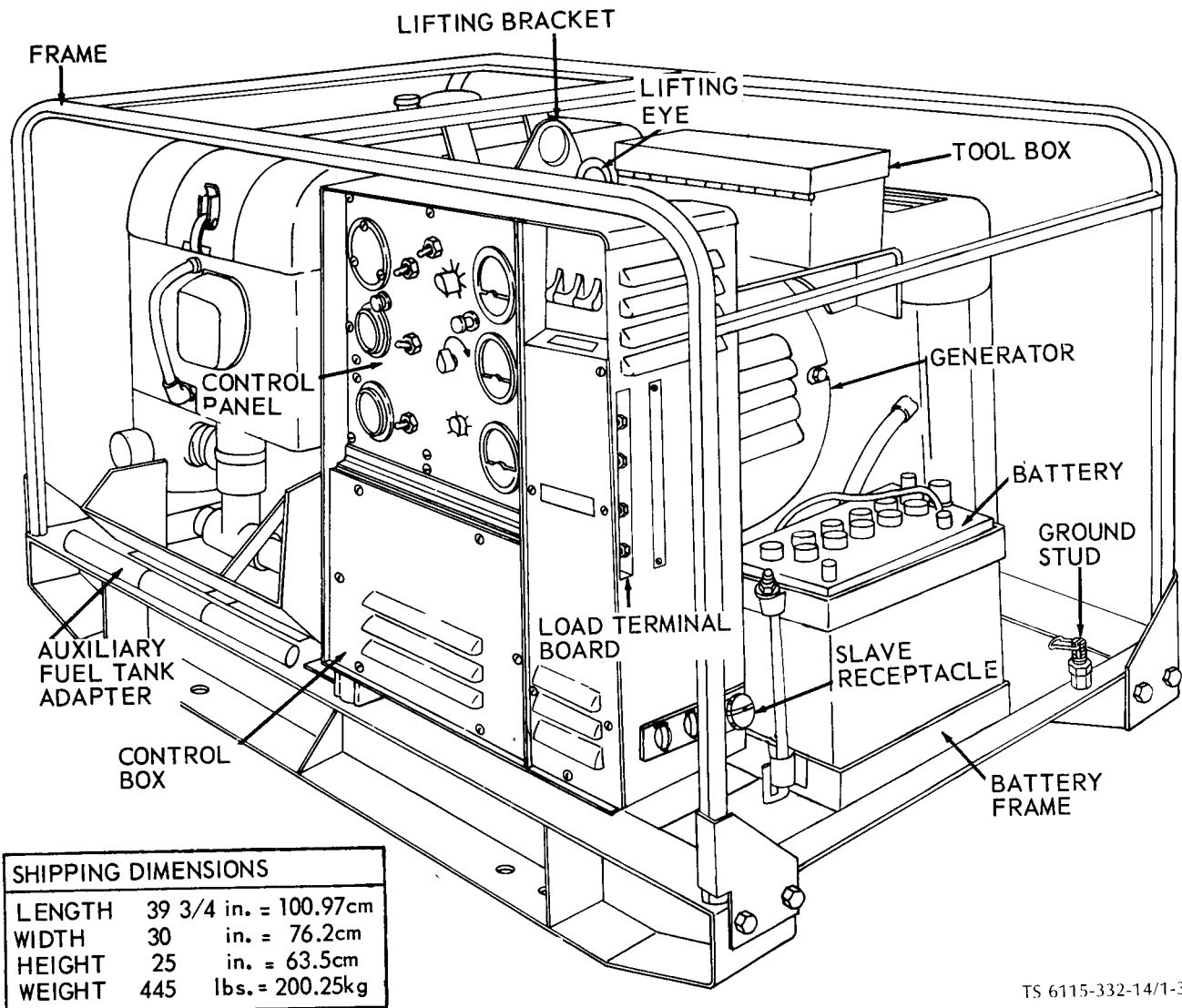
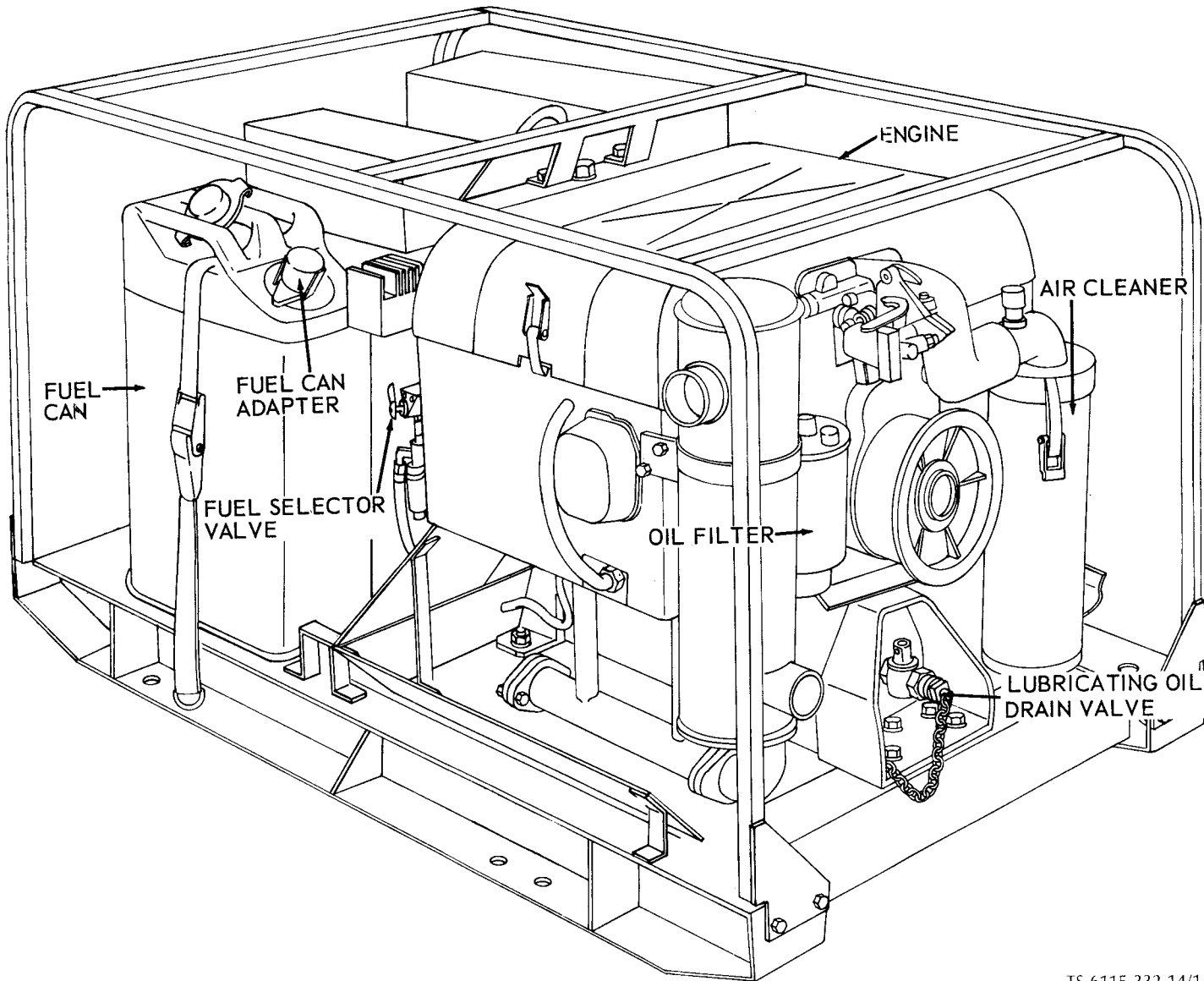

Figure 1-2. Generator set, right front, three quarter view (Model MEP-017A, 60 Hertz)



TS 6115-332-14/1-3

Figure 1-3. Generator set, left rear, three-quarter view (Model MEP-022A, 400 Hertz)



TS 6115-332-14/1-4

Figure 1-4. Generator set, right front, three-quarter view (Model MEP-022A, 400 Hertz)

b. Engines. For description of the Military Standard Engines refer to TM 5-2805-258-14.

c. Generators.

(1) Generator Set Model MEP-017A. The generator (fig. 1-1) provided with the Model MEP-017A generator set has a 2-pole rotor with a brushless rotating exciter rotor section mounted on the same shaft. The generator is rated at 5 kw (kilowatts), 0.8 pf (power factor), 60 HZ (hertz) at 3,600 rpm (revolutions per minute). The generator output characteristics are as follows: 120/240 volts, single phase, two wire; 120 volts, three phase, three wire; and 120/208 volts, three phase, four wire.

(2) Generator Set Model MEP-022A. The generator (fig. 1-3) provided with the model MEP-022A generator set has a 14-pole rotor with a brushless rotating exciter rotor section mounted on the same shaft. The generator is rated at 5 kw, 0.8 pf, 400 hz at a speed of approximately 3428 rpm. The generator output characteristics are as follows: 120/240 volts, single phase, two wire; 120 volts, three phase, three wire; and 120/208 volts, three phase, four wire.

d. Control Boxes. The control box for each of the generator sets is similar. They contain the necessary controls, instruments and other electrical components that are required for operation of the electrical portion of the generator sets.

1-10. Tabulated Data

a. Identification. The generator sets are provided with three identification plates. The information contained on these plates and their location is as follows:

(1) U.S. Army Identification Plate. This plate is located on the top of the control box bracket near the tool box. It specifies:

Generator set model number.

Stock No. (number).

Generator set serial No.

Mfr. (manufacturer).

Generator model number.

Operating volts, ph (phase) amp (amperes)

kw kilowatts), kva (kilovolt-amperes), pf

(power factor), cy (cycles) or hz (hertz) and rpm (revolutions per minute). Cont. No. (contract number).

Lg (length), width, hgt (height), and wt (weight). Eng mfg (engine manufacturer) model, and ser No.

(2) Generator Nameplate. The plate is located on the right side of the generator stator housing at a point above the support bracket. It specifies:

NSN (National stock number)

KW (kilowatts).

Cps or Hz (cycles per second or hertz).

PF (power factor).

Mfr (manufacturer).

Serial No. (number).

(3) Engine Nameplate. The engine plate is located on the upper side of the flywheel housing. It contains information on the manufacturer, model, nomenclature, National stock number and displacement.

b. Wiring Diagram. Refer to figure FO-1 and FO-2 for the wiring diagram for the Model MEP-017A generator set and to figure FO-3 and FO-4 for the wiring diagram for the Model MEP-022A generator set.

c. Engine Electrical System. The engine electrical system functions in conjunction with several of the generator set controls and other components. The system is of the 24-volt, negative, ground-type.

d. Dimensions and Weight.

(1) Model MEP-017A. For dimensions and weight, refer to figure 1-1.

(2) Model MEP-022A. For dimensions and weight, refer to figure 1-3.

e. Base Plan. The base plan provides dimensions for a base that may be prepared in advance of the installation of the generator set. The base may be constructed of wood planking or a concrete pad may be prepared, as desired. For the base plan, refer to figure 1-5.

TM 5-6115-332-14
P-8-614-14
TO 35C2-3-424-1

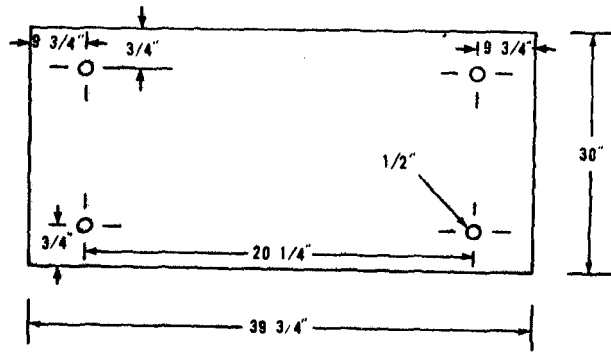

$9 \frac{3}{4} = 24.77 \text{ cm}$
 $3 \frac{3}{4} = 1.91 \text{ cm}$
 $1 \frac{1}{2} = 1.27 \text{ cm}$
 $30 = 76.2 \text{ cm}$
 $20 \frac{1}{4} = 51.44 \text{ cm}$
 $39 \frac{3}{4} = 100.97 \text{ cm}$

TS 6115-332-14/1-5

Figure 1-5. Base plan.

f. Data. Refer to Table 1-1 for Operator and Organizational Data, and to Table 1-2 for Direct Support and General Support data.

Table 1-1 Operational and Organizational Tabulated Data

1. Generator Set, 60 HZ Unit, NSN 6115-00-017-8240.

| | |
|-----------------------|--|
| Contract Numb | DS400-71-C-4381, serial number range FA71-00001 through FA71-01093 |
| Manufacturer | Onan, Division of Studebaker Corporation |
| DOD Model MEP-017A | Formerly, Onan Model 5GF-8XR/3100 and Military Design Model SF-5.-MD |
| Part Number | MERDC 13211E6695 |
| National stock number | 6115-00-017-8240, formerly 6115-00-074-8830 |
| Specification | MIL-G-52279C, formerly MIL-G-52279-B(ME) |
| Contract number | DA11-184-AMC-71 |
| Serial number range | EA-63-00001 through EA-63-06500 |
| Contract number | DA23-195-AMC-00432 |
| Serial number range | EA-66-00001 through EA-66-05242 |
| Contract number | DAAK01-67-C-0899 |
| Serial number range | EA-67-01001 through EA-67-06000 |
| Contract number | DAAK01-68-C-8051 |
| Serial number range | EA-68-00001 through EA-68-09129 |
| Manufacturer | Fermont Division of Dynamics Corporation of America |
| DOD Model MEP-017A | Formerly, Fermont Model J-117 and Military Design Model SF-5.-MD |
| Part number | MERDC 13211E6695 |
| National stock number | 6115-00-017-8240, formerly 6115-00-999-7291 |
| Specification | MIL-G-52279C, formerly MIL-G-55279-B(ME) |
| Contract number | DA-23-195-AMC-00201 |
| Serial number range | FA-65-00001 through FA-65-01469 |
| | FA-66-00001 through FA-66-01200 |
| | FA-67-00001 through FA-67-01469 |

2. Generator Set, 400 HZ, Unit, NSN 6115-00-017-8241.

| | |
|-----------------------|--|
| Manufacturer | Onan, Division of Studebaker Corporation |
| DOD Model MEP-022A | Formerly, Onan Model 5GFE-408XR/3101A and Military Design Model HS-5.-MD |
| Part number | MERDC 13212E8925 |
| National stock number | 6115-00-017-8241, formerly 6115-00-930-4816 |
| Specification | MIL-F-52279C, formerly MIL-G-52419 (MO) |
| Contract number | DA-23-195-AMC-00738 |
| Serial number range | EB-66-00001 through EB-66-00392 |

TM 5-6115-332-14
P-8-614-14
TO 35C2-3-424-1

Contract number DAAK01-68C-8051
Serial number range EB-68-00001 through EB-68-00290

3. Generator Assembly, 60 Hertz (Model MEP-017A)

Voltages 120/240 1 phase or 120/208 3phase
Amperes 52 at 120 volts, 1 phase; 26 at 240 volts, 1 phase;
30/17.3 at 120-208 volts, 3 phase, 3 wire; and 30 at 120
volts, 3 phase, 4 wire
Kilowatts 5
Kilovolt amperes 6.25
Hertz 60
Power factor 0.8
Phases 1 and 3
RPM 3,600

4. Generator Assembly, 400 Hertz (Model MEP-022A).

Voltages 120/240 1 phase or 120/208 3 phase
Amperes 52 at 120 volts, 1 phase; 26 at 240 volts, 1 phase;
30/17.3 at 120/208 volts, 3 phase 3 wire; and 30 at 120
volts, 3 phase, 4 wire
Kilowatts 5
Kilovolt amperes 6.25
Hertz 400
Power factor 0.8
Phases 1 and 3
RPM 3,428 (approximately)

5. Wiring Diagram. Refer to figure 1-6.

NOTE:
BATTERY FURNISHED WITH APPLICABLE
END ITEM.

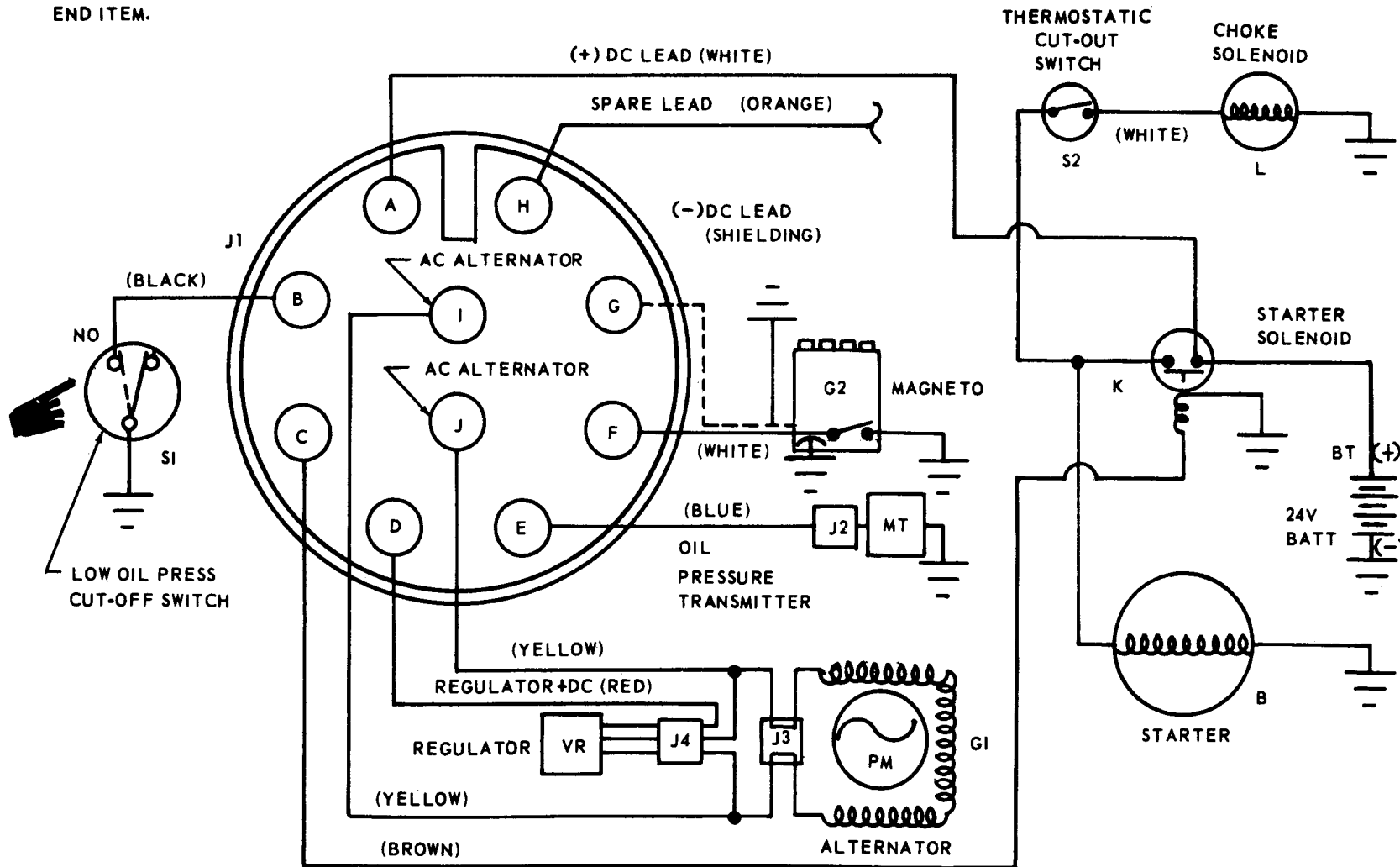

Figure 1-6. Wiring diagram (MEP-017A).

CHANGE 6 1-11

TM 5-6115-332-14
P-8-614-14
TO 35C2-3-424-1

TM 5-6115-332-14
P-8-614-14
TO 35C2-3-424-1

"A" PANEL WIRING DIAGRAM

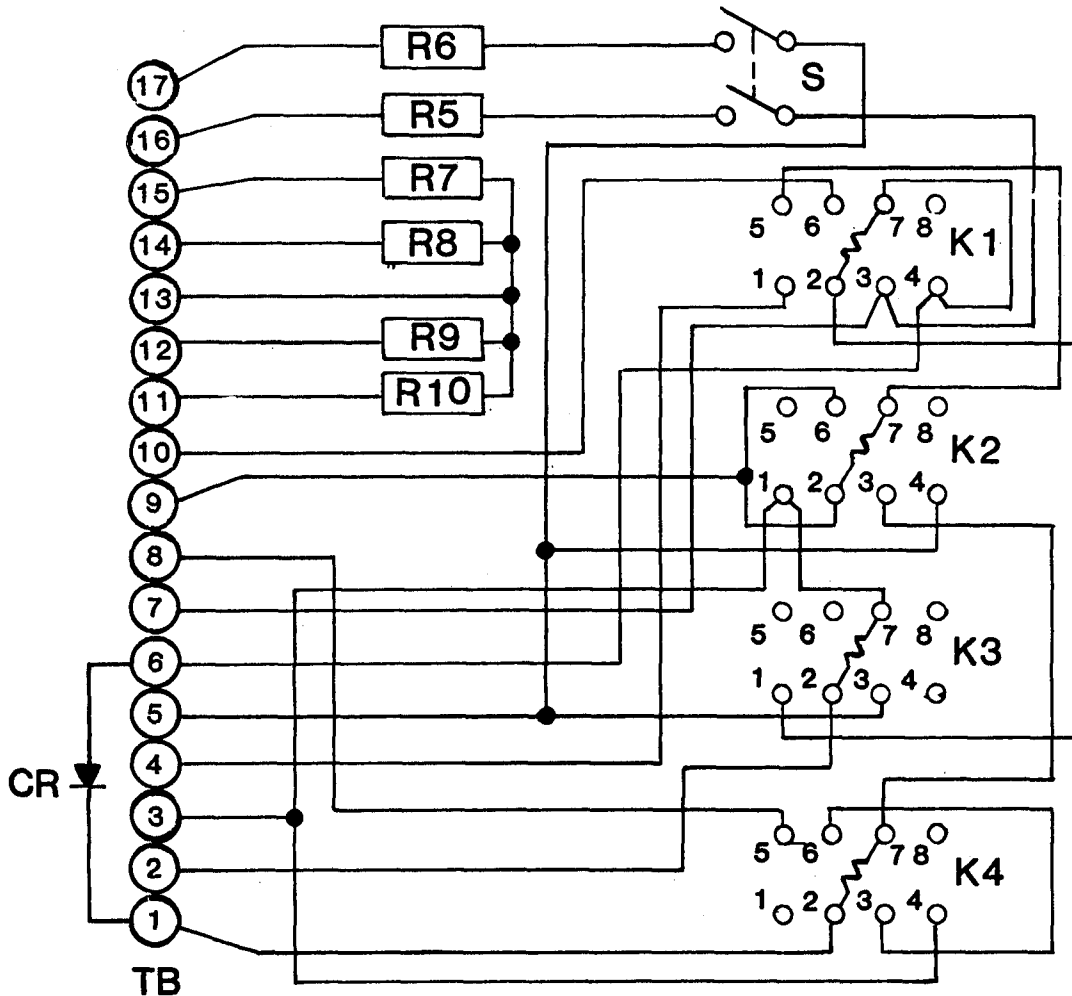

NOTE: SWITCH "S" (FIELD FLASH SWITCH) is connected to the battery through TERMINALS ⑤ & ⑦ and allows field flashing with unit shut down or operating.

| | | | |
|----|---------------------|--------|----------------|
| S | FIELD FLASH SWITCH | R5,6,7 | RESISTOR |
| CR | DIODE | 8,9,10 | |
| K1 | ENGINE RUN RELAY | TB | TERMINAL BOARD |
| K2 | START BY PASS RELAY | | |
| K3 | SHUT DOWN RELAY | | |
| K4 | START RELAY | | |

FIGURE 1-7 PANEL "A" WIRING DIAGRAM (MEP-017A)

Table 1-2. Direct Support and General Support Tabulated Data

1. Generator Classification and Rating. (Model MEP-017A and Model MEP-022A).

| | |
|--------------------------------------|--|
| Rating, voltage | 120/240 1 phase 120/280 3 phase |
| Amperage | 52 at 120 volts, 1 phase 26 at 240 volts, 1-phase 30/17.3 at 120/208 volts, 3 phase |
| Rating, kva (kilovolt amperes) | 6.25 |
| Rating, kw (kilowatts) | 5 |
| Hertz = cycles per second: | Model MEP-017A -60 Model-022A -400 Model MEP-022A -400 |
| Phase | 1 and 3 |
| Power factor | 0.8 |
| Drive | Direct |
| Cooling | Fan |

2. Torque Data.

| | |
|--|------------------------------------|
| Generator rotor drive disk mounting bolts | 90 to 110 in.- lb 16074-19646 cm |
| Exciter rotor mounting bolts | 90 to 110 in.- lb 16074-19646 cm |
| Exciter diode rectifiers | 12 to 15 in.- lb 2143.2-2679 cm |
| Exciter pole mounting bolts | 30 to 34 in.-lb 5358-6072.4 cm |
| Generator housing-to-flywheel housing adapter mounting bolts (Model MEP-022A) | 18 to 22 ft.-lb 2.5-3.0 kgm |
| Rotor-to-fan hub adapter mounting bolts | 18 to 22 ft.-lb. 2.5-3.0 kgm |
| Rotor drive disk-to-fan hub adapter mounting bolts | 18 to 22 ft.-lb 2.5-3.0 kgm |
| Generator housing mounting bolts | 18 to 22 ft.-lb 2.5-3.0 kgm |
| Fan mounting bolt | 14 to 16 ft.-lb 1.9-2.2 kgm |

1-11. Differences Between Models

This manual covers the DOD Model MEP-017A and DOD Model MEP-022A generator sets. Where differences exist, each model is covered separately in the applicable portions of this manual.

CHAPTER 2

Section I. OPERATING PROCEDURES

2-1. Controls and Instruments

a. General. This section describes the various controls and instruments and provides the operator with sufficient information to ensure proper operation of the generator set. All controls and instruments are identical on both the Model MEP-017A and the Model MEP-022A generator sets, with the single exception of the frequency meters. Although both of these are similar in the external appearance and are mounted in the same location, they are calibrated differently. The two frequency meters are covered separately within the controls and instruments paragraph.

b. Controls and Instruments. The generator controls and instruments and their normal reading are illustrated in figures 2-1, 2-2, 2-3, 2-4, 2-5 and 2-6. Refer to table 2-1 for the model applicability and use of the various controls and instruments required for proper operation of the generator set.

(1) Fuel Selector Valve. The fuel selector valve (fig. 2-1) is a four-position rotary-type valve located at the right side immediately behind the engine.

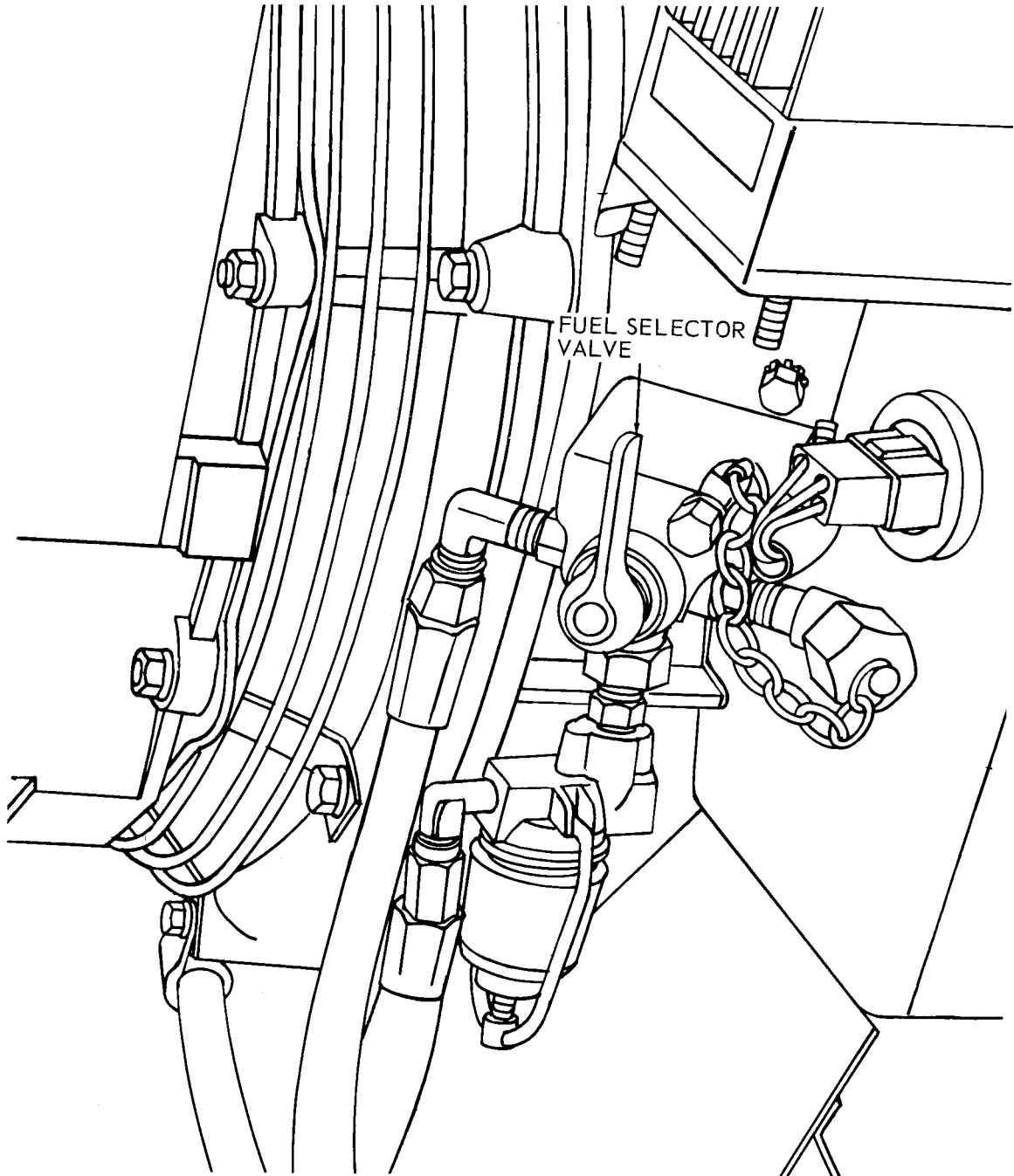

TS 6115-332-14/2-1

Figure 2-1. Fuel selector valve.

(2) Choke Control. The choke control (fig. 2-2) is a pull-type control located at the top center of the engine next to the engine governor.

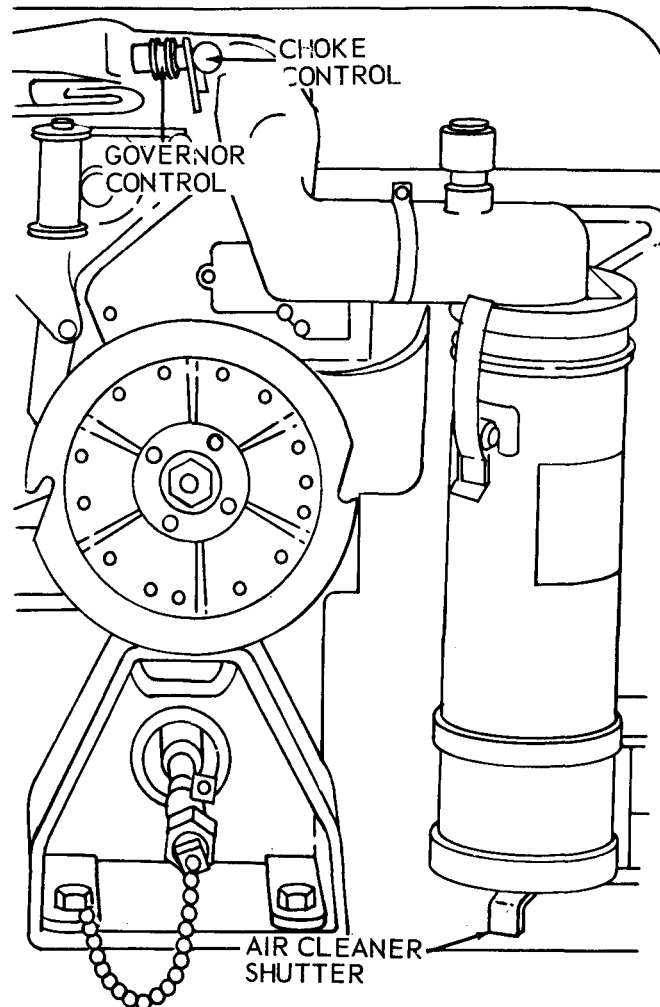

TS 5 6115-332-14/2-2

Figure 2-2. Choke control, governor control, and air cleaner intake shutter.

(3) Governor Control. The governor control (fig. 2-2) is a sliding, friction-lock type control located at the top center of the engine next to the engine governor.

(4) Air Cleaner Intake Shutter. The air intake shutter (fig. 2-2) is a sliding-type control, located in the bottom front of the air cleaner.

(5) **Oil Pan Baffle Rod (fig. 2-7).** The oil pan baffle rod is a rotating-type control located at the lower right side near the rear of the engine. It should be positioned toward the rear of the engine when ambient temperature is 0°F (-17.8°C) or

above. It should be positioned toward the front of the engine when the ambient temperature is below 0°F (17.8°C). (Refer to figure 2-7).

(6) **Panel Lights Switch.** A two-position toggle switch (fig. 2-3) located at the top center of the control panel.

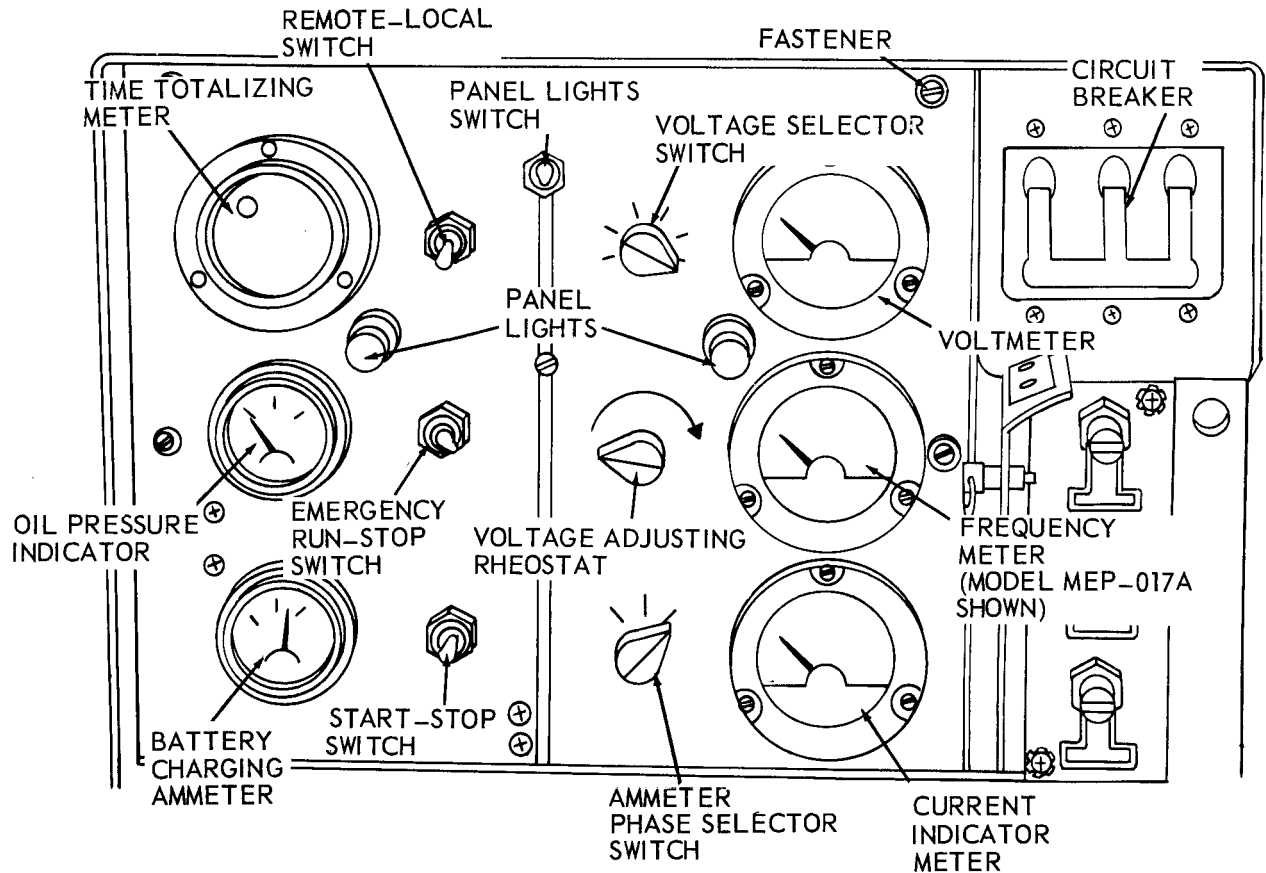

TS 6115-332-14/2-3

Figure 2-3. Generator control panel, controls, instruments, and panel lights.

(7) Remote-Local Switch. The remote-local switch (fig. 2-3) is a two-position toggle switch located slightly left of center in the upper part of the control panel.

(8) Emergency Run-Stop Switch. The emergency stop-run switch (fig. 2-3) is a three-position toggle switch, located at the left center of the control panel.

(9) Start-Stop Switch. The start-stop switch (fig. 2-3) is a three-position, momentary-type toggle switch that is located left of center at the bottom of the control panel.

(10) Oil Pressure Indicator. The oil pressure indicator (fig. 2-3) is calibrated from 0 to 60 psi and is located at the left center of the control panel. The normal readings range from 20 psi at approximately

1/4 rated speed to a maximum of 60 psi at rated governed speed.

(11) Time Totalizing Meter. The time totalizing meter (fig. 2-3) is located at the upper left corner of the control panel.

(12) Battery Charging Ammeter. The battery charging ammeter (fig. 2-3) is located at the lower left corner of the control panel. The instrument is calibrated from 0 to +15 and 0 to -15 amperes. When the battery is fully charged and the unit is operating, the ammeter needle should normally rest at a position slightly on the + side of 0.

(13) Output Selector Switch. The output selector switch (fig. 2-4) is a four-position rotary-type switch located inside the control box near the central right side of the control box.

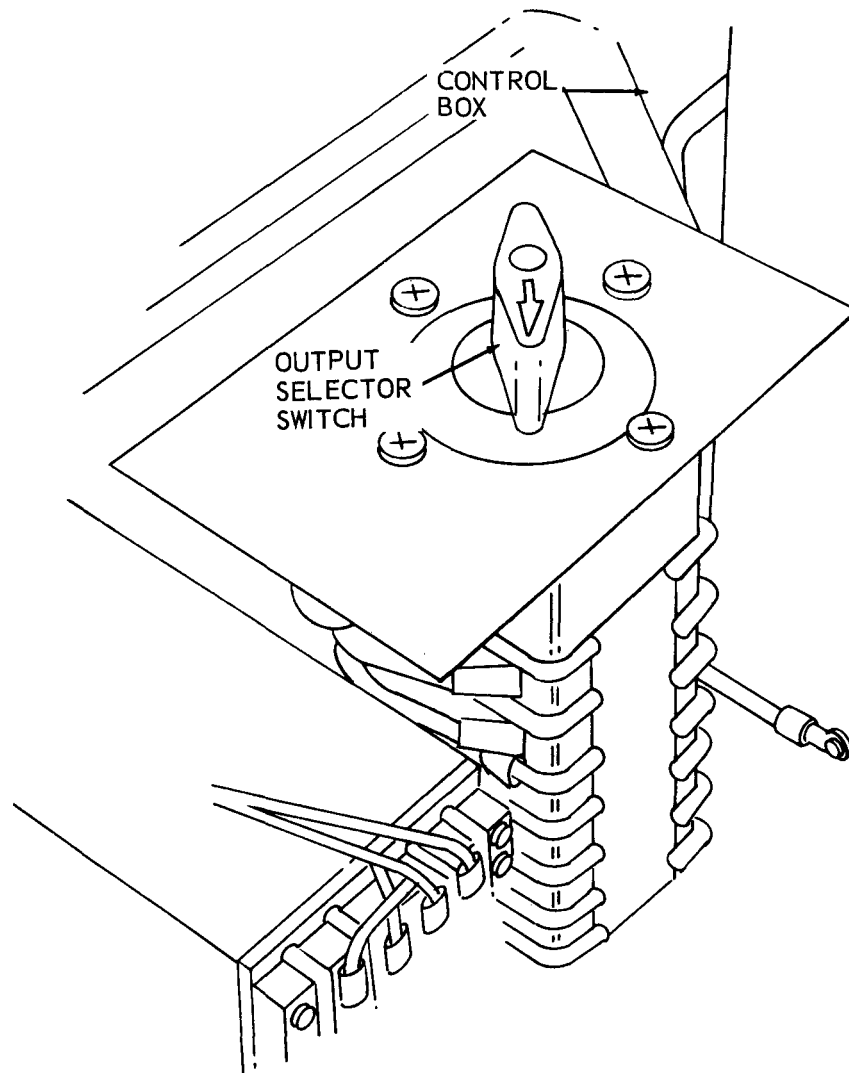

TS 5-6115-332-14/2-4

Figure 2-4. Output selector switch.

(14) Field Flash Switch. The field flash switch (fig. 2-5) a two position momentary-type toggle switch and is located inside the control box near the control left side.

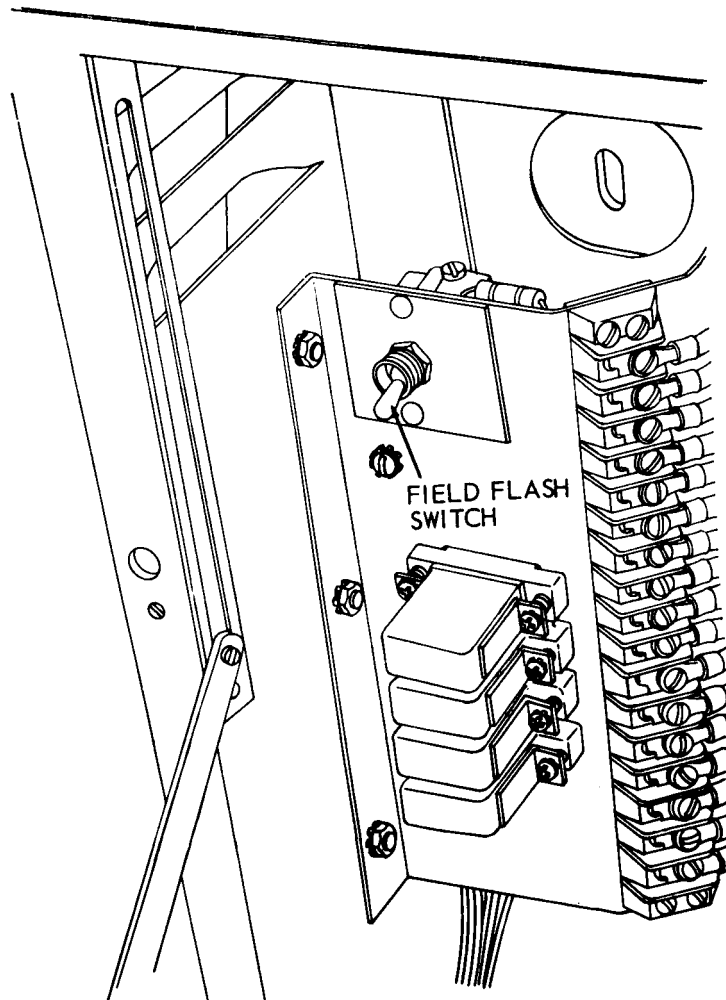

TS 6115-332-14/2-5

Figure 2-5. Generator field flash switch.

(15) Voltage Selector Switch. The voltage selector switch (fig. 2-3) a six-position, rotary-type, switch is located slightly to the right of center in the upper part of the control panel. The voltages indicated should be as shown in Table 2-2 for the appropriate position of the output selector switch.

(16) Voltmeter. The voltmeter (fig. 2-3) is located in the upper right corner of the control panel. The voltmeter is calibrated for 0 to 250 volts and is redlined at 240 volts, a value that should not be exceeded.

(17) Voltage Adjusting Rheostat. The voltage adjusting rheostat (fig. 2-3) is located just to the right of the center of the control panel. To increase the voltage turn the control clockwise to decrease the voltage turn the control counter-clockwise.

(18) Circuit Breaker. The circuit breaker (fig. 2-3) is located to the right of the upper part of the control panel. It is a two position, toggle-type control.

(19) Ammeter Phase Selector Switch. The ammeter phase selector switch (fig. 2-3), a three-position rotary-type switch, is located to the right of center in the lower part of the control panel.

(20) Current Indicator Meter. The current

indicator meter (fig. 2-3) is located in the lower right corner of the control panel. It is calibrated from 0 to 125 percent. The scale is redlined in that scale area above 100 percent. The scale is also marked with a line at the 80 percent position that is marked 100 percent at 1.0 power factor (unity).

(21) Frequency Meter (Model MEP-017A). The frequency meter (fig. 2-3) is located at the right center of the control panel. The scale of the meter is graduated from 55 to 65 cycles per second (Hertz).

(22) Frequency Meter (Model MEP-022A). The frequency meter (fig. 2-6) is located at the right center of the control panel. The scale of the meter is graduated from 380 to 420 cycles per second (Hertz).

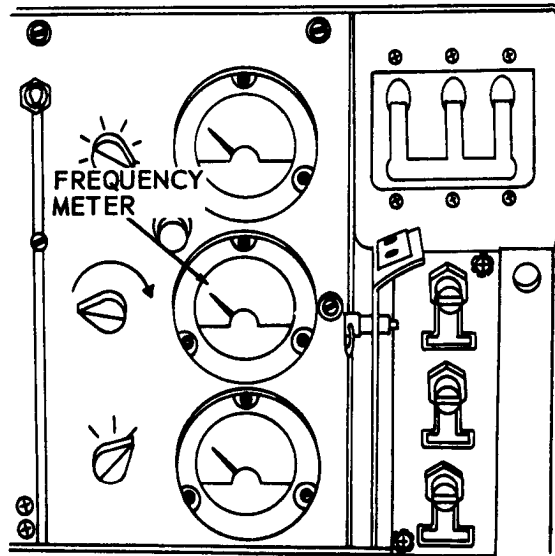

TS 6115-332-14/2-6

Figure 2-6. Generator frequency meter, (Model MEP-022A).

Table 2-1. Controls and Instruments

| NOMENCLATURE | DOD MODEL | USE |
|----------------------------|-----------|---|
| Fuel Selector Valve | All | To turn fuel supply off, or to select between an external fuel supply and the fuel can located on unit. |
| Choke Control | All | To choke the engine during starts made when the engine is cold. |
| Governor Control | All | To control the governor for starting and operation. |
| Air Cleaner Intake Shutter | All | To provide preheated air to the carburetor when the ambient temperature falls below 25°F. (-3.9°C). |
| Oil Pan Baffle Rod | All | Controls the flow of cooling air to the oil pan. |
| Panel Lights Switch | All | Control operation of the panel lights. |
| Remote - Local Switch | All | To switch the unit into either the LOCAL or REMOTE mode of operation. |
| Emergency Run-Stop Switch | All | To put the engine safety controls in or out of circuit and also to provide for stopping the unit when under emergency conditions. |
| Start-Stop Switch | All | To stop or start the engine when the unit is in the local mode of operation. |
| Oil Pressure Indicator | All | Indicates the engine oil pressure. |
| Time Totalizing Meter | All | Indicates the total engine running time in hours and tenths of an hour. |

**Table 2-1. Controls and Instruments
(Cont'd)**

| NOMENCLATURE | DOD MODEL | USE |
|-------------------------------|-----------|---|
| Battery Charging Ammeter | All | Indicates the battery charging rate. |
| Output Selector Switch | All | To reconnect the generator phase windings to provide the different output characteristics. |
| Field Flash Switch | All | To flash the generator field momentarily with battery current. |
| Voltage Selector Switch | All | To select the phase winding on which a voltage reading is wanted. |
| Voltmeter | All | Indicates the voltage of the generator phase that has been selected using the voltage selector switch. |
| Voltage Adjusting Rheostat | All | To increase or decrease the voltage. |
| Circuit Breaker | All | To connect and disconnect the load. |
| Ammeter Phase Selector Switch | All | To select the phase of the generator on which a current reading is wanted. The indication will be shown on the current indicator meter. |
| Current Indicator Meter | All | Indicates the current in the generator phase that has been selected using the ammeter phase selector switch. |
| Frequency Meter | MEP-017A | Indicates the frequency of the generated power. |
| Frequency Meter | MEP-022A | Indicates the frequency of the generated power, |

Table 2-2. Voltmeter Indications

NOTE

The voltages listed in the VOLTMETER INDICATION column are intended to be read only from the generator set voltmeter. Any voltage reading below the 50 volt mark (in the suppressed portion of the meter) is listed in Table 2-2 as Zero. Using any voltage indication except Zero below the 50 volt mark will result in false readings.

| <u>OUTPUT SELECTOR SWITCH</u> | <u>VOLTAGE SELECTOR SWITCH</u> | <u>VOLTMETER INDICATION</u> |
|--|------------------------------------|---------------------------------|
| 240 Volt 1 Phase 2 Wire L2 L3 | V0-1 | Zero |
| | V0-2 | 60-70 |
| | V0-3 | 60-70 |
| | V1-3 | 60-70 |
| | V1-2 | 60-70 |
| | V2-3 | 240 |
| 120 Volt 1 Phase 2 Wire L2 L3 | V0-1 | Zero |
| | V0-2 | Zero |
| | V0-3 | Zero |
| | V1-3 | Zero |
| | V1-2 | Zero |
| | V2-3 | 117 |
| 120 Volt 3 Phase 3 Wire L1 L2 L3 | V0-1 | 60-70 |
| | V0-2 | 60-70 |
| | V0-3 | 60-70 |
| | V1-3 | 117 |
| | V1-2 | 117 |
| | V2-3 | 117 |
| 102/208 Volt 3 Phase 4 Wire L0 L1 L2 L3 | V0-1 | 117 |
| | V0-2 | 117 |
| | V0-3 | 117 |
| | V1-3 | 208 |
| | V1-2 | 208 |
| | V2-3 | 208 |

2-2. Operations Under Usual Conditions

a. General.

CAUTION

Do not operate at idle speed. At idle speed, frequency drops below 60Hz, exciter field voltage increases, thereby causing voltage regulator to operate at maximum output. This causes overloading of power transistor.

(1) The instructions in this paragraph are for the information and guidance of the personnel that are responsible for the operation of the generator set.

(2) The operator must know how to perform every operation of which the generator set is capable. This section contains instructions on starting and stopping the generator set, on operation of the generator set, and on co-ordinating the basic motions to perform the specific tasks for which the equipment is designed.

b. Starting.

(1) Preparation for Starting.

(a) Perform the daily preventive maintenance services (para. 3-6).

(b) If an auxiliary fuel source is to be used, connect the auxiliary fuel line.

(c) The generator set must be grounded prior to operation. The ground can be in order of preference an underground metallic water pipe system, a driven metal rod or a buried metal plate. A ground rod must have a minimum diameter of 5/8 inch if solid or 3/4 inch if pipe; and must be driven to a minimum depth of 8 feet. A ground plate must have a minimum area of 9 square feet and be buried at a minimum depth of 4 feet. The ground lead must be copper wire, minimum size no. 6 AWG (American Wire Gage), which should be bolted or clamped to the rod, plate, or piping system and to the generator ground terminal stud (fig. 1-1 or 1-3).

WARNING

Do not operate the generator set until the ground stud terminal has been connected to suitable ground. Electrical faults in the generator set, load lines, or load equipment can cause death by electrocution from contact with an ungrounded system.

(d) Select the proper voltage output to meet load requirements and connect the proper load cables.

(e) Position circuit breaker in OFF position.

(2). **Electric Starting (Local).** Refer to figure 2-7 for local mode electric starting instructions.

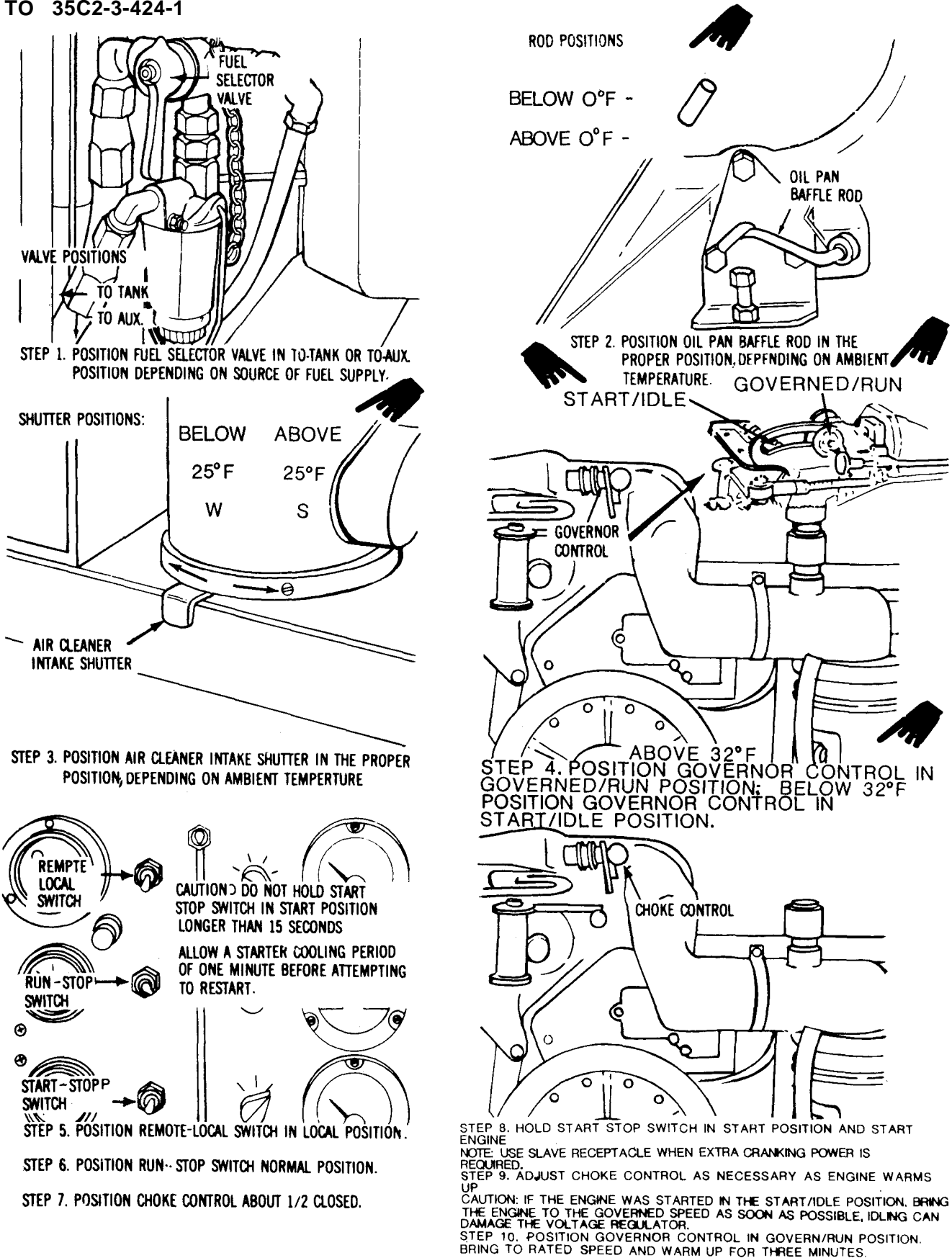

Figure 2-7. Electric starting instructions, local made.

(3) Manual Starting.

WARNING

Serious eye injury can result from the starter rope knot. Wear eye protection when pull starting engine.

Refer to figure 2-8 for manual starting instructions.

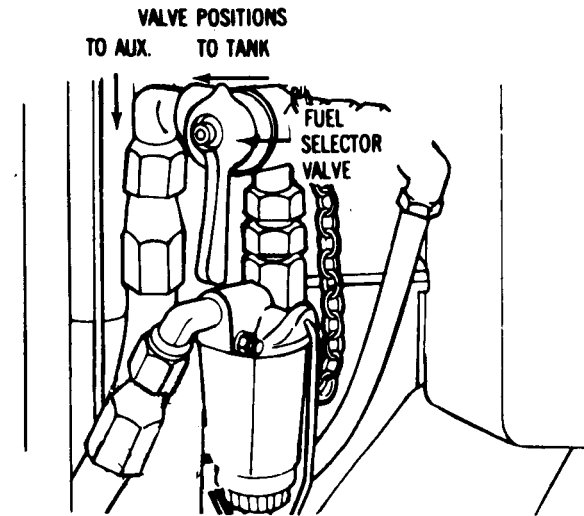

STEP 1. POSITION FUEL SELECTOR VALVE IN TO TANK OR TO-AUX. POSITION DEPENDING ON SOURCE OF FUEL SUPPLY.

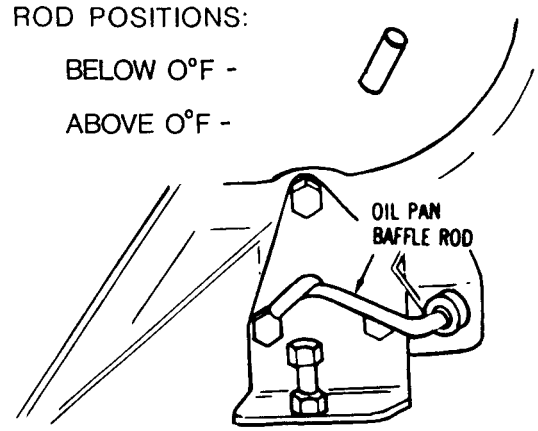

STEP 2. POSITION OIL PAN BAFFLE ROD IN THE PROPER POSITION DEPENDING ON AMBIENT TEMPERATURE.

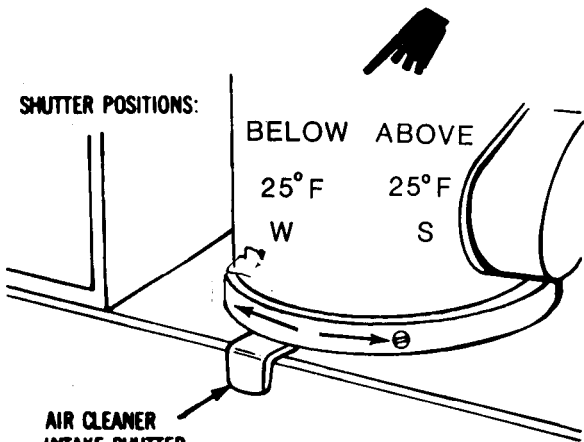

STEP 3. POSITION AIR CLEANER INTAKE SHUTTER IN THE PROPER POSITION, DEPENDING ON AMBIENT TEMPERATURE.

NOTE: WHEN OPERATING IN THE EMERGENCY RUN POSITION, THE LOW OIL PRESSURE SAFETY SWITCH IS BYPASSED

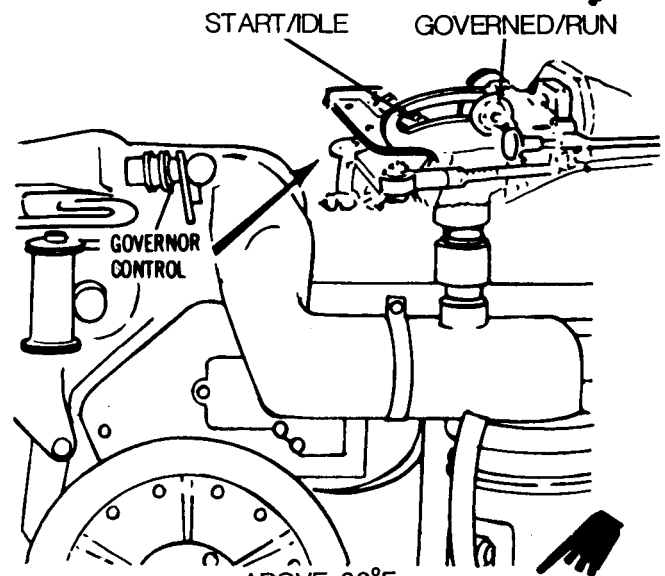

STEP 4. POSITION GOVERNOR CONTROL IN GOVERNED/RUN POSITION; BELOW 32°F POSITION GOVERNOR CONTROL TO START/IDLE POSITION

Figure 2-8. Manual starting instructions.

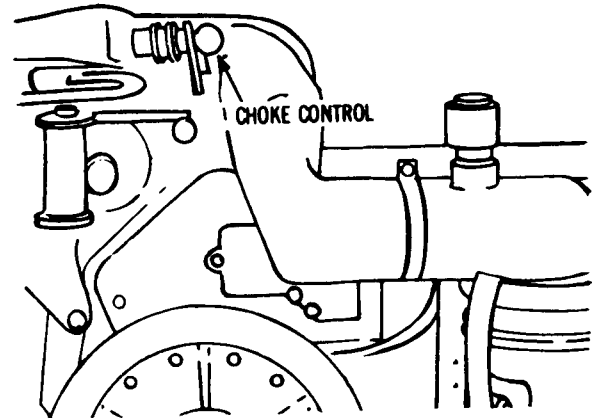
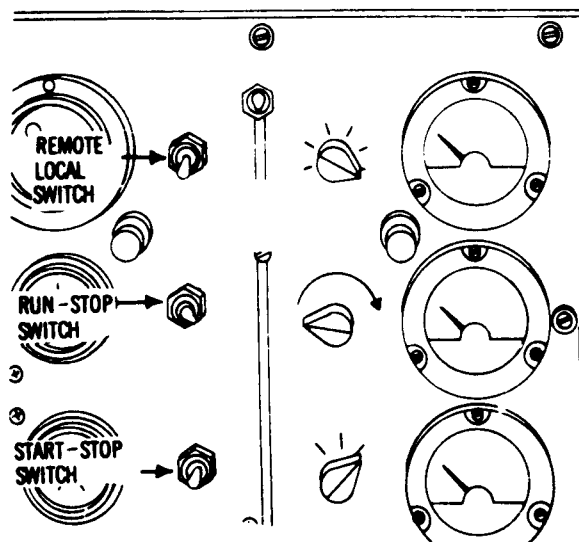

STEP 5. POSITION REMOTE-LOCAL SWITCH IN LOCAL POSITION.

STEP 6. POSITION EMERGENCY RUN-STOP SWITCH TO EMERGENCY RUN POSITION.

STEP 7. POSITION CHOKE CONTROL ABOUT $\frac{3}{4}$ CLOSED.

WARNING

Serious eye injury can result from the starter rope knot. Wear eye protection when pull starting engine.

STEP 8. TAKE ONE QUICK STEADY PULL WITH THE STARTER ROPE. IF THE ENGINE DOES NOT START, CLOSE CHOKE ALL THE WAY. PULL STARTER ROPE UNTIL ENGINE STARTS.

STEP 9. WHEN ENGINE OIL PRESSURE REACHES OPERATING PRESSURE, PLACE EMERGENCY RUN-STOP SWITCH TO NORMAL POSITION. AT THE SAME TIME, MOMENTARILY PLACE THE START-STOP SWITCH TO THE START POSITION.

CAUTION

If the engine was started in the START/IDLE position, bring the engine to the governed speed as soon as possible. Idling can damage the voltage regulator.

STEP 10. ADJUST CHOKE CONTROL AS NECESSARY AS ENGINE WARMS UP.

STEP 11. POSITION GOVERNOR CONTROL IN GOVERN/RUN POSITION. BRING TO RATED SPEED AND WARM UP FOR THREE MINUTES.

Figure 2-8. Manual starting instructions.

(4) Remote Mode Starting. The remote control terminal board (fig. 2-9) is located on the right

rear of the control box. It provides the connection points required for starting and stopping the generator set from a remote position.

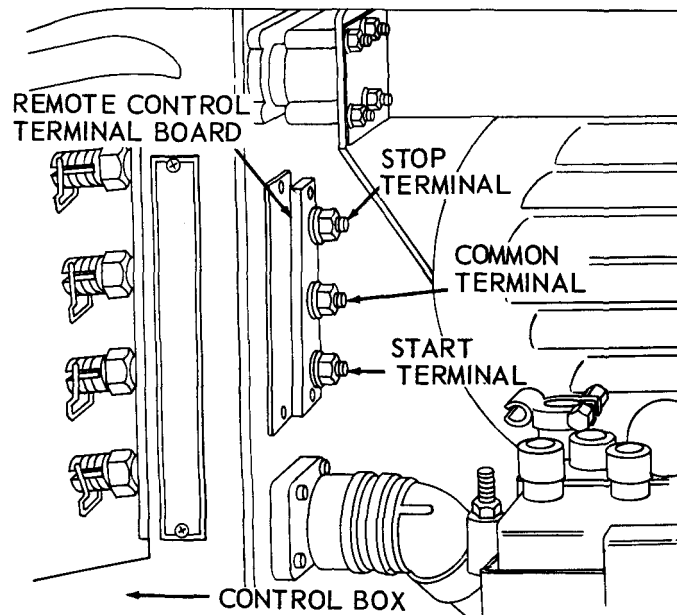

TS 6115-332-14/2-9

Figure 2-9. Remote control terminals.

(a) Position the REMOTE-LOCAL switch (fig. 2-7) in the REMOTE position.

(b) To start the generator set from a remote position, make contact between the start terminal and the common terminal of the remote control terminal board (fig. 2-9). As soon as the unit starts, break contact.

(5) Cold Weather Starting. When the ambient temperature is -25°F (-31.7°C) and below it will be necessary to preheat the engine using a blowtorch (see para. 2-4). After preheating the engine, proceed with electrical or manual starting as outlined in (2) and (3), above.

c. Stopping.

(1) Local Mode Stopping. Refer to figure 2-10 for local mode stopping instructions.

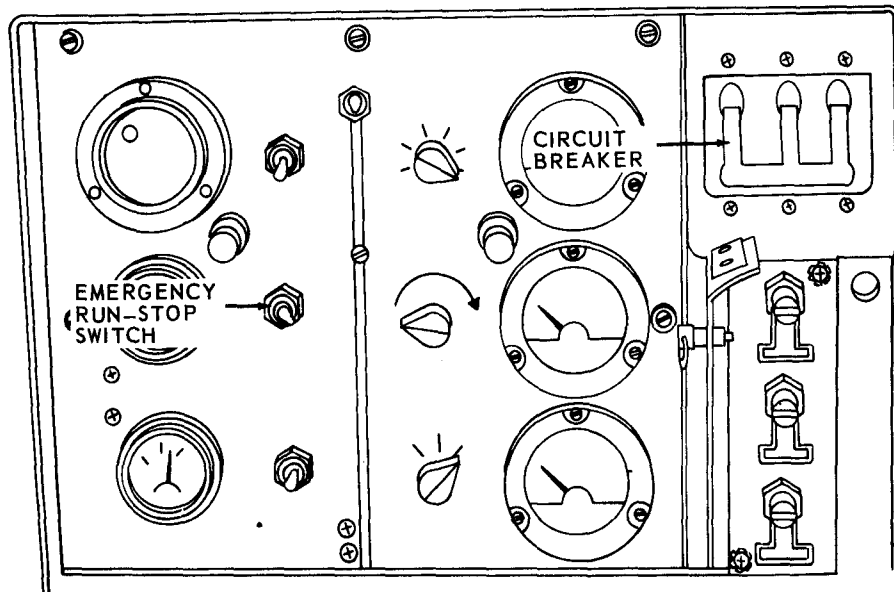

STEP 1. POSITION CIRCUIT BREAKER IN OFF POSITION.

STEP 2. TURN VOLTAGE ADJUST RHEOSTAT COUNTER-CLOCKWISE ALL THE WAY.

NOTE: FOR EMERGENCY STOP, POSITION RUN-STOP SWITCH IN EMER. STOP POSITION.

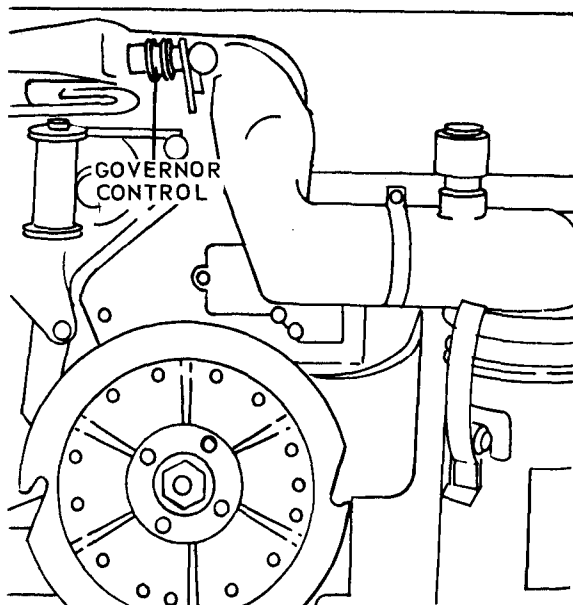

STEP 3. MAINTAIN GOVERNOR CONTROL IN GOVERN/RUN POSITION AND ALLOW ENGINE TO COOL DOWN FOR THREE MINUTES.

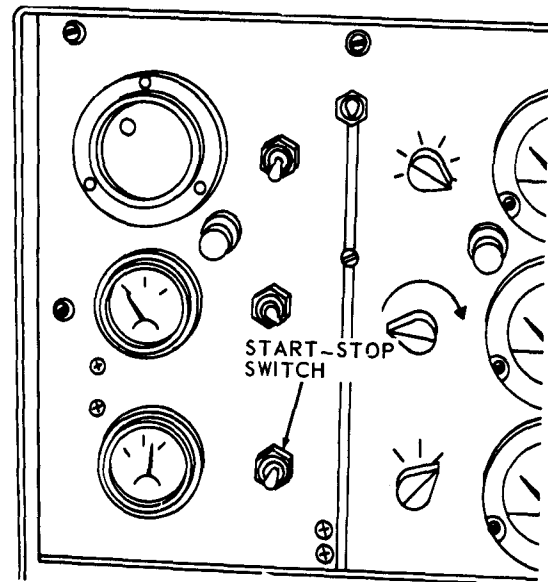

STEP 4. POSITION START-STOP SWITCH IN STOP POSITION.

NOTE: IF ENGINE HAS TENDENCY TO DIESEL (CONTINUE RUNNING) AFTER SHUTDOWN, FUTURE SHUTDOWNS SHOULD BE PERFORMED BY PLACING THE GOVERNOR CONTROL IN THE START/IDLE POSITION AFTER COOL DOWN AND JUST PRIOR TO SHUTDOWN.

TS 6115-332-14/2-10

Figure 2-10. Stopping instructions, local mode.

(2) Remote Mode Stopping. To stop the generator set from a remote position, make contact between the stop terminal and common terminal of the remote control terminal board (fig. 2-9). As soon as the unit stops, break contact.

d. Operation of Equipment.

(1) General. When the unit is operating and is connected to a load the generator normally operates at the selected voltage, a value that will be indicated by the voltmeter. The operator must be observant of the generator set, pay particular attention to any unusual sounds that may indicate malfunction. In case of such an event, stop the unit and report the condition to organizational maintenance.

(2) Operation.

(a) Start the engine (para. 2-2b).

(b) Adjust the governor to achieve a reading of 60 Hz on the model MEP-017A unit or a reading of 400 Hz on the model MEP-022A unit (fig. 2-12).

(c) Observe the voltmeter (fig. 2-3). Turn the knob of the voltage adjusting rheostat (fig. 2-3), if necessary, until the proper voltage is attained, as indicated by the voltmeter.

NOTE

If voltage does not build up, exercising care not to touch electrical contacts, momentarily depress the field flash switch (fig. 2-5).

(d) Position the circuit breaker (fig. 2-3) in the ON position.

(e) Again, observe the voltmeter and adjust the voltage adjusting rheostat to attain the proper voltage, if necessary.

(f) Position the ammeter phase selector switch (fig. 2-3) in each of the three positions in turn, and at the same time observe the current indicator meter (fig. 2-3). The meter should not give an indication greater than 100% in any phase with any type load. With a straight, resistive load, such as incandescent lighting, it should not exceed 80% (100% at 1.0 power factor). If the meter indicates a load greater than these values in any phase, reduce the load. Balance the load on each of the three phases, if possible.

(g) Position the voltage selector switch (fig. 2-3) in each of the six positions, in turn, and obtain a voltmeter reading in each of the six positions.

NOTE

If the voltage drops under load, the voltage regulator is defective. Report the condition to organizational maintenance.

Section II. OPERATION OF AUXILIARY EQUIPMENT

2-3. General

A blowtorch that is specifically designed for preheating the engine is available for issue. It is normally to be used at temperatures below -25°F (-31.7°C). Refer to paragraph 2-4 for the operating instructions and special precautions that apply to the use of the blowtorch.

2-4. Blowtorch

a. Description. The blowtorch is a multifuel pump-type torch. It has a fuel capacity of one pint. It is used to preheat the engine crankcase, cylinder heads, intake manifold, and aid intake preheater.

CAUTION

When using a torch for preheating, play the flame back and forth. Do not

hold the flame in any one spot. Keep heat and flame away from non-metallic parts. When cranking with the starter, do not crank longer than 8 seconds. Allow 2 minutes for the starter to cool, between cranking periods.

b. Operation and Service. For blowtorch operation and service instructions, refer to figure 2-11.

NOTE

Play the flame back and forth over the cylinder heads and intake manifold, briefly, then play the flame over the air intake preheater for 1 or 2 minutes. While still applying heat, crank the engine. If the engine fails to start after several tries, apply heat to the drive end of the magnets briefly and then to the exposed surfaces of the oil pan for about 5 minutes. Extended cranking with the choke "closed" will cause flooding of the engine. If this happens, remove, dry and reinstall the spark plugs.

NOTE: WHEN TYPE OF FUEL IS CHANGED COIL CONTROL SCREW MUST BE REPOSITIONED. LOOSEN WINGNUT PLACE SCREW AT TOP FOR JP-4 FUEL, IN CENTER FOR REGULAR GASOLINE, AND AT BOTTOM FOR ARCTIC GASOLINE.

WARNING: DO NOT STAND IN FRONT OF TORCH WHILE IT IS BEING IGNITED.

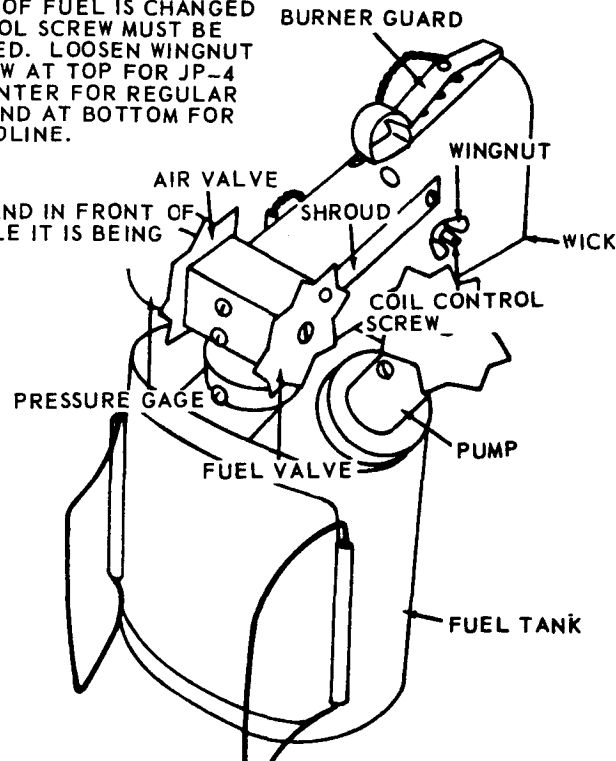

1. TURN PUMP COUNTERCLOCKWISE AND REMOVE FROM FUEL TANK.
 2. FILL FUEL TANK TWO-THIRDS FULL WITH FUEL.
 3. INSTALL PUMP AND TIGHTEN SECURELY.
 4. CLOSE AIR VALVE AND FUEL VALVE.
 5. OPERATE PUMP UNTIL PRESSURE GAGE READS 50 PSI (POUNDS PER SQUARE INCH). (3.515 KG PER SQ. CM)
 6. OPEN FUEL VALVE MOMENTARILY TO SATURATE WICK. CLOSE FUEL VALVE.
 7. REMOVE BURNER GUARD FROM SHROUD.
 8. IGNITE WICK.
 9. OPEN FUEL VALVE: THEN OPEN AIR VALVE.
 10. SLOWLY CLOSE AIR VALVE AS TORCH FLAME BEGINS TO TURN BLUE.
- NOTE: AIR VALVE MUST BE CLOSED EXCEPT WHEN IGNITING AND EXTINGUISHING TORCH.
11. LOOSEN WINGNUT, MOVE CONTROL SCREW UP OR DOWN UNTIL FLAME BURNS BLUE WITH YELLOW TIP, AND TIGHTEN WINGNUT.
- NOTE: FLAME MUST HAVE SOME YELLOW TIP TO KEEP AIR-FUEL MIXTURE AT PROPER TEMPERATURE.
12. HEAT OUTPUT OF TORCH IS CONTROLLED BY FUEL TANK PRESSURES LISTED BELOW.
REPUMP AS REQUIRED:
 - 55 PSI - 50,000 BTU/HR (BRITISH THERMAL UNITS PER HOUR) (3.8665 KG PER SQ. CM)
 - 40 PSI - 25,000 BTU/HR (2.812 KG PER SQ. CM)
 - 20 PSI - 15,000 BTU/HR (1.406 KG PER SQ. CM)
 13. TO EXTINGUISH TORCH: CLOSE FUEL VALVE AND OPEN AIR VALVE.
 14. INSTALL BURNER GUARD ON SHROUD.

TS 6115-332-14/2-11

Figure 2-11. Blowtorch operation and service instructions.

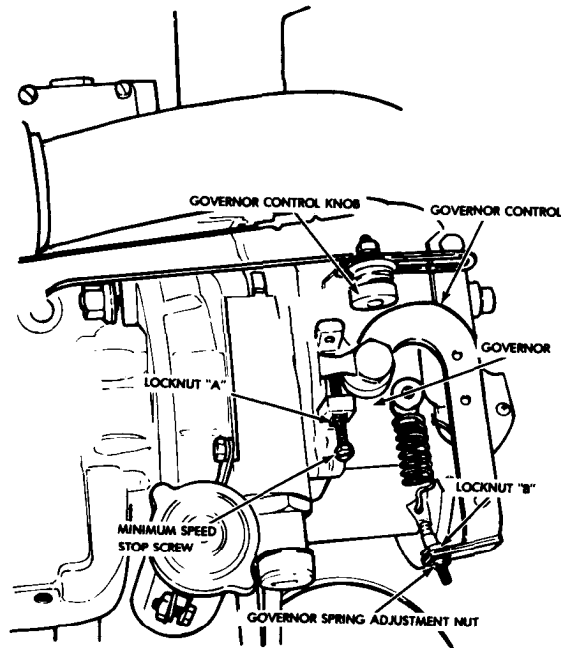

STEP 1. START ENGINE.

STEP 2. LOOSEN GOVERNOR CONTROL KNOB AND PLACE GOVERNOR CONTROL IN GOVERN OR RUN POSITION. TIGHTEN KNOB. ALLOW ENGINE TO WARM UP FOR THREE MINUTES.

STEP 3. TURN CIRCUIT BREAKER TO ON POSITION (FIG. 2-3) TO APPLY LOAD.

NOTE: CHECK FREQUENCY METER FOR ENGINE SPEED/FREQUENCY READINGS. FREQUENCY METER IS DIRECTLY PROPORTIONAL TO ENGINE SPEED.

STEP 4. LOOSEN LOCKNUT A AND TURN MINIMUM SPEED STOP SCREW TO GET ENGINE SPEED/FREQUENCY SHOWN IN TABLE 2-3. TIGHTEN LOCKNUT A.

STEP 5. TURN CIRCUIT BREAKER TO OFF POSITION TO REMOVE LOAD.

STEP 6. LOOSEN LOCKNUT B AND TURN GOVERNOR SPRING ADJUSTMENT NUT CLOCKWISE UNTIL ENGINE BEGINS TO SURGE OR "HUNT".

STEP 7. TURN GOVERNOR SPRING ADJUSTMENT NUT COUNTER-CLOCKWISE UNTIL ENGINE STOPS SURGING OR "HUNTING". TIGHTEN NUT.

STEP 8. TURN CIRCUIT BREAKER TO ON POSITION TO APPLY LOAD AND CHECK ENGINE SPEED/FREQUENCY.

NOTE: IF ENGINE SPEED/FREQUENCY DOES NOT MATCH FIGURE SHOWN IN TABLE 2-3, REPEAT STEPS 3 THROUGH 8.

Figure 2-12. Governor Adjustment Procedures

Table 2-3. Engine Speed/Frequency

| Model | RPM | Frequency |
|----------|------|-----------|
| MEP-017A | 3600 | 60HZ |
| MEP-022A | 3428 | 400 HZ |

Section III. OPERATION UNDER UNUSUAL CONDITIONS

2-5. Operation in Extreme Cold (Below 0°F) (-17.8°C)

a. General. The generator sets are designed to operate at temperatures as low as -65°F (-53.8°C). To operate the unit at temperatures below 0°F, position the air cleaner intake shutter (fig. 2-7) in the WINTER position and move the oil pan baffle rod (fig. 2-7) to the position toward the front of the engine.

b. Engine Preheating. When the ambient temperature is -25°F (-31.7°C) and below, preheat the engine. For instructions on preheating the engine using a blowtorch, refer to paragraph 2-4.

c. Lubrication. The generator does not require lubrication. For engine lubrication instructions refer to LO 5-2805-258-12 and TM 5-2805-258-14. Additionally, lubricate the ball joints at each end of the throttle control rod with a light oil suitable for use at 0°F to -65°F; order NSN 9150-00-257-5449, MIL-L-10295.

d. Battery. Keep the battery fully charged. After adding water to the battery, charge the battery by external means or by running the engine for a period of at least one hour.

e. Fuel System. When not in operation, keep fuel supply cans or other containers full to prevent condensation of moisture. Be careful to prevent ice, snow, and moisture from entering the fuel system. Accumulated moisture will freeze and clog the system. Inspect the fuel filter for accumulated moisture after each operating period and if any is found, service the fuel filter. Refer to TM 5-2805-258-14 for service instructions.

CAUTION

Disturb wiring as little as possible during cold weather. Insulation on wiring becomes brittle when cold and will break easily.

f. Electrical Systems. Keep wiring and electrical components free of ice, snow, and moisture.

g. Operation. Allow the engine to warm thoroughly before applying load.

h. Protection. Provide as much protection for the equipment as is practical, at all times. When the equipment is not in use, cover it with canvas or other protective covering.

2-6. Operation in Extreme Heat

a. General. When operating the equipment at a time when ambient temperatures are high, efficient cooling and adequate lubrication are vitally important.

b. Cooling. Provide maximum ventilation at all times. Keep the equipment clean, paying particular attention to the engine shrouds and cooling fins and the generator blower cover. See that all air passages are free of obstructions. Make certain the air cleaner shutter (fig. 2-7) is in the SUMMER position and that the oil pan baffle rod (fig. 2-7) has been moved to the position toward the rear of the engine.

c. Operation. Do not load the generator beyond its rated capacity. If possible, keep the generator load to a minimum. Make frequent meter readings to detect any overload. If an overload is indicated, reduce the load or stop the unit and take corrective action.

d. Battery. The water in the electrolyte evaporates during normal battery use. At high temperatures, the loss of water is accelerated. Inspect the electrolyte level more frequently and add water as required to maintain the water level above plates.

2-7. Operation in Dusty or Sandy Areas

a. General. When the unit is operated in dusty or sandy areas, take special precautions to keep the unit clean and adequately lubricated.

b. Fuel System. Use care to prevent dust and sand from entering the fuel system. Inspect the fuel filter after each operating period. Refer to TM 5-2805-258-14 for filter service instructions.

c. Lubrication. For engine lubrication instructions refer to LO 5-2805-258-12 and TM 5-2805-258-14. (F) Air force personnel refer to the lubrication section of application TO 35C2-3-1-426 WC-Series Workcards.

d. Air Cleaner. When the equipment is being operated, observe the air cleaner restriction indicator frequently. Service the air cleaner when the indicator shows red. Refer to TM 5-2805-258-14 for air cleaner service instructions.

e. Protection. At all times, provide as much protection for the equipment as is practical. Take advantage, if possible, of natural barriers or erect an improvised barrier. When it is not in use, cover the unit with canvas or other protective covering.

2-8. Operation Under Rainy or Humid Conditions

a. Fuel System. Use care to prevent moisture from entering the fuel system. Inspect the fuel filter for accumulated moisture after each period of operation. Refer to TM 5-2805-258-14 for filter service instructions.

b. Lubrication. (F) Air Force personnel refer to the lubrication section of applicable TO 35C2-3-1-426 WC-Series Workcards.

c. Electrical System. Keep electrical system components and wiring clean and dry, to prevent corrosion, deterioration, and short circuits.

d. Protection. At all times, provide as much protection for the equipment as is practical. When the unit is not in use, cover it with canvas or other protective covering. During dry periods, remove the cover long enough to allow all the equipment to dry thoroughly.

2-9. Operation in Salt Water Areas

a. General. Wash the equipment frequently with fresh water and follow the instructions in paragraph 2-8. Protect electrical components when washing.

b. Protection. Coat exposed metal parts with general purpose grease, MIL-G-10924

2-10. Operation at High Altitudes

The generator sets are rated 5KW at altitudes up to 5,000 feet (1525m) and are rated 4KW at an altitude of 8,000 feet (2438m). To calculate the usable output rating for an altitude above 8,000 feet (2438m) use the following formula:

$$\frac{6\% \times (\text{actual altitude} - 5,000) \times 5\text{KW}}{1,000} = \text{derating factor}$$

$$5\text{KW} - \text{derating factor} = \text{Usable output}$$

EXAMPLE: Solution for 10,000 ft (3048 m).

$$\frac{6\% \times (10,000 - 5,000) \times 5\text{KW}}{1,000} = \text{derating factor}$$

$$0.06 \times 5 \times 5\text{KW} = \text{derating factor} = 1.5\text{KW}$$

$$5\text{KW} - 1.5\text{KW} = 3.5\text{KW} \text{ (Usable output at 10,000 ft. (3048 m) altitude.)}$$

2-11. Operation Using NATO Slave Cable

The existing Army Slave Cable has end connectors with two pins to mate with the Slave Receptacle on the Generator Set (fig. 1-1). The NATO Slave Cable has end connectors with one pin. In order to utilize the NATO Slave Cable on the Generator Set, an Adapter Connector must be used. See Additional Authorization List (AAL) for Adapter Connector.

CAUTION

Before you use any cable, make sure the master battery switches and all electrical switches in both the live and dead equipment are in the OFF position. If you attempt to install the cable into live operating equipment, arcing can occur. You can get burned and your cable will be damaged.

CHAPTER 3

OPERATOR/CREW MAINTENANCE INSTRUCTIONS

Section I. CONSUMABLE OPERATING AND MAINTENANCE SUPPLIES

3-1. General

This section contains the consumable maintenance and operating supplies required to operate and maintain the generator set. Refer to Table 3-1.

3-2. Explanation of Columns in the Tabular List of Consumable Maintenance and Operating Supplies

a. Component Application. This column identifies the component application of each maintenance or operating supply item.

b. National Stock Number. This column indicates the National Stock Number assigned to the

item and will be used for requisitioning purposes.

c. Description. This column indicates the item name and brief description.

d. Quantity Required for Initial Operation. This column indicates the quantity of each maintenance or operating supply item required for initial operation of the equipment.

e. Quantity Required for Eight Hours Operation. This column indicates the estimated quantities required for an average 8 hours of operation.

f. Notes. This column indicates informative notes keyed to data appearing in a preceding column.

TM 5-6115-332-14
P-8-614-14
TO 35C2-3-424-1

Table 3-1. Consumable Maintenance and Operating Supplies

| (1) | (2) | (3) | (4) | (5) | (6) |
|----------------------------|-----------------------|---|---------------------------------------|-------------------------------------|---|
| Component application | National stock number | Description | Quantity required F/initial operation | Quantity required F/8 hrs operation | Notes |
| PROTECTIVE MATERIAL | | | | | |
| GENERATOR SET (1) | | GREASE, ALL PURPOSE MIL-G-10924 | | | (1) To be used to coat exposed metal parts. |
| FUEL SYSTEM | | GASOLINE, AUTOMOTIVE: 5 gal (19 liters) pail, as follows: | | | (2) For temperature above 30°F. |
| FUEL TANK (can) | 9130-00-160-1817 | 91A (2) | 5 gal (4) (19 liters) | 10.72 gal (5) (40.7 liters) | (3) Average fuel consumption is 1.34 gph (5.1 liters) in continuous operation. |
| | 9130-00-160-1831 | 91C | 5 gal (4) (19 liters) | 10.72 gal (5) (40.7 liters) | (4) For temperatures consistently below 32°F. (5) As required for cleaning purposes. |
| CLEANING SOLVENT | | | | | |
| GENERATOR SET (5) | 6850-00-274-5421 | CLEANING SOLVENT, 5 gal (19 liters) | | | |

Section II. LUBRICATION INSTRUCTIONS

3-3. General

a. The generator is equipped with a sealed bearing that does not require lubrication.

b. (F) Air Force personnel refer to the lubrication section of applicable TO 35C2-3-1-426 WC-Series Workcards.

3-4. Detailed Lubrication Information

Refer to TM 5-2805-258-14 for detailed lubrication instructions covering the 10 hp MIL-STD Engine.

Section III. PREVENTIVE MAINTENANCE CHECKS AND SERVICES (PMCS)

3-5. General

To insure the generator is ready for operation at all times, it must be inspected systematically so that defects may be discovered and corrected before they result in serious damage or failure. The necessary preventive maintenance services will be performed before operation. Defects discovered during operation will be noted for future correction, to be made as soon as operation has ceased. Stop operation immediately if a deficiency is noted during operation that would damage the equipment if operation were continued. All deficiencies and shortcomings will be recorded, together with the corrective action taken on the applicable form, at the earliest possible opportunity. Marine Corps users should refer to current issue of TM 11275-15/1.

3-6. Operator's Preventive Maintenance Checks and Services

Tables 3-2 list the preventive Checks and Services which must be performed by the operator in the intervals and sequence indicated.

| | |
|-----------|--|
| Class I | Seepage of fluid (as indicated by wetness or discoloration) not great enough to form drops. |
| Class II | Leakage of fluid great enough to form drops but not enough to cause drops to drip from item being checked/inspected. |
| Class 11: | Leakage of fluid great enough to form drops that fall from the item being checked/inspected. |

CAUTION

Equipment operation is allowable with minor leakages (Class I or II). Of course, you must consider the fluid capacity in the item/system being checked/inspected. When in doubt, notify your supervisor.

When operating with Class I or Class II leaks, continue to check fluid levels as required in your PMCS.

NOTE

Leakage definitions for operator/crew PMCS shall be classified as follows:

Table 3-2. OPERATOR/CREW PREVENTIVE MAINTENANCE CHECKS AND SERVICES

B-BEFORE OPERATION
D-DURING OPERATION

A-AFTER OPERATION

| ITEM NO. | INTERVAL | | | ITEM TO BE INSPECTED | PROCEDURES CHECK FOR HAVE REPAIRED OR ADJUSTED AS NECESSARY | EQUIPMENT IS NOT READY/ AVAILABLE IF: |
|--|--------------------------------------|---|--------|---|--|--|
| | B | D | A | | | |
| 1 | • • • • • • • • | | • • | Generator Set | <p>a. Visually inspect the generator set for fuel and oil leaks</p> <p>b. Check engine oil level. Add oil as necessary.</p> <p>c. Check for proper ground connection.</p> <p>d. Inspect for loose, damaged, or missing parts and unusual wear or deterioration. Clean unit as necessary.</p> <p>e. Insure load terminal wires are tightened</p> <p>f. Check battery for tight terminals and missing parts.</p> <p>g. Visually inspect all controls for serviceability before starting generator</p> <p>h. Inspect for cracked or broken welds.</p> | <p>Class III oil or Class I fuel leak is detected.</p> <p>Generator is not properly grounded. Any loose, damaged, or missing parts: (i.e., spark plugs, manifolds, starter, or other items).</p> <p>Loose load terminal wires.</p> <p>Unserviceable or loose battery terminals and missing parts.</p> <p>Loose wire connections or broken meter glass.</p> |
| <p>NOTE</p> <p>Start generator after visual PMCS; insure generator operates as stated in paragraph 2-1.</p> | | | | | | |
| 2 | | | • | <p>Controls and Instruments</p> <p>a. Frequency</p> | <p>Instruments shall indicate within specified limits (para 2-1). 60/400 Hz</p> | <p>Frequency cannot be properly adjusted.</p> |

Section IV. TROUBLESHOOTING

3-7. General

a. This section contains troubleshooting information for locating and correcting operating troubles which may develop in the generator set. Each malfunction for an individual component, unit, or system is followed by a list of tests or inspections which will help you to determine probable causes and corrective actions to take. You should perform the tests/inspections and corrective actions in the order listed.

b. This manual cannot list all malfunctions that may occur, nor all tests or inspections and corrective actions. If a malfunction is not listed or cannot be corrected by listed corrective actions, notify organizational maintenance personnel.

3-8. Operator's Troubleshooting

Refer to table 3-4 for troubleshooting procedures.

NOTE

Before you use this table, be sure you have performed all applicable operating checks.

Table 3-4. Troubleshooting

| MALFUNCTION | TEST OR INSPECTION | CORRECTIVE ACTION |
|--------------------|---------------------------|--------------------------|
|--------------------|---------------------------|--------------------------|

1. STARTER FAILS TO CRANK ENGINE OR CRANKS TOO SLOWLY

- Step 1.** Check to see if the remote-local switch is in the wrong position. Refer to figure 2-3.
If the switch is in the wrong position, simply push it to the desired mode of operation (local or remote). If switch is already in the correct mode of operation, go on to Step 2.
- Step 2.** Check visually for built up corrosion on battery terminals. Move cables slightly to see if they are loose. Refer to fig. 3-1 and tighten connections.
- Low Battery
Refer to paragraph 2-2, figures 2-7 and 2-8.

WARNING

Slave receptacle is to be used when extra cranking power is required for starting unit. Other methods are not authorized!

CAUTION

Be sure that wire brush does not short across terminals or from positive terminal to ground.

If corrosion is present use a soda and water solution to remove the corrosion, then clean terminals with a wire brush.

- Step 3.** Check K4 relay (fig. 1-7) and/or receptacle for broken wiring or loose connections.
Report to organizational maintenance.

Table 3-4. Troubleshooting (Cont'd)

| Malfunction | Test or Inspection | Corrective Action |
|-------------|--------------------|-------------------|
|-------------|--------------------|-------------------|

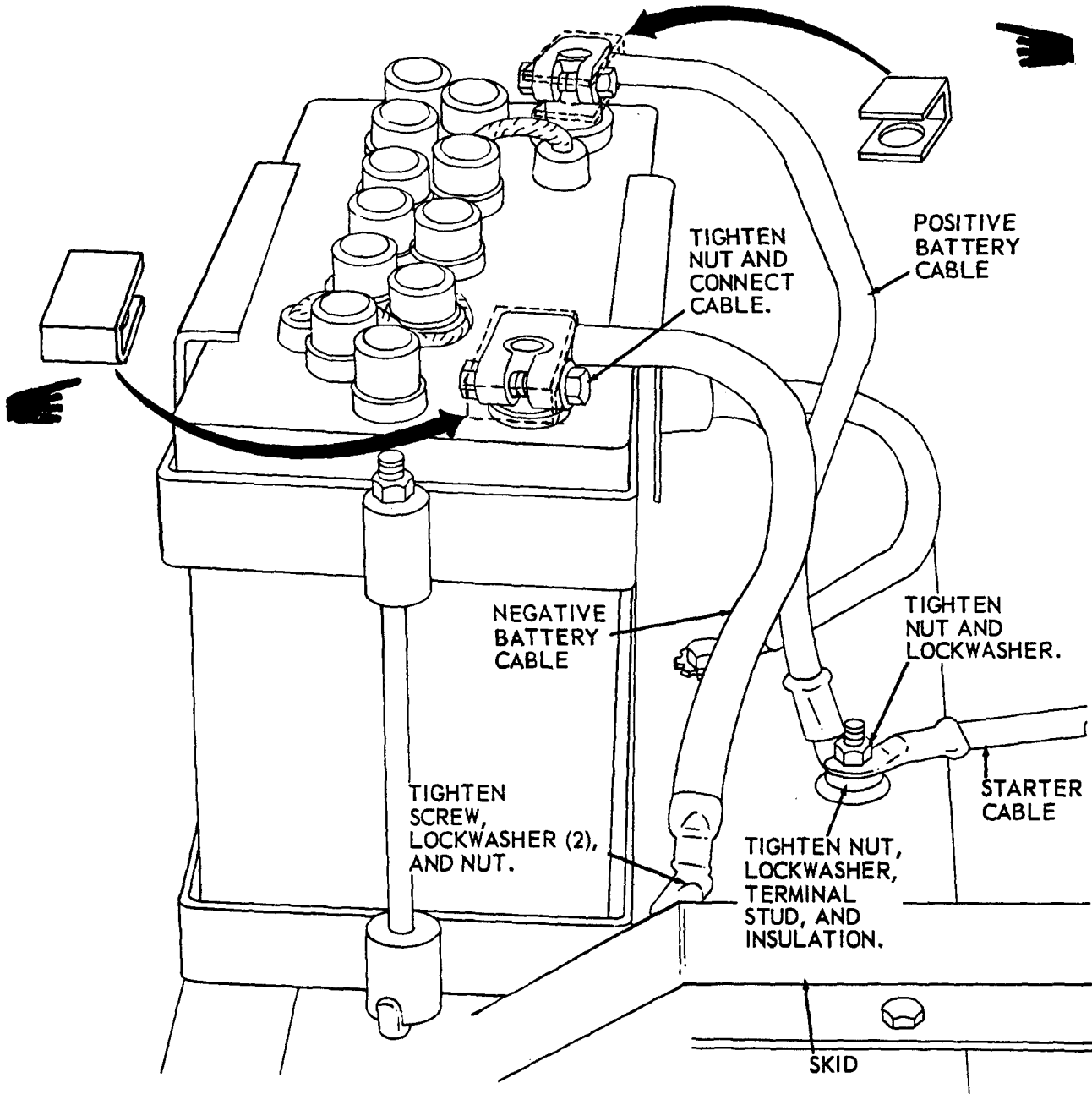

Figure 3-1. Battery cables, starter cable and grommet, and terminal stud.

Table 3-4. Troubleshooting (Cont'd)

| Malfunction | Test or Inspection | Corrective Action |
|--------------------|---------------------------|--------------------------|
|--------------------|---------------------------|--------------------------|

2. GENERATOR FAILS TO SUPPLY POWER TO LOAD

- Step 1.** Check for low generator field by depressing and then releasing the field flash switch, figure 2-5.
If the cause indicates that the generator field is not built up, depressing the switch could resolve the malfunction. Depressing the switch will flash the generator field momentarily with battery current. If this does not resolve the problem, go to Step 2.
- Step 2.** Check for a load cable that is burned, has broken strands, or has insulation worn away. Location will depend upon the external source it is connected to.
If cable is burned, broken, or has no insulation, report the deficiency to organizational maintenance.

3. VOLTMETER FAILS TO SHOW VOLTAGE

- Step 1.** Check for a broken dial and bent indicator. Refer to figure 2-3 for location of the voltmeter.
If the voltmeter has broken dial and bent indicator, refer to organizational maintenance for replacement. The operator, not knowing if the voltmeter is the cause of the malfunction, should go on to Step 2 and isolate another or the only cause of the malfunction.
- Step 2.** If voltmeter is not visually damaged, check for an out-of-adjustment voltage adjusting rheostat which could indicate low or no voltage on the meter.
To correct the above, turn the knob on the rheostat (fig. 2-3) until the proper voltage is attained, as indicated by the voltmeter. If voltage does not build up go on to Step 3.
- Step 3.** If the generator does not build up, check the field flash switch (fig. 2-5).
Momentarily depress the field flash switch. The action could correct the malfunction by flashing the generator field momentarily with battery current. If malfunction is still not corrected, the problem should be reported to organizational maintenance.

4. GENERATOR FAILS TO BUILD UP RATED VOLTAGE

Check the generator field build up by depressing the field flash switch (fig. 2-5).

This action could correct the problem by flashing the generator field with battery current. If depressing switch doesn't correct the problem, report to organizational maintenance.

5. VOLTMETER READING TOO HIGH OR TOO LOW

- Step 1.** Check the voltage adjusting rheostat by visually examining position of knob. Refer to figure 2-3. The rheostat is located just to the right of the center of the control panel.
If the rheostat appears to be in the wrong position, turn it one way first, then turn it the other way. The voltage should increase when the control is turned clockwise. If this does not correct the voltmeter reading, go on to Step 2.
- Step 2.** Refer to figure 2-3 and observe the position of the voltage selector switch. The voltage selector switch is located slightly to the right of center in the upper part of the control panel.
To correct the problem, move the switch to each position until the voltmeter reading is corrected.

Table 3-4. Troubleshooting (Cont'd)

| Malfunction | Test or Inspection | Corrective Action |
|--------------------|---------------------------|--------------------------|
|--------------------|---------------------------|--------------------------|

NOTE

The switch may be bent, broken, rusted or immovable. If this is the case, report to organizational maintenance for replacement.

6. GENERATOR VOLTAGE DROPS WHEN LOAD IS APPLIED OR INCREASED; VOLTAGE FLUCTUATES

Check to see if generator is overloaded. Position the ammeter phase selector switch (fig. 2-3) in each of the three positions in turn, and at the same time observe the current indicator meter (fig. 2-3). The meter should not give an indication greater than 100% in any phase with any type load. With a straight resistive load, such as incandescent lighting, it should not exceed 80% (100% at 1.0 power factor).

If the meter indicates a load greater than these values in any phase, reduce the load. Balance the load on each of the three phases, if possible. Position the voltage selector switch (fig. 2-3) in each of the six positions, in turn, and obtain a voltmeter reading in each of the six positions.

NOTE

If the voltage drops under load, the voltag regulator is defective. Report the condition to organizational maintenance

7. NO POWER AVAILABLE AT OUTLET RECEPTACLE (MODEL MEP-017A)

Check to see if the fuse is burned, broken, or cracked. Open the front of the control box by unlocking the five fasteners located near the top and at the sides of the control panel.

If the fuse has any evidence of the above, replace fuse. Refer to figure 3-2.

Table 3-4. Troubleshooting (Cont'd)

| Malfunction | Test or Inspection | Corrective Action |
|-------------|--------------------|-------------------|
|-------------|--------------------|-------------------|

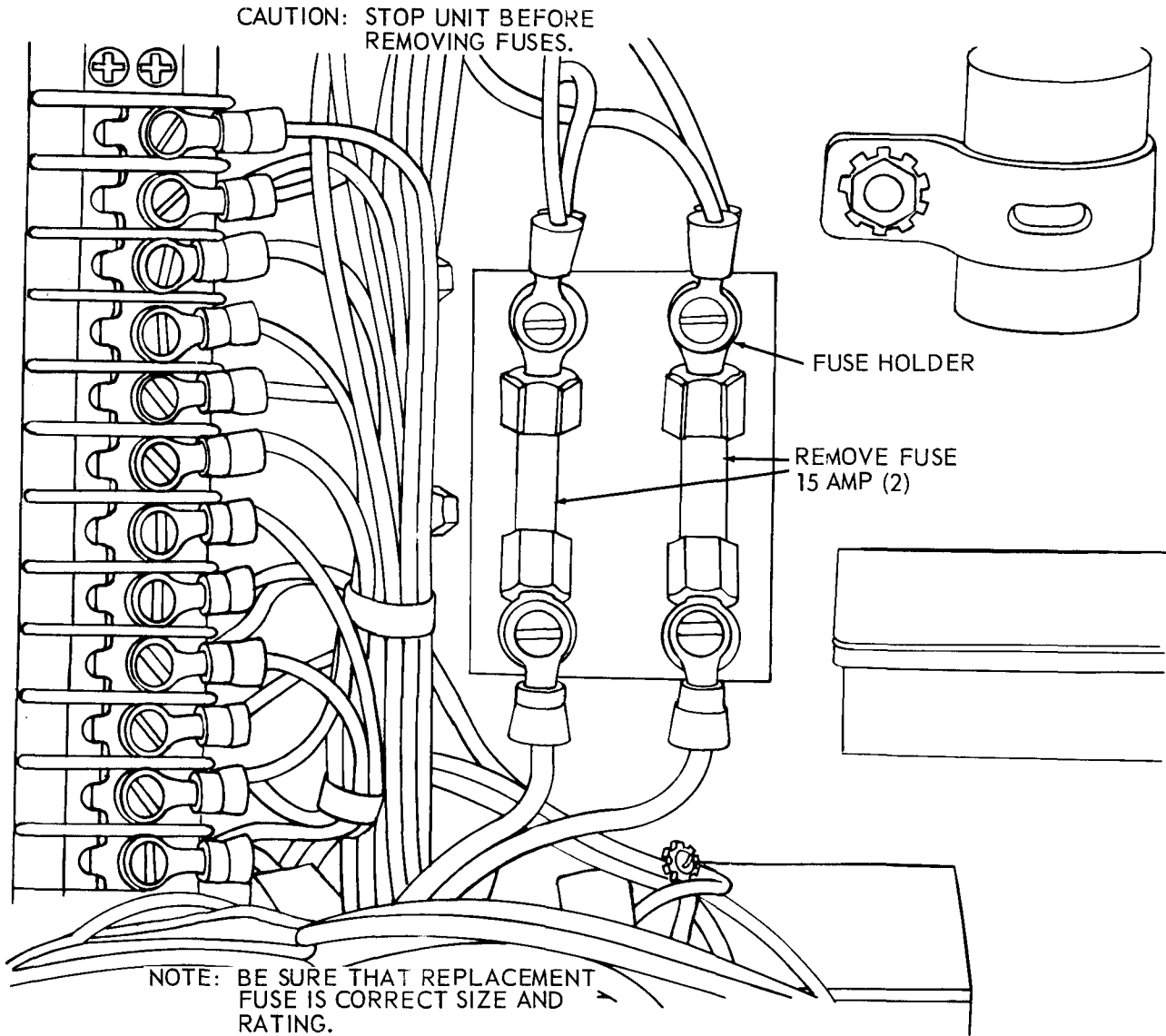

TS6115-332-14/3-2

Figure 3-2. Fuses, removal and installation (MEP-017A).

Table 3-4. Troubleshooting (Cont'd)

| Malfunction | Test or Inspection | Corrective Action |
|--------------------|---------------------------|--------------------------|
|--------------------|---------------------------|--------------------------|

8. GENERATOR OVERHEATS

Step 1. Check to see if the generator is overloaded. Position the ammeter phase selector switch (fig. 2-3) in each of the three positions in turn, and at the same time observe the current indicator meter (fig. 2-3). The meter should not give an indication greater than 100% in any phase with any type load. With a straight resistive load, such as incandescent lighting, it should not exceed 80%, (100% at 1.0 power factor).

If the meter indicates a load greater than the above values in any phase, reduce the load. Balance the load on each of the three phases, if possible. Position the voltage selector switch (fig. 2-3), in each of the six positions, in turn, obtain a voltmeter reading in each of the six positions.

NOTE

If the voltage, drops under load, the voltage regulator is defective. Report the condition to organizational maintenance.

If this procedure does not correct the malfunction, go on to Step 2.

Step 2. Check the shelter where the generator set is located for obstructions that would disrupt air flow. See if there are outlets for heated air and exhaust fumes.

Even though the generator set is weather resistant, it should be located in an adequate shelter that will protect it from inclement weather. Provide a shelter that is ventilated to allow heated air and exhaust fumes to escape. Depending upon the ambient temperature range and upon whether the installation is to be temporary, semi-permanent, or permanent, provide facilities to maintain a reasonable temperature in the area around the unit. If the unit is used in a closed building or other closed shelter, pipe the exhaust gases to the outside.

9. PANEL LIGHTS FAIL TO LIGHT

Check for a broken filament or corroded socket in the lamp.

If lamp is damaged, as above. replace lamp. Refer to figure 3-3.

Table 3-4. Troubleshooting (Cont'd)

| Malfunction | Test or Inspection | Corrective Action |
|-------------|--------------------|-------------------|
|-------------|--------------------|-------------------|

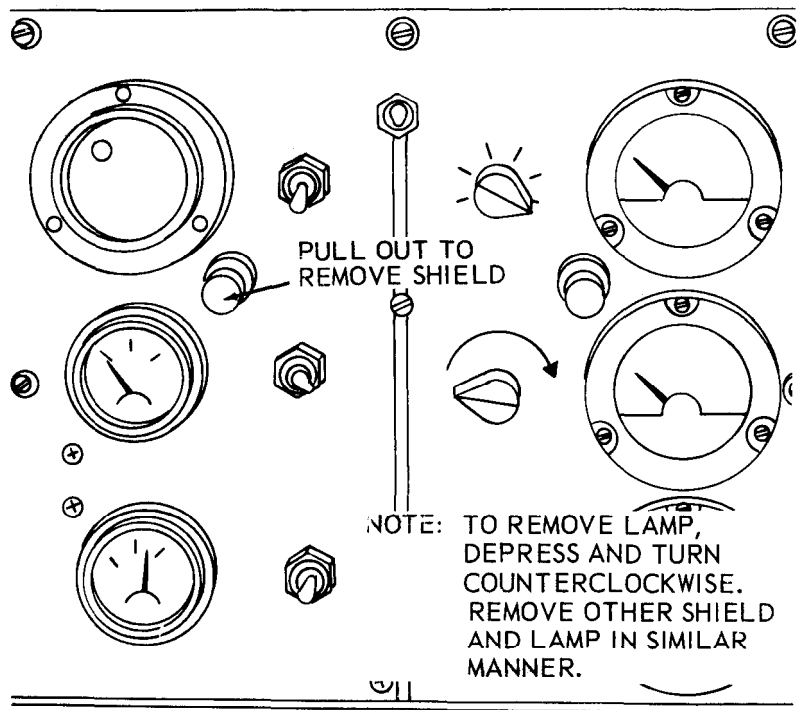

TS 6115-332-14.3-3

Figure 3-3. Panel light lamp, removal and installation.

10. OIL PRESSURE INDICATOR FAILS TO REGISTER OR GIVES LOW READING

Step 1. Check the crankcase oil level. Refer to LO 5-2805-258-12 for location of crankcase oil fill and level cap.
If oil is low, fill crankcase to full level as stated in LO 5-2805-258-12. If oil is not low, go on to Step 2.

Step 2. Check the oil pressure indicator for broken dial, bent indicator hand, or bad connections. The oil pressure indicator (fig. 2-3) is calibrated from 0 to 60 psi (4.2 kg per sq cm). Located at the left center of the control panel, it indicates the engine oil pressure. The normal readings range from 20 psi (1.4 kg per sq cm) at approximately 1/4 rated speed to a maximum of 60 psi (4.2 kg per sq cm) at rated governed speed.
If the indicator is damaged, as stated above, report to organizational maintenance.

Section V. OPERATOR/CREW MAINTENANCE INSTRUCTIONS

3-9. General

This section provides maintenance instructions that apply to the personnel that are responsible for the operation of the generator set. Unless otherwise specified, these instructions apply to both the Model MEP-017A and the Model MEP-022A generator sets.

WARNING

Always shut down the equipment before performing any maintenance operations on components of the electrical system. Failure to observe this warning can lead to death by electrocution.
lzl

3-10. OIL DRAIN ASSEMBLY AND MUFFLER

a. Inspect oil drain and muffler for cracks, holes and wear.

b. For replacement, report to organizational maintenance.

3-11. Fuel System

a. Inspect fuel can, lines, strap, adapter, and selector valve for damage.

b. For removal and installation of fuel can, refer to figure 3-4 and the following instructions.

(1) Removal.

(a) Lift locking handle on the fuel can adapter and remove the fuel can adapter.

(b) Lift clamp to loosen strap and remove strap from buckle.

(c) Remove fuel can.

(2) Installation.

(a) Position fuel can in place and secure by tightening strap. Depress clamp to lock strap in place.

(b) Place fuel can adapter in tank and secure by depressing locking handle.

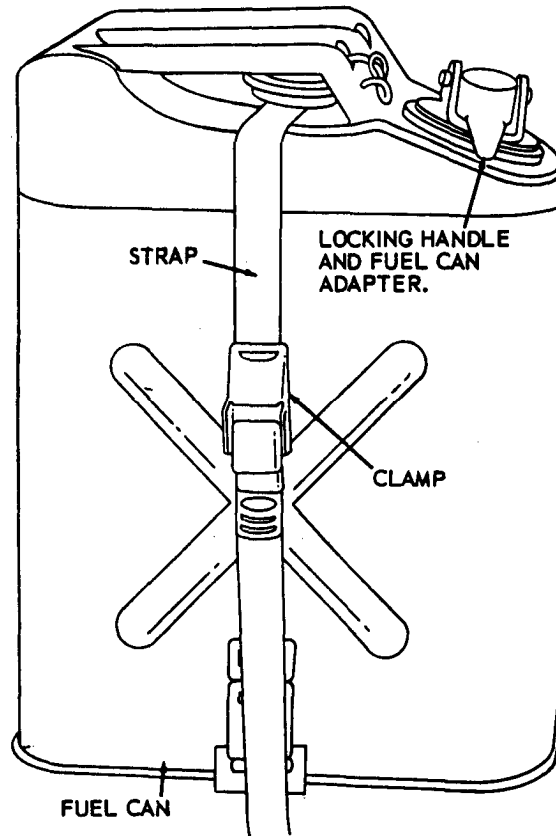

Figure 3-4. Fuel can, removal and installation.

3-12. Electrical System

- a. Inspect the battery cable, hold down frame, starter cable, and slave receptacle for damage.
- b. For replacement, report to organizational maintenance.

3-13. Battery

- a. *Inspection.* Inspect battery for cracks and for proper electrolyte level.
- b. *Service.*

WARNING

When servicing the battery, do not smoke or use an open flame in the vicinity. Batteries generate a highly explosive gas.

NOTE

The 6TN and 6TL batteries can be mixed or matched. However, maintenance-free batteries cannot be mixed or matched with military batteries. The 6TN and or the 6TL batteries will perform properly in hot weather as long as electrolyte levels are carefully monitored. If the electrolyte expands and causes the level to rise, some fluid must be removed. If the level becomes too low due to evaporation, distilled water may be

used to obtain the proper level. A good grade of drinking water (excluding mineral waters) may be used if distilled water is not available.

Electrolyte (NSNs 6810-00-249-9354 and 6810-00-843-1640) have a specific gravity of 1.280 and should be used in these batteries. Do NOT adjust the electrolyte in wet batteries to a lower specific gravity.

Remove the battery vent caps and fill each cell of the battery to the proper level with distilled water. The correct level is 3/8 inch (0.95 cm) above the plates. Install the vent caps.

- c. Utilize slave receptacle to supply external power for charging batteries and extra cranking power.

3-14. Control Box Assembly

a. Removal.

- (1) Open the front of the control box by unlocking the five fasteners located near the top and at the sides of the control panel.
- (2) For removal of fuse (Model MEP-017A), refer to figure 3-2.
- (3) For removal of the lamps, refer to figure 3-3.

- b. *Cleaning.* Clean the fuses and the lamps with a clean, lint free cloth.

c. Inspection. Inspect the fuses, lamps, and the following control box components for breaks, wear, corrosion, and other defects.

- (1) Incandescent lamps (fig. 3-3).
- (2) Panel light assembly (fig. 2-3).
- (3) Time totalizing meter (fig. 2-3).
- (4) Battery charging ammeter (fig. 2-3).
- (5) Oil pressure indicator (fig. 2-3).
- (6) Toggle switch (fig. 2-3).
- (7) Voltage selector switch (fig. 2-3).
- (8) Voltage adjusting resistor (fig. 2-3).
- (9) Ammeter phase selector switch (fig. 2-3).
- (10) AC voltmeter (fig. 2-3).
- (11) AC current meter (fig. 2-3).
- (12) Frequency indicator (fig. 2-6).
- (13) Fuse holder (fig. 3-2).
- (14) Circuit breaker (fig. 2-3).
- (15) Voltage regulator (fig. 5-2).
- (16) Relay panel assembly (fig. 5-1).
- (17) Armature relay (fig. 4-32).
- (18) Current transformer (fig. 5-1).
- (19) Remote control board assembly (fig. 2-9).
- (20) Load terminal (fig. 4-35).
- (21) Load terminal board assembly (fig. 4-35).
- (22) Outlet receptacle (fig. 4-29).
- (23) Radio interference suppression capacitor (fig. 4-20).
- (24) Lower and upper vibration mount (fig. 4-30).

(25) Control box bracket (fig. 4-32).

(26) Control panel assembly (fig. 2-3).

d. Installation.

(1) Install the lamps, refer to figure 3-3.

(2) Install the fuses, refer to figure 3-2.

(3) Lock the fasteners on the control box, refer to figure 2-3.

3-15. Generator Assembly

a. Inspection.

(1) Inspect the generator for cracks, breaks, and other damage.

(2) Inspect the air intake grille (fig. 6-3) for breaks, tears and wear.

b. Service.

(1) Perform the operator's preventive maintenance checks and services, Tables 3-2 and 3-3.

(2) Remove all tape and tags, cloth, and other barrier material.

(3) Correct all deficiencies that are found or report the condition to organizational maintenance.

3-16. Frame Assembly

a. Inspect the frame guard, lifting bracket, grounding stud, skid base assembly, toolbox and plates for wear, cracks, breaks and other damage.

b. If replacement is required, report to organizational maintenance.

CHAPTER 4

ORGANIZATIONAL MAINTENANCE INSTRUCTIONS

Section I. SERVICE MAINTENANCE INSTRUCTIONS

4-1. Inspecting and Servicing the Equipment

WARNING

a. *Inspecting the Equipment.*

(1) Inspect the identification plate for positive identification of the generator set.

(2) Make a thorough inspection of the generator set for any damage that may have occurred during shipment.

(3) Compare the equipment with the packing list to make certain that all items are accounted for and are in serviceable condition.

(4) Inspect the entire unit carefully for loose and missing hardware.

(5) Turn the engine over by hand to make certain that all moving parts in the engine and generator move freely.

(6) Correct all deficiencies. All deficiencies noted beyond the responsibility of organizational maintenance shall be reported to Direct Support maintenance.

b. *Servicing the Equipment.*

(1) Unit Service.

(a) Perform the weekly, monthly, and semi-annual preventive maintenance services (table 4-2).

(b) Remove all tags and tape, cloth, and other barrier material.

(c) (A, MC) Lubricate the engine of the generator set in accordance with the instructions in the current lubrication order for the engine, refer to TM 5-2805-258-14. (F) Air Force personnel refer to the lubrication section of applicable TO 35C2-3-1-426 WC Series Workcards.

(d) Correct all deficiencies that are found or report the condition to direct support maintenance.

(2) Battery Service.

When servicing the battery, do not smoke or use an open flame in the vicinity. Batteries generate a highly explosive gas. Use extreme care when handling electrolyte. Electrolyte contains sulfuric acid and will cause severe burns upon contact with the skin. If electrolyte comes in contact with the skin, clothing, or painted surfaces, immediately flush the area with water to wash away all traces of acid.

(a) The electrolyte for the battery is shipped in a separate container. When the unit is ready for operation, unpack the electrolyte, remove the battery vent caps, and fill each cell of the battery to the proper level with electrolyte. The correct level is 3/8 inch (0.95 cm) above the plates. Install the vent caps.

(b) Install the battery cables, making certain that the correct polarity is observed.

4-2. Installation

a. *Procedure.*

(1) General. The generator set is normally shipped from the depot or supply point in an operationally ready condition, except that it is drained and preserved. Before any attempt is made to operate the unit, service it. Pay particular attention to any attached tags, decals, or notices. Set up the

unit for operation as described in the subparagraphs that follow:

(2) Site Selection. Consider the following factors when selecting and preparing an installation site for the generator set.

(a) *Distance to Load.* To reduce transmission line voltage losses, position the generator set as close as is reasonably possible to the load.

(b) *Shelter.* Even though the generator set is weather resistant, it should be located in an adequate shelter that will protect it from inclement weather. Provide a shelter that will protect it from inclement weather. Provide a shelter that is ventilated to allow heated air and exhaust fumes to escape. Depending upon the ambient temperature range and upon whether the installation is to be temporary, semi-permanent, or permanent, provide facilities to maintain a reasonable temperature in the area around the unit. If the unit is used in a closed building or other closed shelter, pipe the exhaust gases to the outside.

When a spark arrester is required the installation procedure will be on the instruction sheet furnished with the spark arrester kit located on page 25, TM 5-6115-332-24P.

WARNING

The United States Forestry Service requires that any engine driven equipment operating within National Forests or Parks be provided with spark arresters for the avoidance of forest fires.

WARNING

Do not operate the generator set in an enclosed building unless the exhaust gases are piped to the outside. Exhaust gases contain carbon monoxide, a poisonous, odorless, colorless gas.

(c) *Access.* Provide enough clearance around the generator set to facilitate operation and maintenance activities.

(d) *Fuel Supply.* Provide an adequate supply of clean fuel to meet requirements based on operation time. Consider installation of the tanks underground if the installation will be longer than temporary. Locate the tanks as near the shelter as practicable and be certain that the bottoms of the tanks are not lower than four feet (120 cm) from the fuel pump on the installed generator set. Connect the fuel line from the external source to the fuel selector valve. Provide for the exclusion of dirt and moisture.

(e) *Support.* Be certain that the bearing surface used can support the weight of the generator set.

(f) *Foundation.* Since the unit is of the portable type, no foundation should normally be required. However, position the unit on reasonable firm, dry ground using planks, timbers, or a suitable gravel base, as available conditions warrant. Provide for water drainage away from the unit.

(g) *Mounting.* Position the unit so that it is level in both planes and so that the frame is supported on its entire bottom surface. If necessary, the frame may be secured to a suitable base.

(3) *Electrical Connections.* All internal electrical connections for proper operation of the generator sets have been made at the time of manufacture. If it appears that changes have been made in the wiring, refer the matter to Direct Support Maintenance.

(a) *Power Transmission Cables.* Use cable with a minimum wire size of No. 8 AWG. This size will give a voltage drop of about 1 volt per 25 feet (750 cm) of cable when the unit is operated at full load. If the distance to the load is great, increase the wire size to No. 6 to No. 4 to minimize voltage drop.

WARNING

Before attempting to connect the load cables, make sure the generator set is completely shut-down.

(b) *Power Output Connection.*
Position the circuit breaker in the OFF position and connect the load transmission cables to the load terminals of the load terminal board (figs. 1-1 and 1-3), in accordance with the output voltage and phase requirements, as shown by table 4-1. Refer to figure 2-4 for the output selector switch.

Table 4-1. Output Selector Switch Positions and Load Cable Connections (1).

| Switch Position | Generator Output | Cable Connections |
|-----------------|----------------------------|-------------------|
| 1 | 240 V, 1 phase, 2 wire | L2 and L3 |
| 2 | 120 V, 1 phase, 2 wire | L2 and L3 |
| 3(2) | 120 V, 3 phase, 3 wire | L1, L2, and L3 |
| 4(2) | 120/208 V, 3 phase, 4 wire | LO, L1, L2 and L3 |

(1) Switch positions are found by facing the switch. For No. 1 position, turn the knob clockwise to the limit of its travel. Switch positions 2,3, and 4 may then be found by turning the knob counterclockwise.

(2) When connecting for a 3-phase, 3-wire, or 3-phase, 4-wire operation, the phase sequence may be incorrect on some equipment causing motors to run backward. If the sequence is found to be incorrect, switch positions of any two of the load leads either L1, L2, and L3. Do not switch load lead LO.

(c) Ground Connections.

(See Chap. 2-2, para. C)

b. Revetment Construction

(1) General. The generator sets are designed to be operated in the open, with unrestricted ventilation. In some situations, however, it may be necessary to operate the equipment under the protection of a revetment. This subparagraph provides information on the major details applicable to the construction of a revetment, should it be necessary.

(2) Dimensions.

(a) The minimum inside dimensions and height are shown by figures 4-1 and 4-2.

(b) The entrance of the revetment, shown by figure 4-3 should be 0.6 meter (2.0 feet) wide with a sill at the bottom not higher than 0.3 meter (1.0 foot). The minimum dimensions given here are based solely on considerations applicable to engine cooling and ventilation, with an allowance made for the minimum practicable space for service and maintenance.

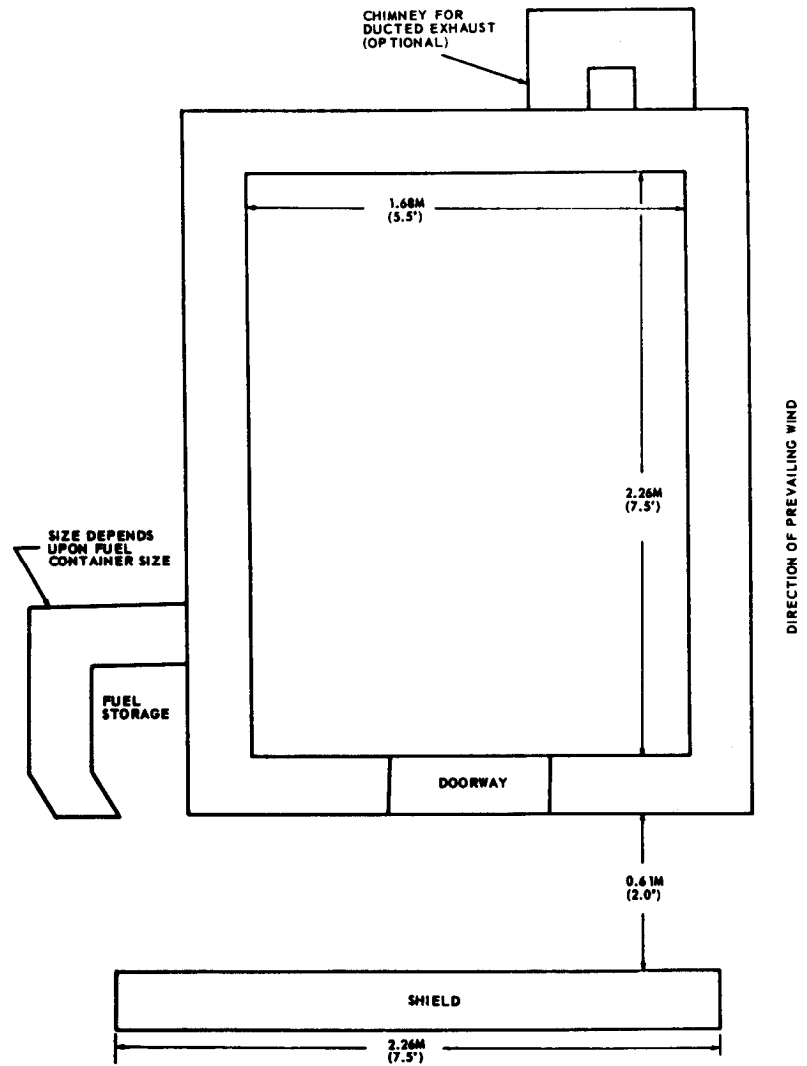

Figure 4-1. Revetment, top plan view.

TM 5-6115-332-14
P-8-614-14
TO 35C2-3-424-1

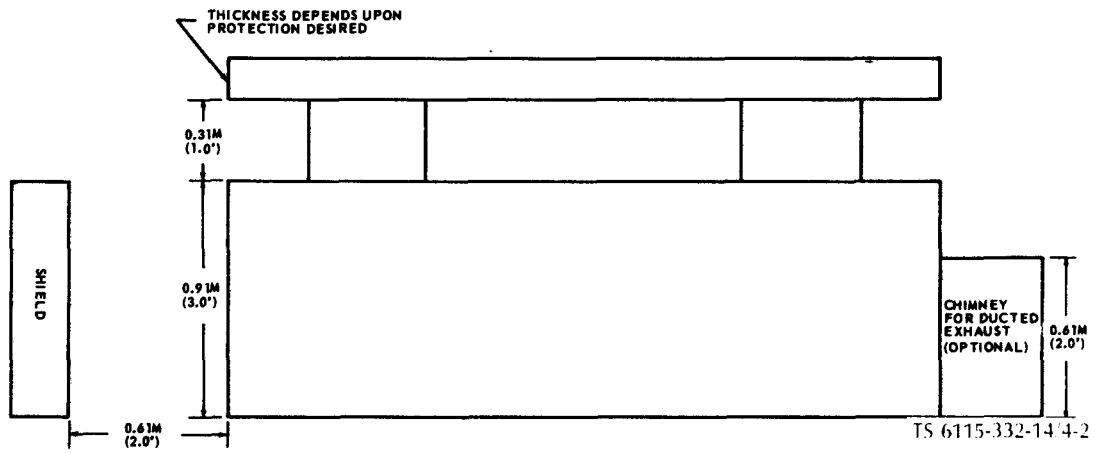

Figure 4-2. Revetment, side plan view.

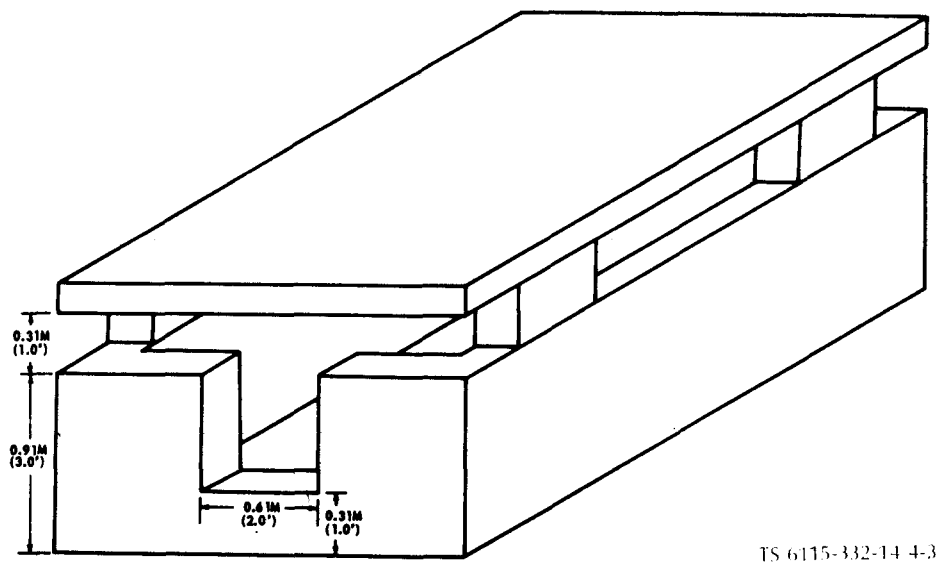

Figure 4-3. Revetment, isometric plan view

(3) Foundation and Drainage. If the generator set is attached to a shipping pallet, the pallet will provide an adequate foundation. If not, use planks, timbers, logs, ammunition boxes, or other available material to prevent the skids of the frame from sinking into soft earth or sand. In no case should the foundation exceed a height of 6 inches (15.2 cm) nor should the generator set be tilted at an angle of more than 15 degrees in any direction. Provide drainage to ensure runoff of any water in a direction away from the generator set and out of the revetment through drain holes located at the inside ground level. Where there is no natural slope for the water to run away from the revetment, provide a sump and drainage trench for each drain hole in a location outside of the revetment.

(4) Wall Construction. The walls of the revetment may be constructed of sand bags, ammunition boxes filled with sand or dirt, or any other material available. The wall height should not exceed

0.9 meter (3.0 feet), as shown by figure 4-3 and the walls should be constructed as shown by figure 4-4.

(5) Roof Construction. The roof may be supported by any means available, but should be 0.3 meter (1.00 foot) above the wall of the revetment and should provide as much open space around the top of the wall as possible. Refer to figures 4-2, 4-3, 4-4, 4-5, and 4-6. Preferred materials for use in roof construction consists of 2 pieces of lumber (4 x 4 inches) (10.2 cm) or logs (4 inches in diameter) (10.2 cm) meters (10.0 feet) long, and the necessary cross pieces of lumber, logs, or steel plating to cover the entire roof area as shown by figure 4-6. These cross pieces should be about 2.4 meters (8.0 feet) long. If the above materials are not readily available, any available material of a similar nature may be used. The thickness of the roof (figs. 4-2 and 4-5) will depend upon the amount and type of protection desired. Take care to ensure that the roof is properly supported to carry the additional weight, when adding additional protective material.

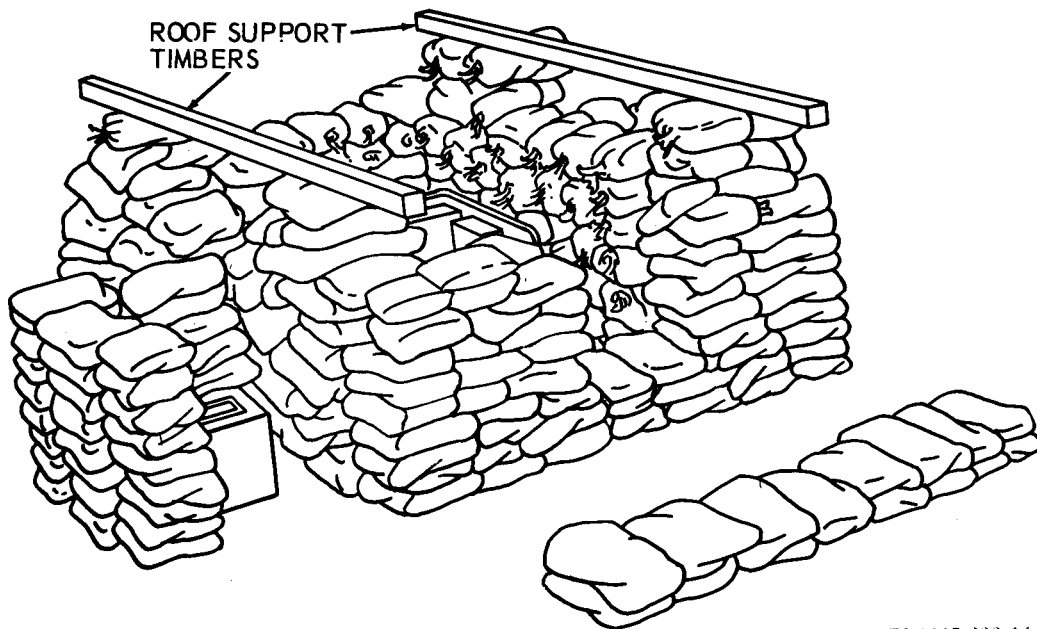

TS 6115-332-14 4-4

Figure 4-4. Revetment, perspective without roof.

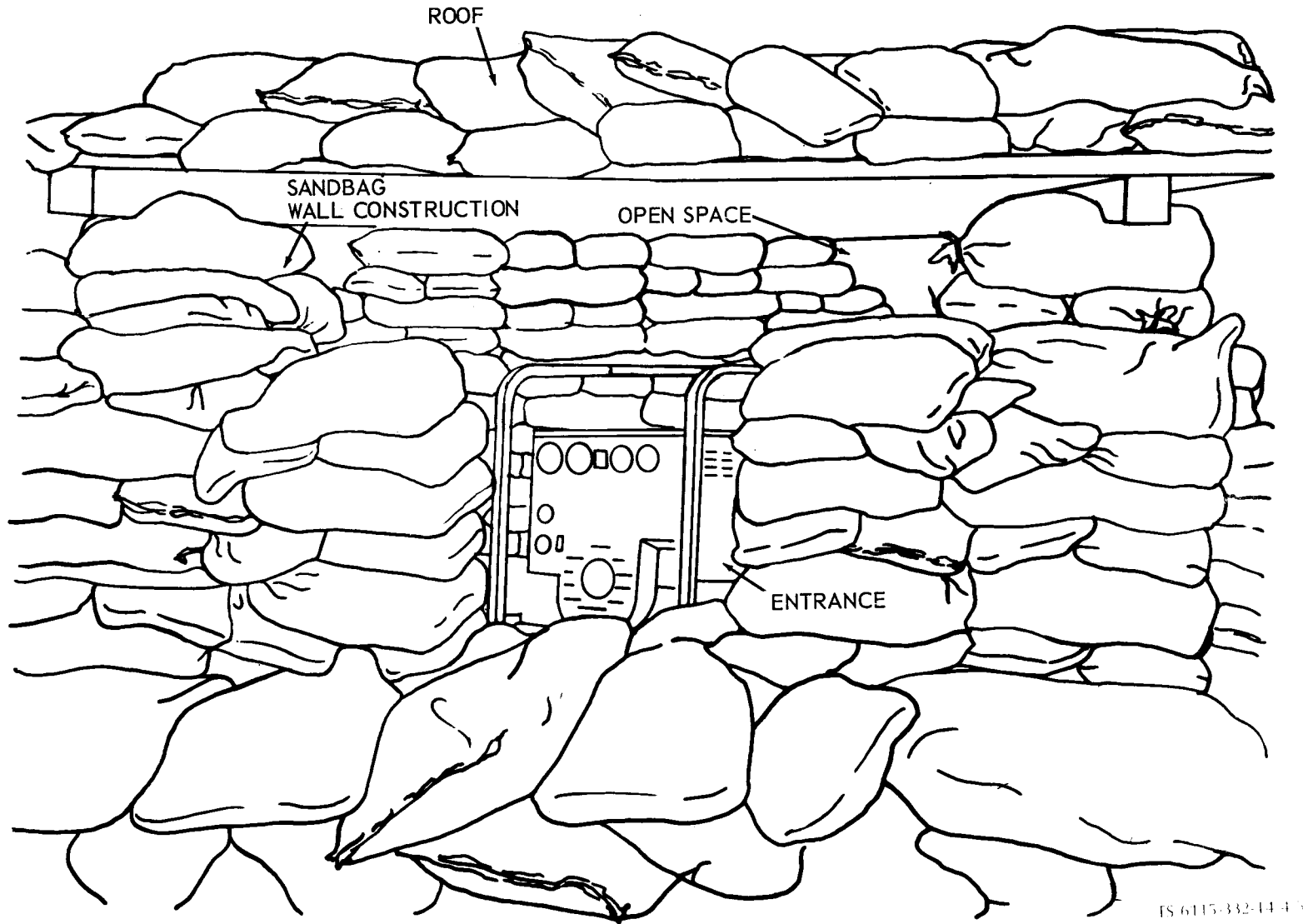

Figure 4-5. Revetment, front view.

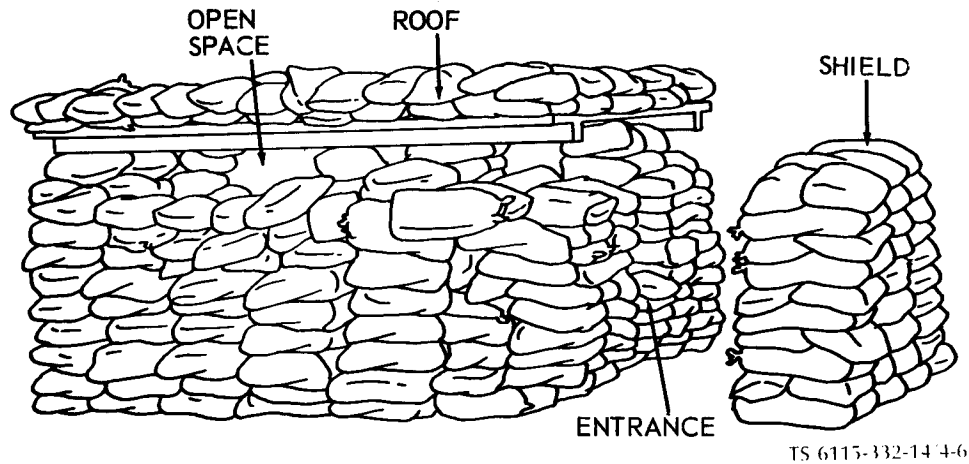

Figure 4-6. Revetment, left side view.

(6) Miscellaneous Construction. Construct a compartment for fuel storage outside of the revetment, as shown by figure 4-1 and 4-4. The size of the fuel storage area will depend upon the size of the fuel container to be used. Since the temperature within the revetment will build up considerably above the outside ambient temperature, when the generator set is operating, always locate the fuel supply outside the revetment to minimize the hazard associated with gasoline stored at high temperatures. For the same reason, it is recommended that the fuel can located on the generator set not be used when the generator set is used in a revetment or a revetted area. Pipe the exhaust gases from the engine to the outside of the revetment. The installa-

tion should be similar to that shown by figure 4-7. If flexible pipe is not available for use in exhaust extension, a piece of exhaust pipe or other similar pipe may be used. The point at which the exhaust discharge will go through the revetment will depend entirely upon the material that is available. The exhaust gases may or may not be discharged into an external exhaust chimney constructed as shown by figure 4-1. Such a chimney aids in carrying the exhaust gases away from the revetment and will reduce the noise level. Construct a revetment doorway shield, as shown by figures 4-1, 4-2 and 4-6. This shield is to be a wall, 0.9 meter (3.0 feet) high and 2.3 meters (7.5 feet) long, constructed in a manner similar to the revetment walls to prevent the direct entrance of projectiles or fragments.

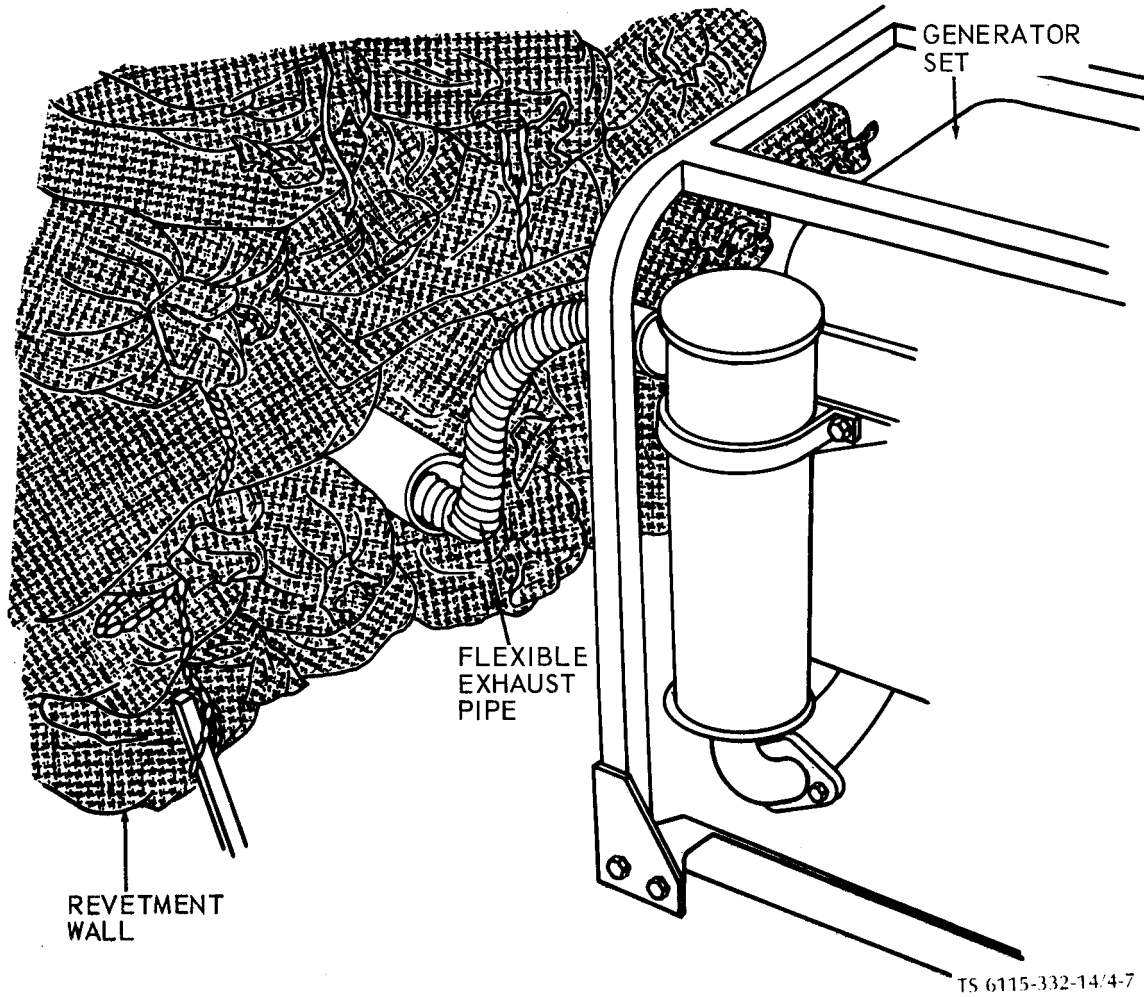

Figure 4-7. Revetment, exhaust piping.

(7) Orientation Instructions. When constructing the revetment, the orientation of the structure will be such that its entrance will face the prevailing wind (fig. 4-1). The generator will be centered within the revetment and will be positioned so that the long axis of the generator set is parallel to the long axis of the revetment. In addition, the generator end of the generator set will be positioned next to the entrance. These instructions are very important and will be observed so that

proper cooling and ventilation will be obtained when the unit is operated in a revetment.

(8) Multiple-Unit Installation. No more than one generator set will be operated in a revetment. Also, no other heat generating equipment will be placed in a revetment with a generator set.

4-3. Equipment Conversion.

For conversion of the generator set to a different voltage or phasing requirement, refer to figure 2-4 and to table 4-1.

Section II. MOVEMENT TO A NEW WORKSITE

4-4. Dismantling for Movement.

a. Preparation for Movement.

(1) Stop the generator set as follows:

(a) Local Mode Stopping. Refer to figure 2-10 for local mode stopping instructions.

(b) Remote Mode Stopping. To stop the generator set from a remote position, make contact between the stop terminal and common terminal of the remote control terminal board (fig. 2-9). As soon as the unit stops, break contact.

(2) Disconnect the load cable and ground cable.

(3) Disconnect the auxiliary fuel hose and exhaust piping, as applicable.

(4) Remove all anchoring devices.

(5) See that all tools and equipment assigned to the unit are clean and are in serviceable condition.

b. Handling Equipment.

(1) If the site for operation is reasonably close, the generator set may be carried or skidded.

(2) If the generator set is to be transported by carrier, see that it is properly blocked and tied down to prevent damage by its shifting during transit.

4-5. Reinstallation after Movement.

The instructions for reinstallation after movement are the same as outlined in paragraph 4-2.

Section III. REPAIR PARTS, SPECIAL TOOLS AND EQUIPMENT

4-6. Tools and Equipment.

Tools, equipment, and repair parts that are issued with or authorized for the generator set are listed in the basic issue items list.

4-7. Special Tools and Equipment.

No special tools or equipment will be required by organizational maintenance for the maintenance of the generator sets.

4-8. Maintenance Repair Parts.

(A) Repair parts and equipment are listed and illustrated in the repair parts and special tool list covering the generator set, TM 5-6115-332-34P. For engine repair parts, refer to TM 5-2805-258-24P.

(F) Air Force users refer to TO 38G2-89-34.

TM 5-6115-332-14
P-8-614-14
TO 35C2-3-424-1

Section IV. LUBRICATION INSTRUCTIONS

4-9. General.

The generator is equipped with a sealed bearing that does not require lubrication.

4-10. Detailed Lubrication Information.

Refer to TM 5-2805-258-14 for detailed lubri-

cation information on the MIL-STD Engines.

4-11. Air Cleaner Service.

Refer to TM 5-2805-258-14 to service the air cleaner.

Section V. PREVENTIVE MAINTENANCE CHECKS AND SERVICES (PMCS)

4-12. General.

a. The generator set shall be inspected and serviced to ensure that it is ready for use at all times. The necessary weekly, monthly, and semi-annual preventive maintenance services to be performed are listed in table 4-2. The item numbers indicate the sequence of the minimum inspection requirements. All faults noted during the inspection or service will be recorded on DA Form 2404. TM 38-750 should be consulted for complete information on use of DA Form 2404.

b. Defects discovered during operation will be noted for future correction. Stop operation immediately if a deficiency is noted which would damage the equipment. All deficiencies and shortcomings will be recorded together with the corrective actions taken on the applicable form. Air Force users shall refer to the applicable inspection manuals and work

card sets in the TO 35C2-3-1-426 series for periodic requirements and table 4-2 for detailed procedures. Marine Corps users should refer to current issue of TM 11275-15/1.

c. (A, N, MC) Preventive Maintenance Checks and Services.

Table 4-2 contains a tabulated listing of PMCS which shall be performed by the Organizational personnel. The item numbers are listed consecutively and indicate the sequence of minimum requirements.

4-13. Organizational Maintenance Preventive Maintenance Checks and Services.

For preventive maintenance checks and services that are applicable to organizational maintenance, refer to table 4-2.

Table 4-2. ORGANIZATIONAL PREVENTIVE MAINTENANCE CHECKS AND SERVICES

| ITEM NO. | INTERVAL | | | ITEM TO BE INSPECTED | PROCEDURES CHECK FOR HAVE REPAIRED OR ADJUSTED AS NECESSARY | EQUIPMENT IS NOT READY/ AVAILABLE IF: |
|----------|----------|---|----|----------------------|--|---------------------------------------|
| | W | M | H | | | |
| 1 | | • | | Battery | Check battery electrolyte level. Perform a hydrometer check of the battery electrolyte prior to adding water (use distilled water if available). Recharge or replace battery if specific gravity is low. Clean battery connections as necessary (para 3-13). | |
| 2 | • | | | Fuel filter | Remove and dean fuel filter and sediment bowl (fig. 3-3, TM 5-2805-2581 4). | |
| 3 | | | 50 | Engine oil | Change lubricating oil every 50 hours (LO 5-2805-258-14) | |
| 4 | | | 50 | Oil filter | Replace lubricating oil filter every 50 hours (fig. 3-1, TM 5-2805-258-14). | |

Section VI. TROUBLESHOOTING

4-14. General.

a. This section contains troubleshooting information for locating and correcting most of the operating troubles which may develop in the generator set. Each malfunction for an individual component, unit, or system is followed by a list of test or inspections which will help you to determine the probable causes and corrective actions to take. You should perform the test/inspections and corrective actions in the order listed.

b. This manual cannot list malfunctions that may occur, nor all tests or inspections and corrective actions. If a malfunction is not listed or is not corrected by listed corrective actions, notify your supervisor.

4-15. Organizational Troubleshooting.

Refer to table 4-3 for organizational troubleshooting.

NOTE

Before you use this table, be sure you have performed all applicable operating checks.

4-16. General Instructions for use of Multimeters.

a. *Introduction.* In electrical troubleshooting, the Simpson 160, the TS-352B/U, and the AN/URM-105 will do the same job. Therefore, your shop sets may contain any one of these multimeters (fig. 4-8). Any of these three multimeters can be used to troubleshoot your equipment's electrical system. This section shows how.

TM 5-6115-332-14
P-8-614-14
TO 35C2-3-424-1

SIMPSON 160
NSN 6625-00-935-1333

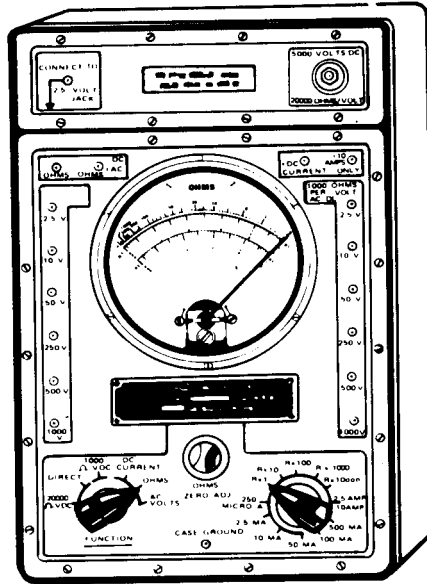
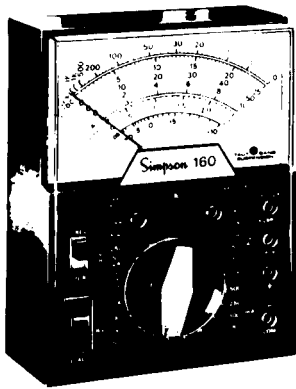

TS-352B/U
NSN 6625-00-553-0142

AN/URM-105
NSN 6625-00-999-6282

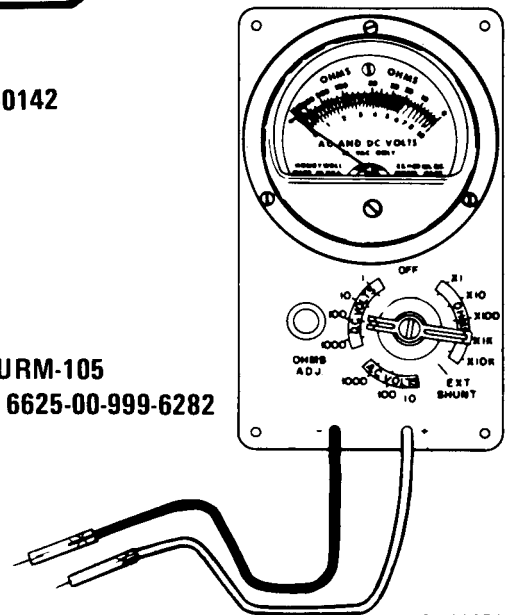

TS 022251

Figure 4-8. Types of multimeters.

NOTE

The Simpson 160 is only available in new shop sets as a substitute for the TS-352B/U or AN/URM-105.

b. Using the Ohms Scale. The ohms scale is used to make tests for continuity, shorts and

resistance.

(1) **“Zeroing” the Meter (Figure 4-9).** The multimeter must be set up and “zeroed” before making these tests. Do the following steps that match the multimeter you have:

AN/URM-105

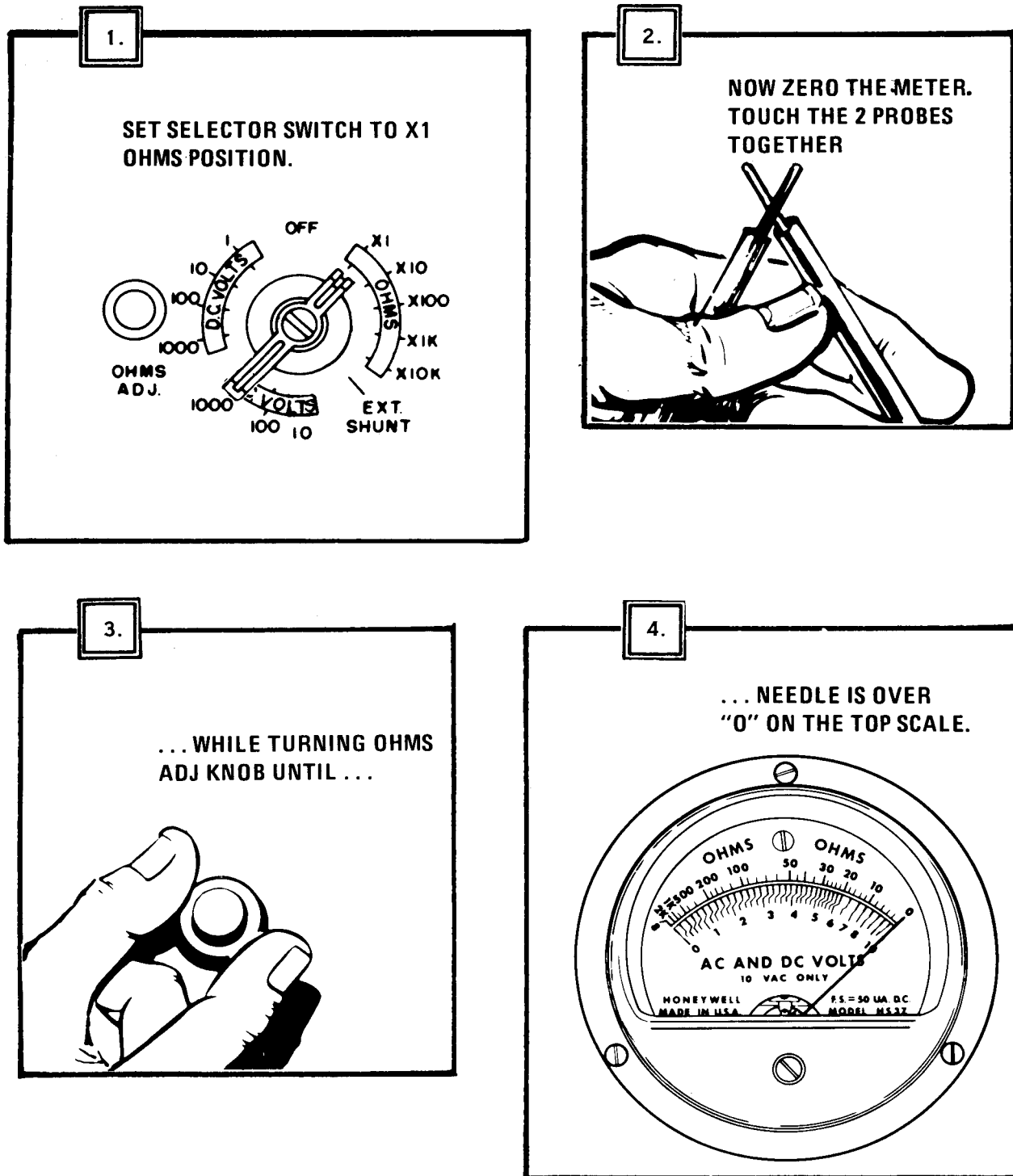

TS 022252

Figure 4-9. "Zeroing" the multimeters.

(Sheet 1 of 3).

TS-352B/U

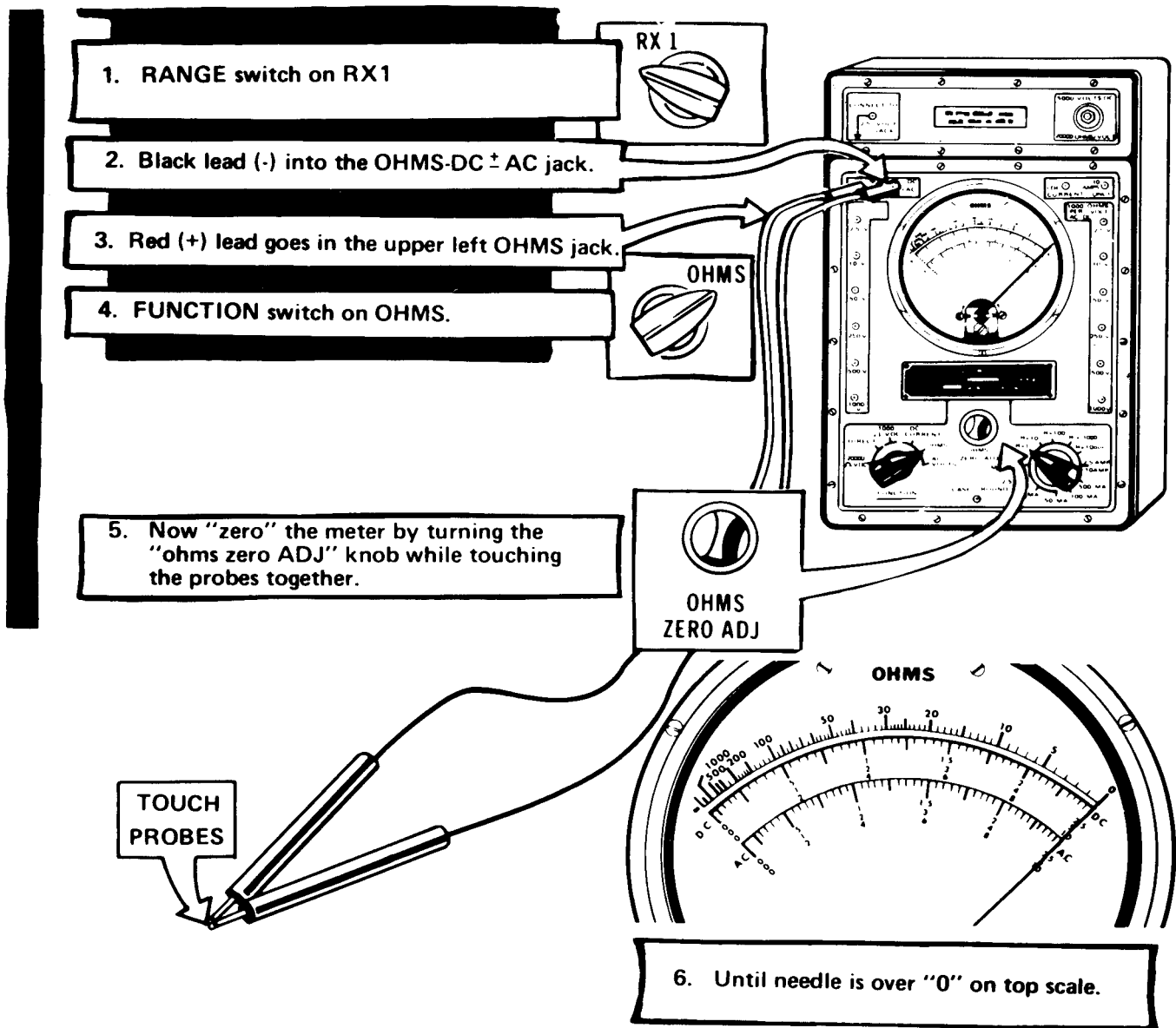

TS 022253

Figure 4-9. "Zeroing" the multimeters.
(Sheet 2 of 3)

TOUCH THE 2 PROBES TOGETHER

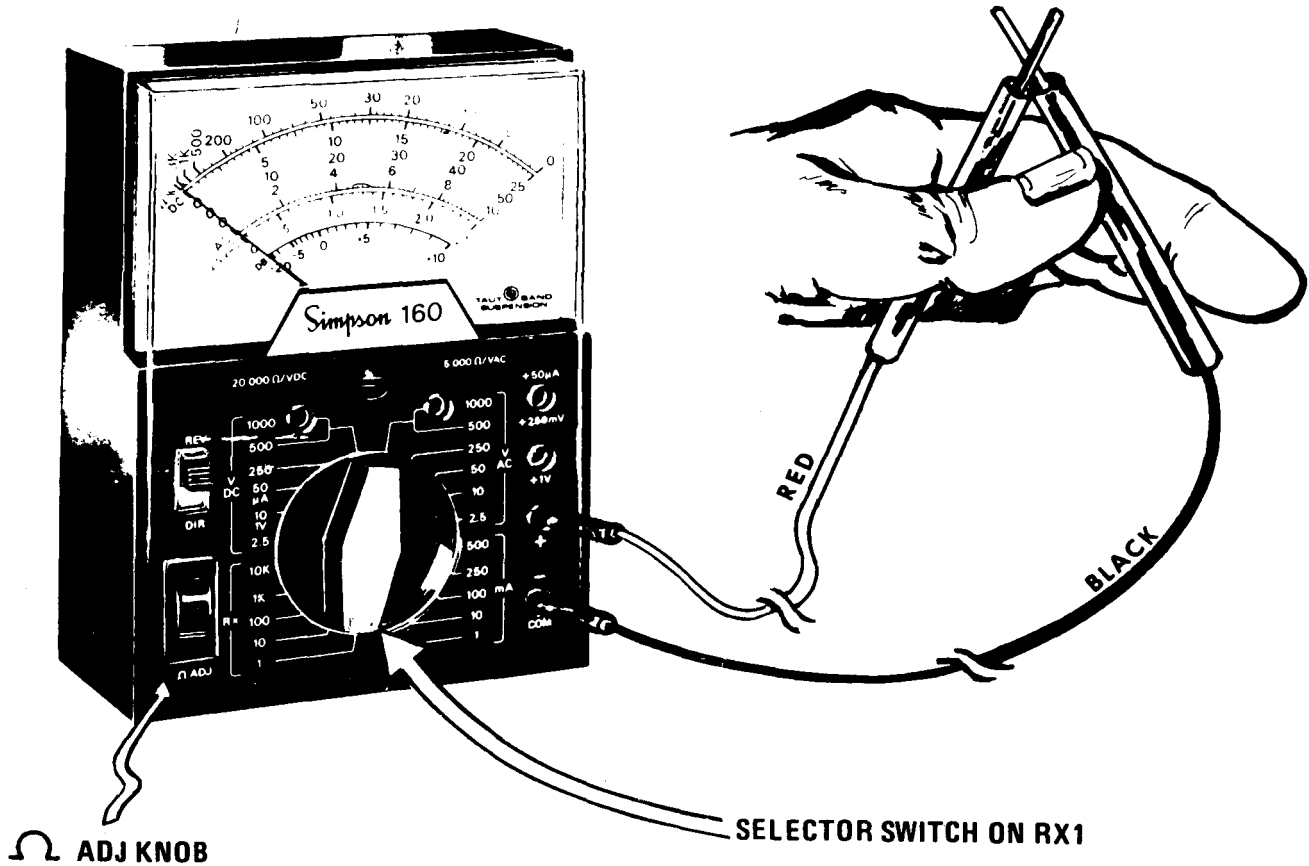

1. SET SELECTOR SWITCH ON "RX1".
2. PUT BLACK PROBE IN "COM-" JACK.
3. PUT RED PROBE IN "+" JACK.
4. WHILE TOUCHING THE PROBES TOGETHER, TURN "Ω ADJ" KNOB UNTIL NEEDLE IS OVER THE "0" ON THE TOP SCALE.

TS 022254

*Figure 4-9 "Zeroing" the multimeters.
(Sheet 3 of 3).*

NOTE
If the needle will not "zero", replace the batteries. If the needle still will not "zero" after replacing the batteries, turn the meter in for repair.

(2) **Continuity Tests.** Continuity tests are made to check for breaks in a circuit (such as the switch, light bulb, or electrical cable (fig. 4-10). To make a continuity check, do the following steps:

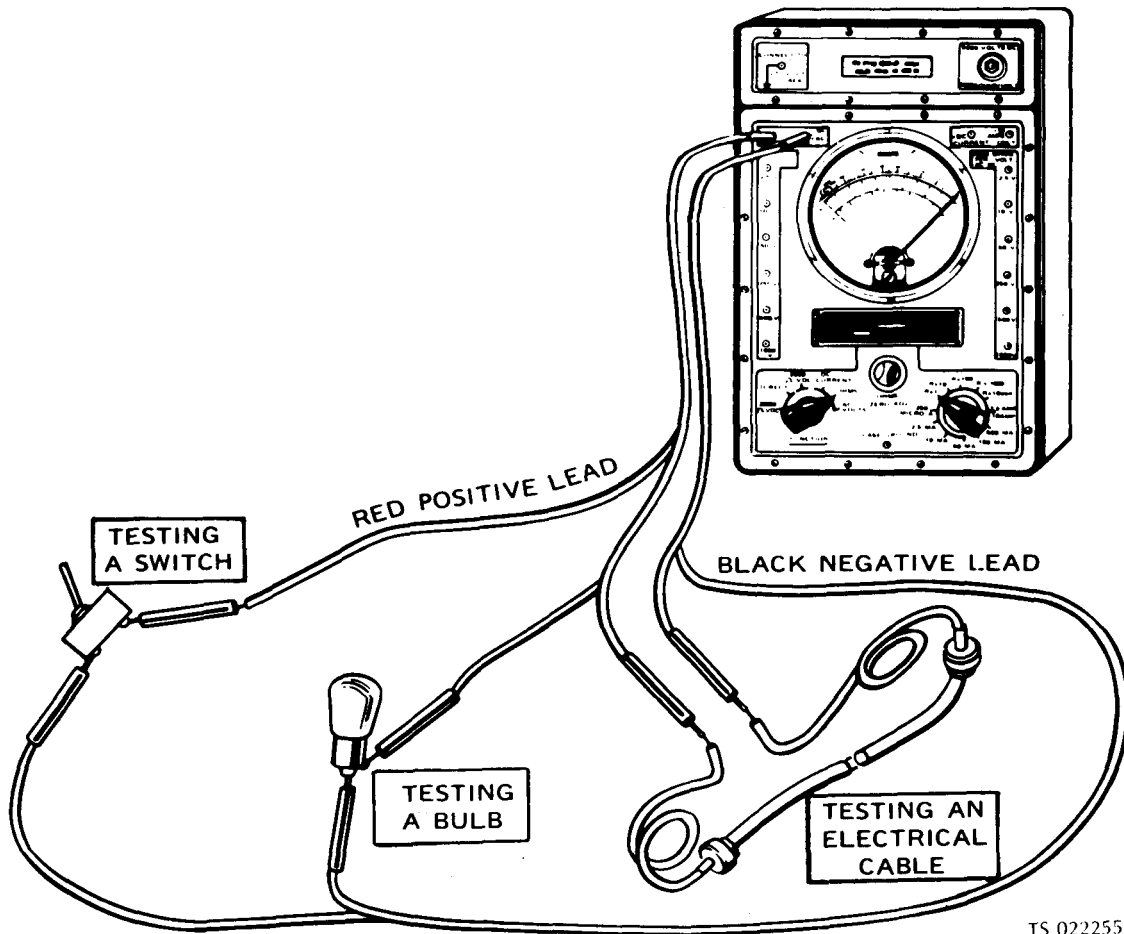

TS 022255

Figure 4-10. TS-352 continuity test.

- 9) (a) Set up and "zero" the multimeter (fig. 4-

CAUTION

Failure to do the following step can damage the multimeter.

(b) Disconnect the circuit being tested. To be safe, disconnect the battery ground strap.

(c) Connect the meter probes to both terminals of the circuit being tested. (The TS-352B/U is illustrated (fig. 4-10), but the probes are connected to the circuit the same way with all three multimeters.

(d) Look at the meter needle.

1. If the needle swings to the far right over the "O" on the top scale (on all three multimeters), the circuit has continuity.

2. If the needle doesn't move, the circuit is open (broken).

3. If the needle jumps or flickers there is a loose connection in the circuit being tested.

(3) **Testing for Shorts.** A short (or short circuit) occurs when two circuits that should not be connected have metal to metal contact with each other. A short also occurs when a circuit that should not touch the ground has metal to metal contact with ground. To check for shorts, do the following steps:

- (a) Set up and "zero" the multimeter (fig. 4-9).

CAUTION

Failure to do the following step can damage the multimeter.

(b) Disconnect the circuit being tested. To be safe, disconnect the battery ground strap.

(c) Using either type of multimeter, connect one probe to one circuit and the other probe to the other circuit or ground (if checking for a short to ground). The example (fig. 4-11) shows a check to see if wire "A" is shorted to wire "B" in the wiring harness.

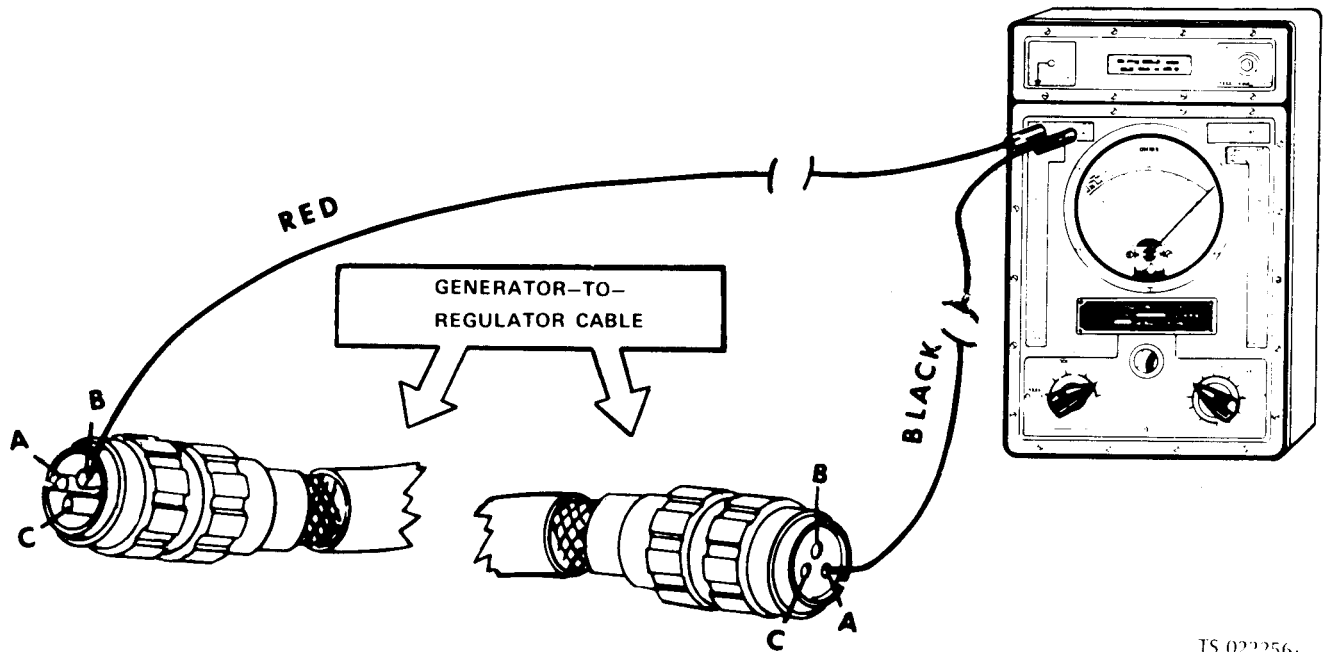

TS 022256,

Figure 4-11. Testing for shorts.

(d) Look at the needle.

1. If the needle swings to the far right over the "O" on the top scale, the circuits are shorted.

2. If the needle doesn't move, the circuits are not shorted.

3. If the needle jumps or flickers, the circuits are occasionally shorted.

(4) **Testing Resistance.** To measure resistance in a circuit, do the following steps:

(a) Set up and "zero" the multimeter (fig. 4-9).

CAUTION

Failure to do the following steps can damage the multimeter.

(b). Disconnect the circuit being tested. To be safe, disconnect the battery ground strap.

(c) If the test in this manual calls for an "ohms range" different than "RX1" or "X1", set the selector switch to that range (such as "RX10" or "X10").

NOTE

"Zero" the meter whenever you change ranges.

(d) Using either type of multimeter, connect the probes across the circuit or item to be measured. The example (fig. 4-12) shows measuring the resistance of a temperature sending unit.

(e) Read the meter (fig. 4-13). If the meter switch is on the "RX1" or "X1" range, the reading is taken directly from the top scale. If the meter switch is on a different range, multiply the reading on the scale according to the table below.

| Ohms Switch Setting | You Do |
|---------------------|-----------------------------|
| X1 or RX1 | Read number on scale. |
| X10 or RX10 | Multiply reading by 10. |
| X100 or RX100 | Multiply reading by 100. |
| X1K or RX1K | Multiply reading by 1,000. |
| X10K or RX10K | Multiply reading by 10,000. |

(Remember: K = 1,000)

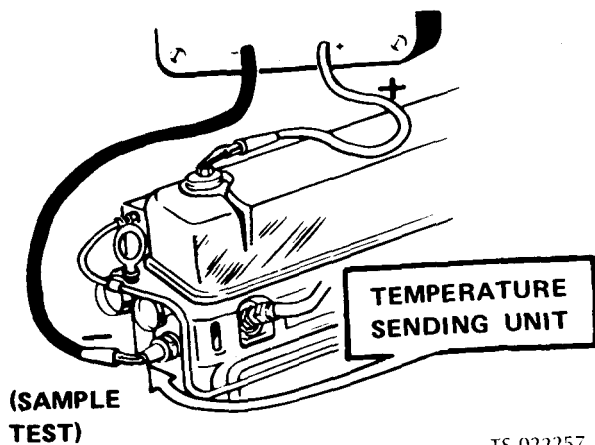
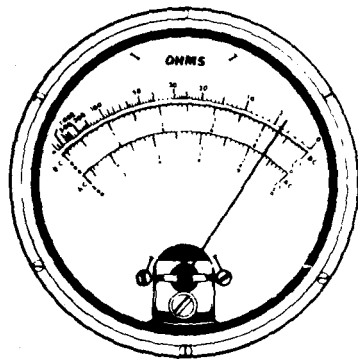
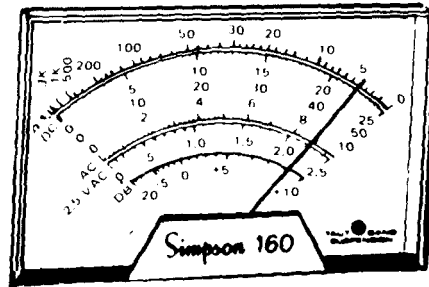

Figure 4-12. Testing resistance.



TS-352 B/U



SIMPSON 160

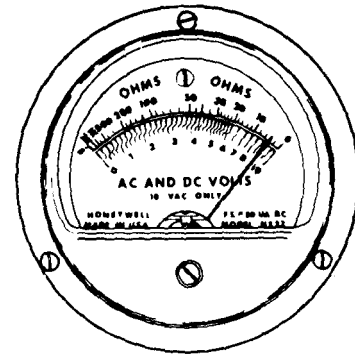

AN/URM-105

OHMS SWITCH SETTING

X1 OR RX1
 X10 OR RX10
 X100 OR RX100

READING

4 OHMS
 40 OHMS
 400 OHMS

TS 022258

Figure 4-13. Reading the ohm scale.

c. Using the DC Volts Scale (Figure 4-14). The DC scale is used to measure all voltage on

the equipment except the AC voltage.

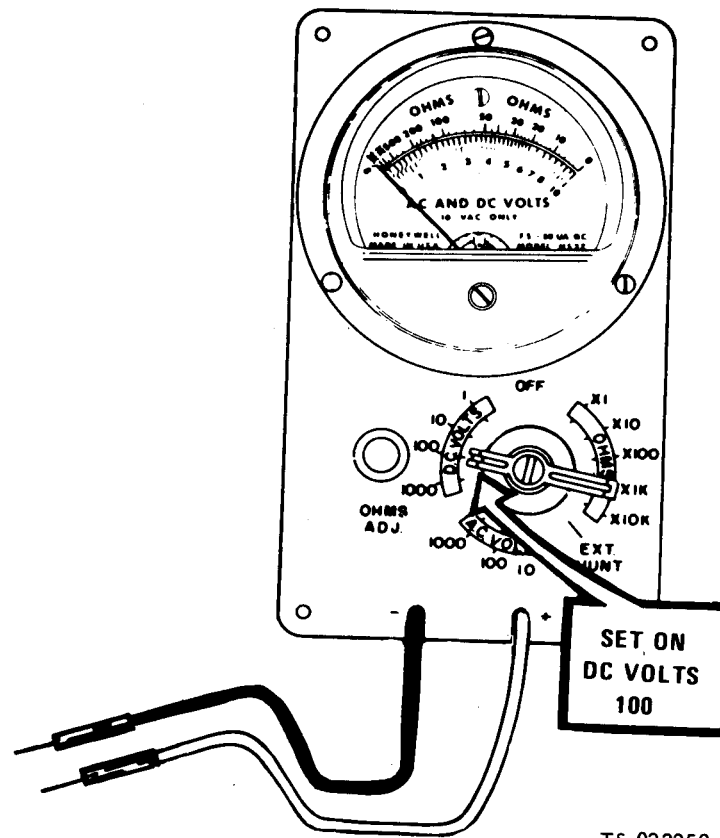
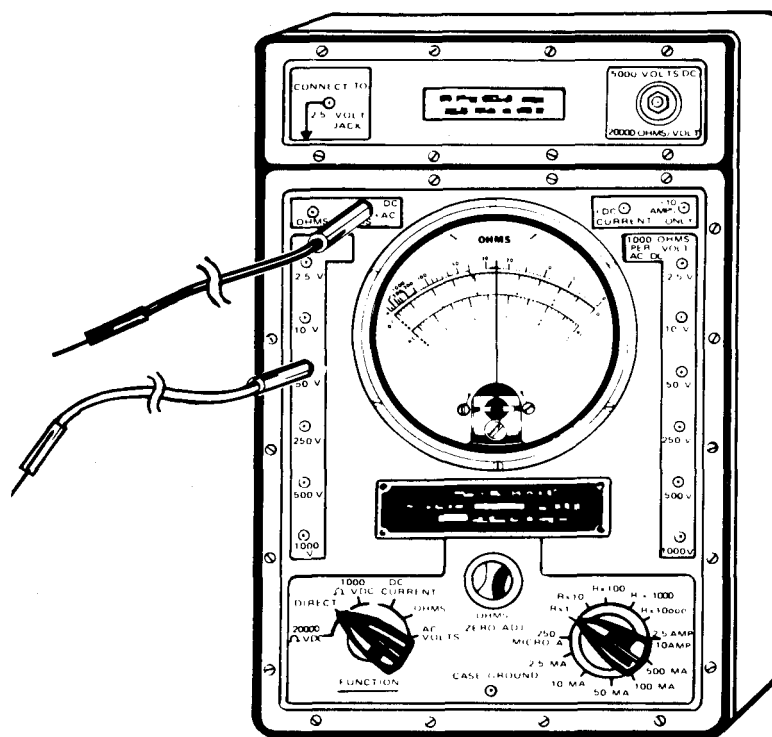
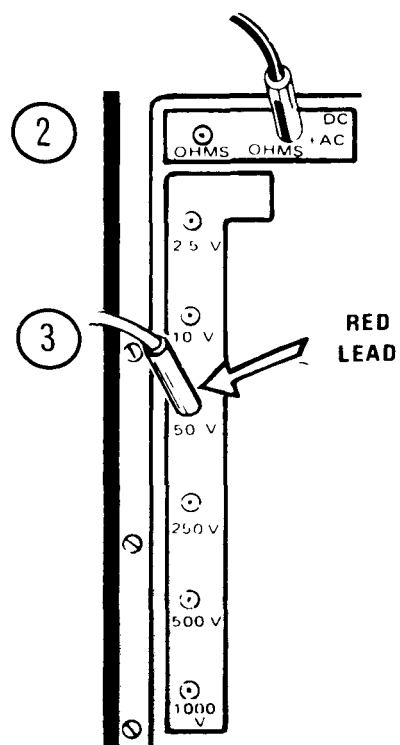
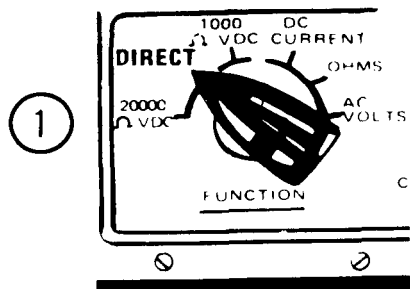

Figure 4-14. DC volts scale.
(Sheet 1 of 3).



A

B

TS 022260

Figure 4-14. DC volts scale.
(Sheet 2 of 3).

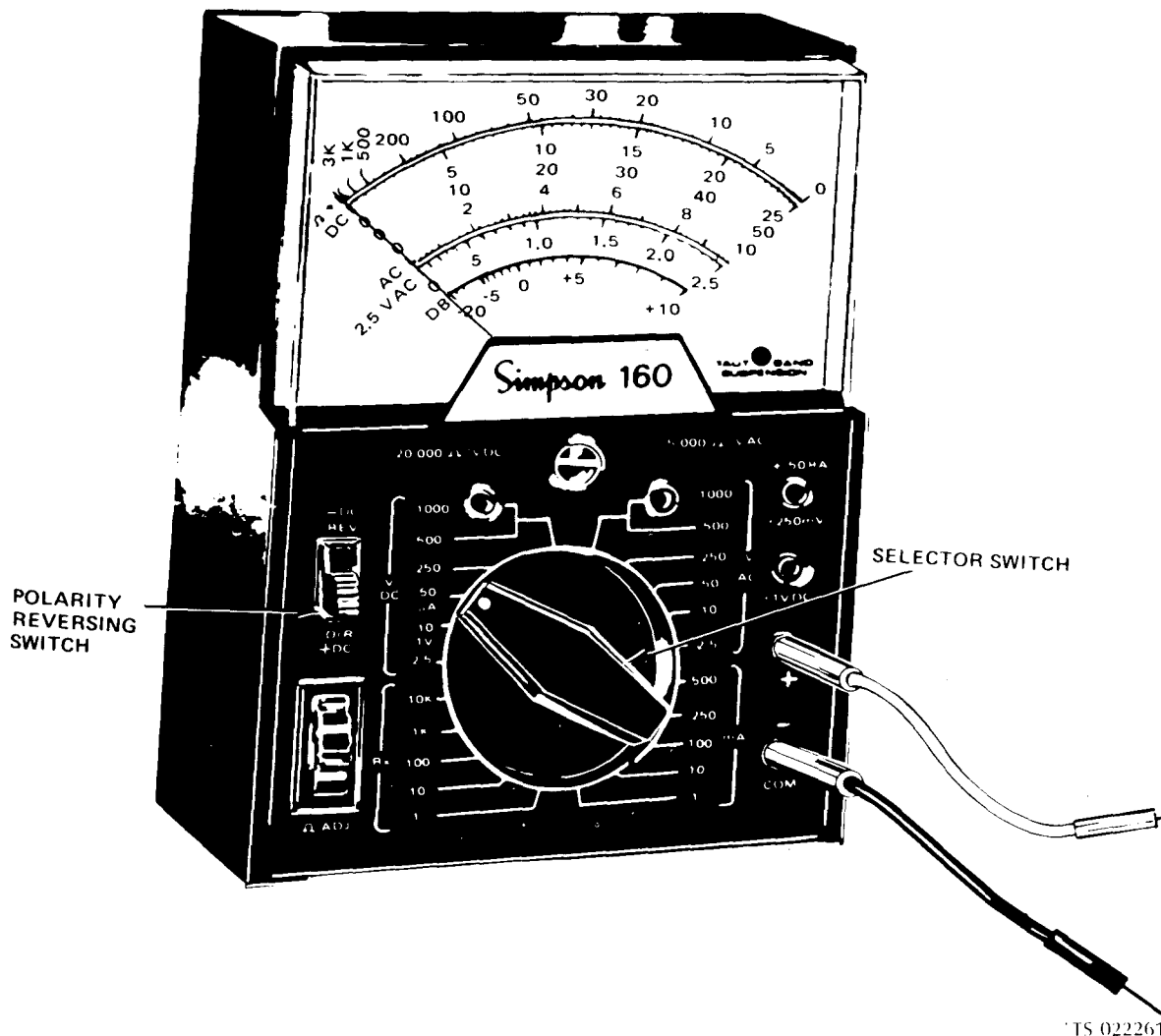

Figure 4-14. DC
(Sheet 3 of 3).

(1) Before using the multimeter to measure DC voltage, do the following steps that match the multimeter you have:

(a) **AN/URM-105.** Set meter switch to DC volts range given in TM. (To measure 24 volts DC, set switch on "100 DC VOLTS" range.)

(b) *TS-352B/U.*

1. Set FUNCTION switch to "DIRECT".
(Range switch can be at any position).

2. Put black lead in "-DC/+AC/OHMS" jack.

3. To measure 24 volts DC, plug red lead into "50V" jack on left side of meter. (If measuring less than 10 volts DC, use "10V" jack. If measuring less than 2.5 volts DC, use "2.5V" jack.)

(c) *Simpson 160.*

1. Connect black lead to "COM-" jack.

2. Connect red lead to "+" jack.

3. To measure 24 volts DC, set selector switch to "V/DC 50" position. (If measuring less than 10 volts DC, set selector switch to "V/DC 10"

position. If measuring less than 2.5 volts DC, set selector switch to "V/DC 2.5" position).

4. Set polarity reversing switch to the "+DC" position.

(2) To measure DC volts, do the following steps:

(a) Set up multimeter (paragraph (1) above).

NOTE

If you are unsure of the voltage to be measured on the equipment, always start on the highest range. This will protect the meter.

(b) Using either type of multimeter, connect the red probe to the positive (+) side of the circuit and the black probe to the negative (-) side. The example (fig. 4-15) shows 24 volts DC being measured across the batteries.

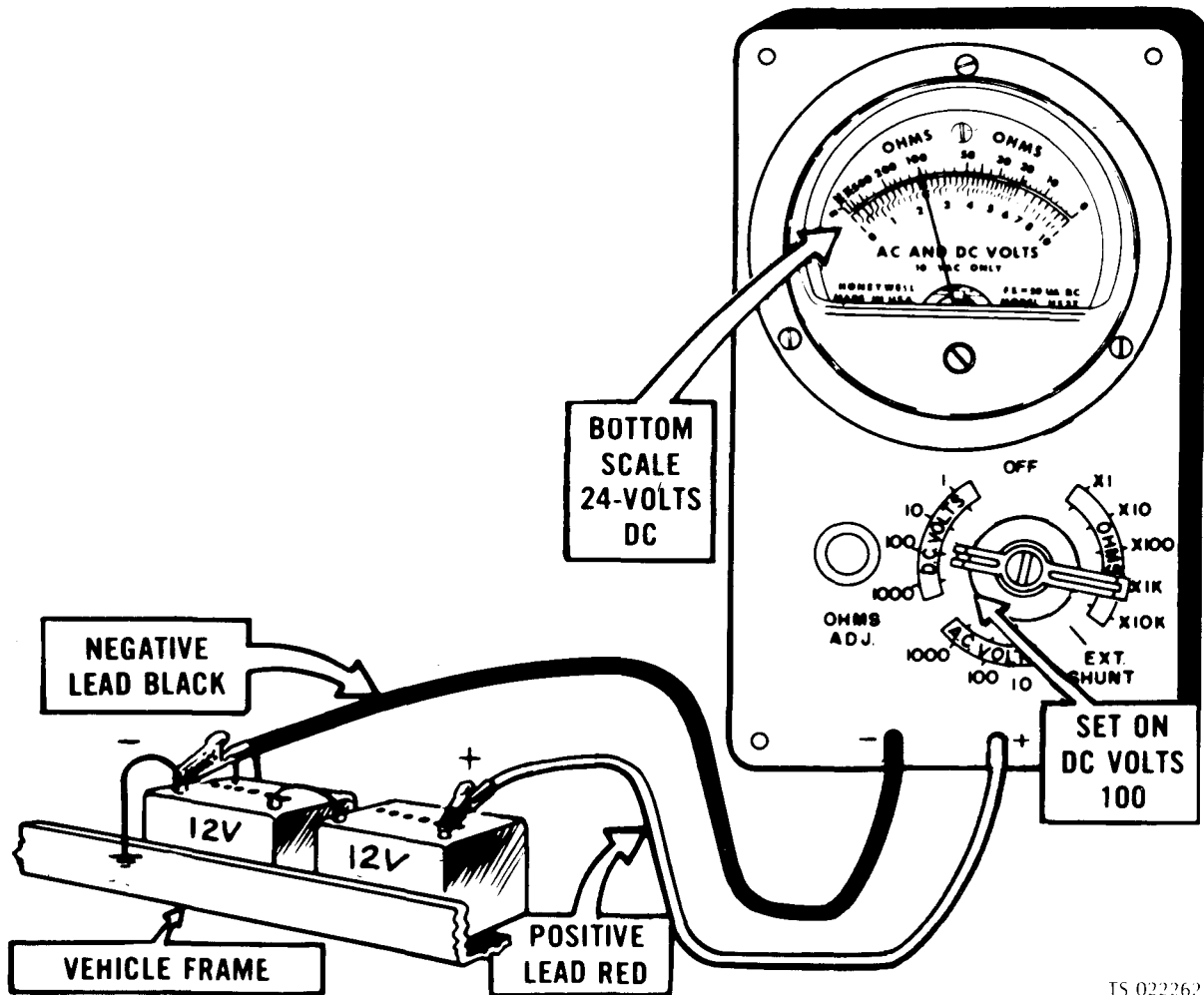

TS 022262

Figure 4-15. Measuring DC voltage.

(c) Read the meter. (The examples (fig. 4-16) shows how to read all three multimeters). If the needle tries to move off the scale to the left, reverse the probes on the circuit.

1. **Simpson 160.** Read the "DC" volts scale for the range the selector switch is set at.

| Switch Setting | Scale |
|----------------|-------------------------|
| V/DC 50 | 0-50 |
| V/DC 10 | 0-10 |
| V/DC 2.5 | 0-25 (and divide by 10) |

Thus, the meter (fig. 4-16) (1) is showing the following readings:

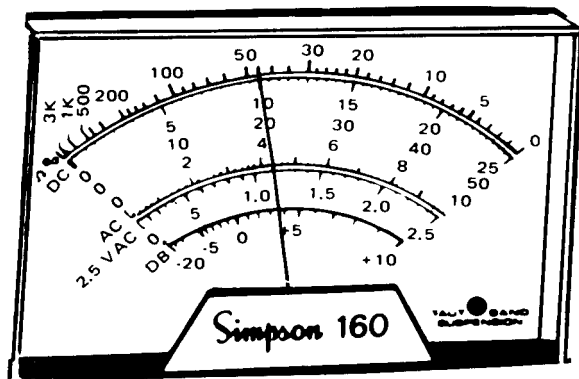

SWITCH SETTING

V/DC 50
V/DC 10
V/DC 2.5

READING

20 VOLTS DC
4 VOLTS DC
1 VOLT DC

Figure 4-16. Reading DC voltage.
(Sheet 1 of 3).

2. **TS-352B/U.** Read the "DC" volts scale for the range the red lead is plugged in at.

| Range | Scale |
|-------|--------------------------|
| 50V | 0-5 (and multiply by 10) |
| 10V | 0-10 |
| 2.5V | 0-2.5 |

Thus the meter (fig. 4-16) (2) is showing the following readings:

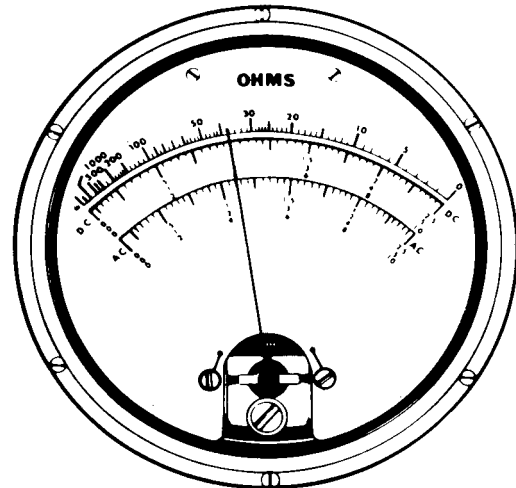

RANGE

50V
10V
2.5V

READING

20 VOLTS DC
4 VOLTS DC
1 VOLT DC

TS 022264

Figure 4-16. Reading DC voltage.
(Sheet 2 of 3).

straight-lined portion of the "AC and DC volts" scale for the range the selector switch is set at.

| Switch Setting | Scale |
|----------------|----------------------------|
| 1000 DC Volts | 0-10 (and multiply by 100) |
| 100 DC Volts | 0-10 (and multiply by 10) |
| 10 DC Volts | 0-10 (and divide by 10) |

Thus, the meter (fig. 4-16) (3) is showing the following readings:

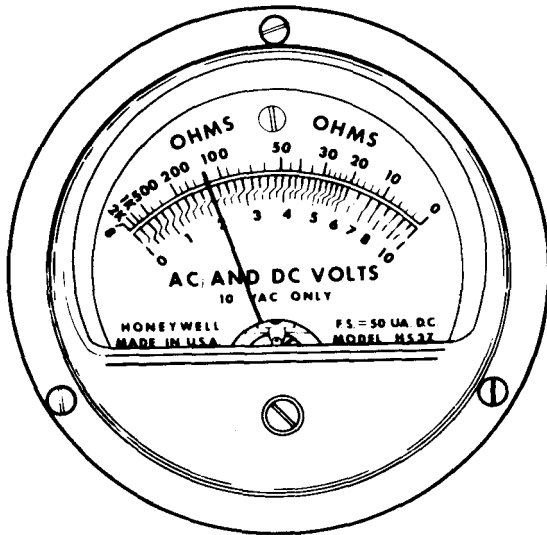

SWITCH SETTING
100 DC VOLTS
10 DC VOLTS
1 DC VOLT

READING
20 VOLTS DC
2 VOLTS DC
.2 VOLTS DC

FS 022265

Figure 4-16. Reading DC voltage.

(Sheet 3 of 3).

d. If the AC Volts Scale is Used. The AC volts scale is used to measure the AC voltage.

(1) Before using the multimeter to measure AC voltage, do the following steps that match the multimeter you have. Refer to figure 4-17.

(a) *AN/URM-105.* Set meter switch to "1000 AC volts".

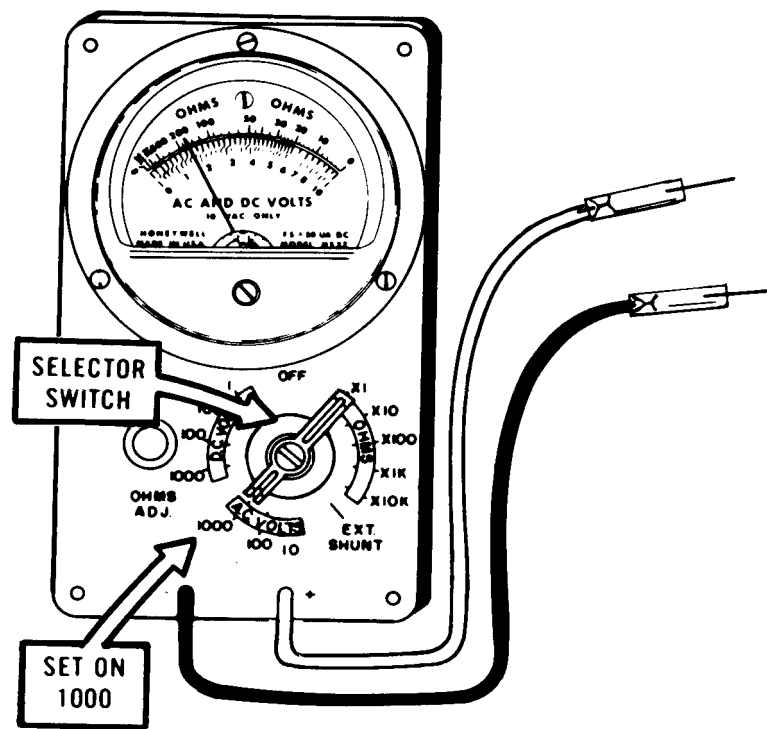

TS 022266

*Figure 4-17. AC volts scale.
(Sheet 1 of 3).*

(b) *TS-352B/U.*

1. Set "FUNCTION" switch to "AC volts". ("RANGE" switch can be at any setting.) (A, fig. 4-17) (Sheet 2 of 3).

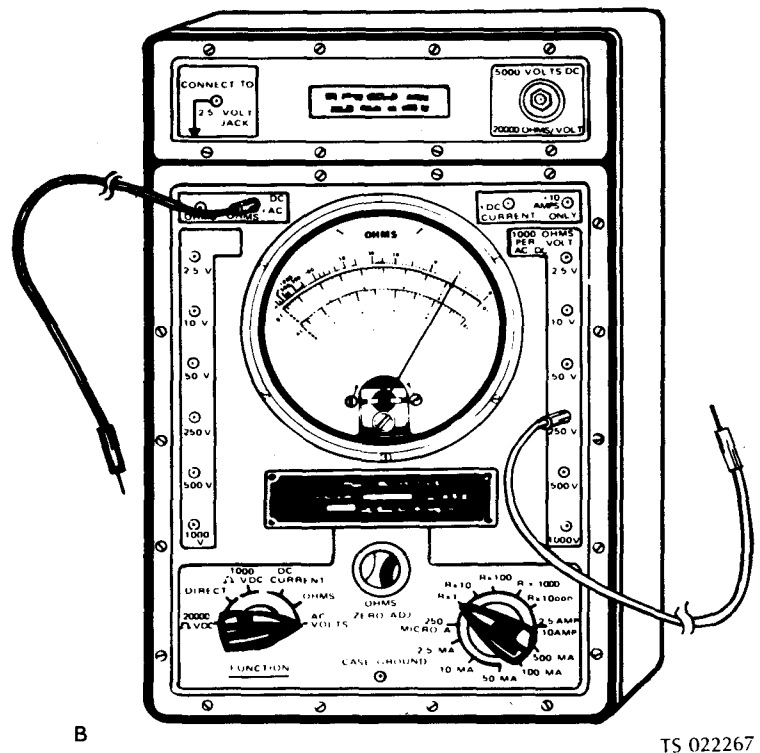
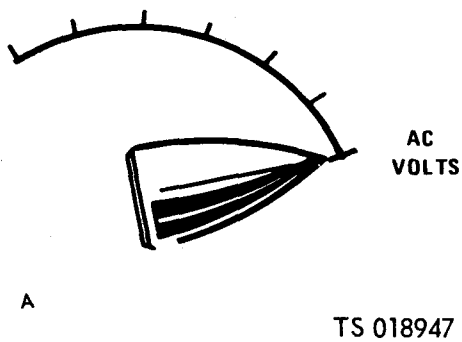

Figure 4-17. AC volt scale.

(Sheet 2 of 3).

2. Put black lead in "-DC/AC/OHMS" jack (B, fig. 4-17, sheet 2 of 3).

3. Put red lead in "250V" jack on right side of meter.

(c) *Simpson 160.*

1. Put black lead in "COM-" jack.

2. Put red lead in "+" jack.

3. Set selector switch to "V/AC 250" position.

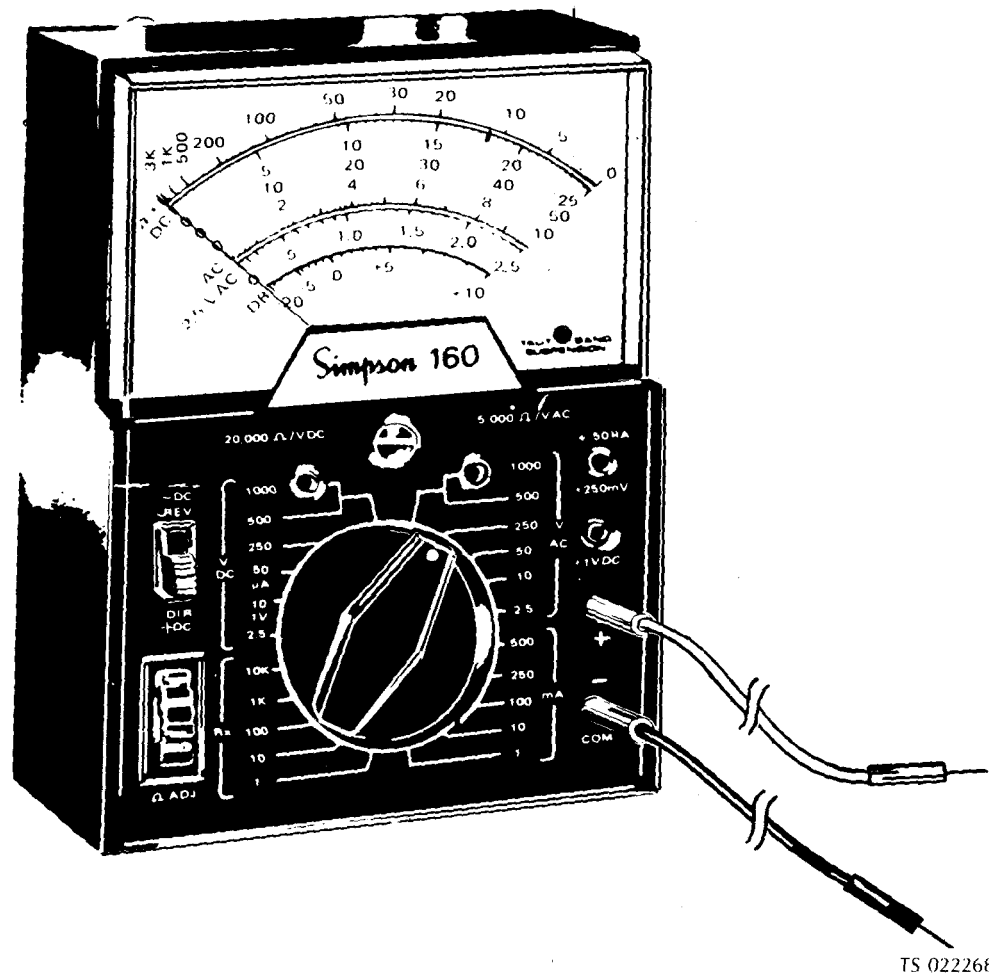

Figure 4-17. AC volt scale.

(Sheet 3 of 3).

(2) To measure AC voltage, do the following steps:

(a) Set up multimeter (fig. 4-17).

(b) Using either type of multimeter, connect one probe to one side of the circuit and the other probe to the other side. The example (fig. 4-18) shows AC voltage being measured across an AC light circuit.

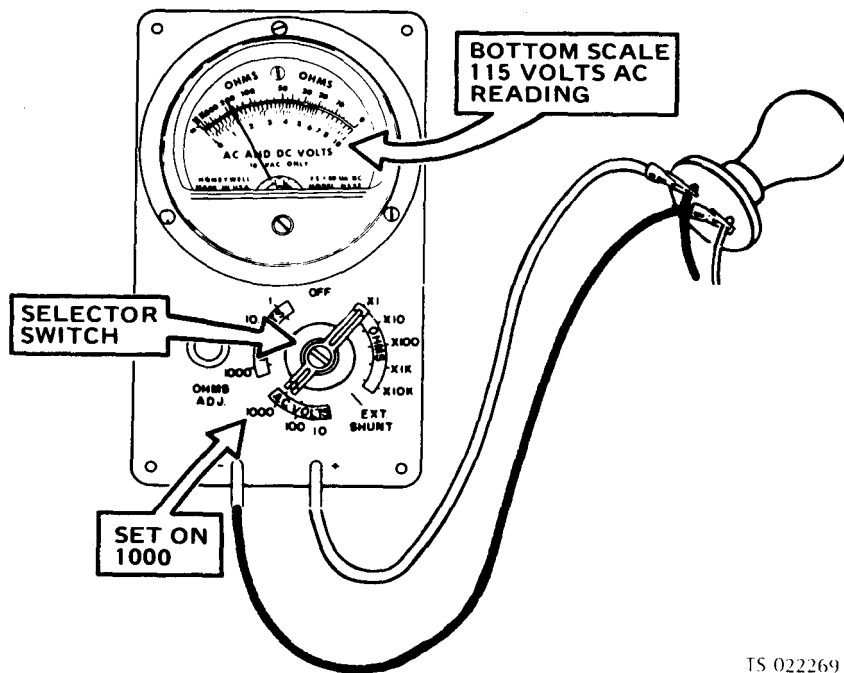

TS 022269

Figure 4-18. Measuring AC voltage.

(c) Read meter on the "AC" scale. Figure 4-19 shows a reading of 115 volts on all meters.

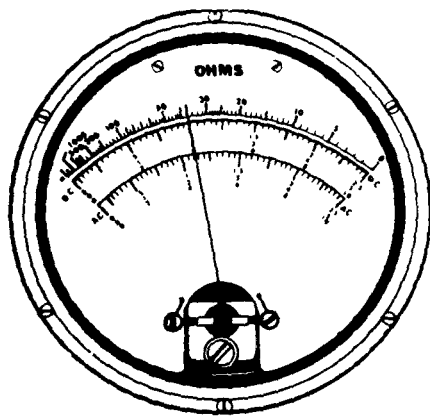

TS-352 B/U

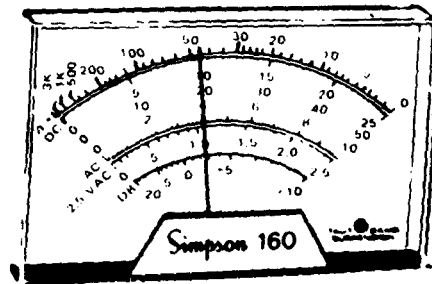

Simpson 160

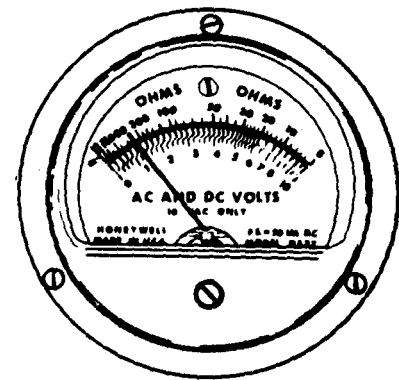

AN/URM-105

TS 022270

Figure 4-19. Reading AC voltage.

Table 4-3. Organizational Troubleshooting

| MALFUNCTION | TEST OR INSPECTION | CORRECTIVE ACTION |
|-------------|--------------------|-------------------|
|-------------|--------------------|-------------------|

1. STARTER CRANKS ENGINE BUT STOPS WHEN START SWITCH IS RELEASED

Step 1. Test for defective K1 relay. Refer to paragraph 4-42c for test procedures.
Replace defective relay. Refer to paragraph 4-42 for removal and installation instructions.

Step 2. Check for defective oil pressure indicator.
If indicator is defective, refer to paragraph 4-26 for removal and installation instructions.

2. GENERATOR FAILS TO SUPPLY POWER TO LOAD

Check for a broken, burned, or cracked circuit breaker. Check for broken and worn wiring. Also, test the circuit breaker with a multimeter.

If circuit breaker is damaged or defective, refer to paragraph 4-41 for removal and installation instructions.

NOTE

To facilitate installation of the circuit breaker, before removal of the wire leads from the terminal at the back of the unit, make a diagram that shows the exact position of each lead. It will be found that if the leads are allowed to turn from their original position they will be too short to enable the successful installation of the circuit breaker.

3. FREQUENCY METER FAILS TO SHOW FREQUENCY

Check for loose connections or broken wiring.
Refer to paragraph 4-39 for repair instructions.

4. VOLTMETER FAILS TO SHOW VOLTAGE

Step 1. See malfunction 3, above. If that does not correct the problem, go on to step 2.

Step 2. Check for a broken or cracked voltmeter. Inspect wiring for breaks and wear. Test voltmeter by connecting an additional voltmeter to load terminals of generator set and taking comparative readings to establish validity of generator set voltmeter.
If voltmeter is defective, refer to paragraph 4-33 for removal and installation instructions.

Step 3. Check for a broken or cracked voltage selector switch. Inspect wiring for breaks and wear. Test with a multimeter for continuity of switch contacts.
If voltage selector switch is damaged or defective, refer to paragraph 4-37 for removal and installation instructions.

Table 4-3. Organizational Troubleshooting

| MALFUNCTION | TEST OR INSPECTION | CORRECTIVE ACTION |
|--------------------|---------------------------|--------------------------|
|--------------------|---------------------------|--------------------------|

5. GENERATOR FAILS TO BUILD UP RATED VOLTAGE

- Step 1.** Check for loose, cut, broken, and worn wiring.
If connections are loose, tighten them. If wiring is damaged, repair it. Refer to paragraph 4-39 for repair instructions.
- Step 2.** Check for a broken or cracked voltage selector switch.
Check for damaged wiring.
If the voltage selector switch is damaged or defective, refer to paragraph 4-37 for removal and installation instructions.
- Step 3.** Inspect the variable resistor for cracks, corrosion, loose connections and other damage. Test the variable resistor as follows:
- a. Stop the generator set and disconnect terminal 26 of the voltage regulator terminal board.
 - b. With a multimeter, check resistance across the variable resistor terminals by varying the resistor from full counterclockwise to full clockwise position. This reading should move smoothly from 0 to 750 ohms \pm 10% as the variable resistor is rotated to the full clockwise position.

NOTE

On sets manufactured prior to 1968, this reading will be 0 to 250 ohms \pm 10%.

Replace the variable resistor (para 4-16) if the reading is not within specifications.

- Step 4.** Check the voltage regulator for loose wires, corrosion, metal to metal contact, or incorrect wiring.

6. VOLTMETER READING TOO HIGH OR TOO LOW

- Step 1.** Check for a broken or cracked voltage adjusting rheostat switch. Inspect for broken wiring or loose connections around the switch.
If voltage adjusting rheostat switch is damaged or defective, refer to paragraph 4-38 for removal and installation instructions.
- Step 2.** Check for broken or cracked voltmeter. Inspect for broken wiring or loose connections. Test voltmeter by connecting an additional voltmeter to load terminals of generator set and taking comparative readings to establish validity of generator set voltmeter.
If voltmeter is damaged or defective, refer to paragraph 4-33 for removal and installation instructions.

7. NO POWER AVAILABLE AT OUTLET RECEPTACLE (MODEL MEP-017A)

- Step 1.** Check for loose connections by visually observing or by grasping wires and tugging slightly. Also, check for broken or worn wiring.
If damage or loose connections are found, refer to paragraph 4-39 for repair instructions. If there are no loose connections or damaged wiring, go on to step 2.
- Step 2.** Check for cracked or broken outlet receptacle.
If receptacle is damaged, refer to paragraph 4-43 for removal and installation instructions.

Table 4-3. Organizational Troubleshooting

| MALFUNCTION |
|---------------------------|
| TEST OR INSPECTION |
| CORRECTIVE ACTION |

8. GENERATOR OVERHEATS

Check the engine shrouds and cooling fins by observation.
See if there is a blockage or obstruction.
If air passages are obstructed, clean them.

9. GENERATOR SET NOISY

Check the mounts by moving slightly.
If mounts are loose or cracked, refer to paragraph 4-44 for removal and installation instructions.

10. PANEL LIGHTS FAIL TO OPERATE

- Step 1.** Check for loose connections. Inspect for worn or broken wiring.
Refer to paragraph 4-39 for repair instructions.
- Step 2.** Check for a broken or cracked panel light switch. Check for worn or broken wiring.
Refer to paragraph 4-31 for removal and installation instructions.

11. TIME TOTALIZING METER FAILS TO OPERATE OR IS INACCURATE

- Step 1.** Check for loose connections and broken or worn wiring.
Refer to paragraph 4-39 for repair instructions.
- Step 2.** Check for a broken or cracked time totalizing meter.
Check for loose or broken wiring.
Refer to paragraph 4-25 for removal and installation instructions.

12. BATTERY CHARGING AMMETER GIVES NO READING OR GIVES INACCURATE READING

- Step 1.** Check for loose connections at the wiring by observing or slightly moving the harness. Also check for broken or worn wiring.
Refer to paragraph 4-39 for repair instructions.
- Step 2.** Check for cracked or broken battery charging ammeter. Test ammeter leads with a multimeter, for continuity.
Refer to paragraph 4-29 for removal and installation instructions.

13. OIL PRESSURE INDICATOR FAILS TO INDICATE OR GIVES LOW READING

- Step 1.** Check for loose connections by observing visually or move harness slightly to indicate loose connecting points.
Check all wiring to see if it is worn or broken,
Refer to paragraph 4-39 for repair instructions.
- Step 2.** Check indicator for cracked or broken glass, bent needle, or damaged wiring.
Refer to paragraph 4-26 for removal and installation instructions.
- Step 3.** Check for proper operation of relay K2 and K4.
Refer to paragraph 4-42 for removal and installation instructions.

Section VII. RADIO INTERFERENCE SUPPRESSION

4-17. General Methods Used to Attain Proper Suppression.

Essentially, suppression is attained by providing a low resistance path to ground for stray currents. The methods used include shielding the ignition and high frequency wires, grounding the frame with bonding straps, and using capacitors and resistors. For general information on radio suppression, refer to TM 11-483.

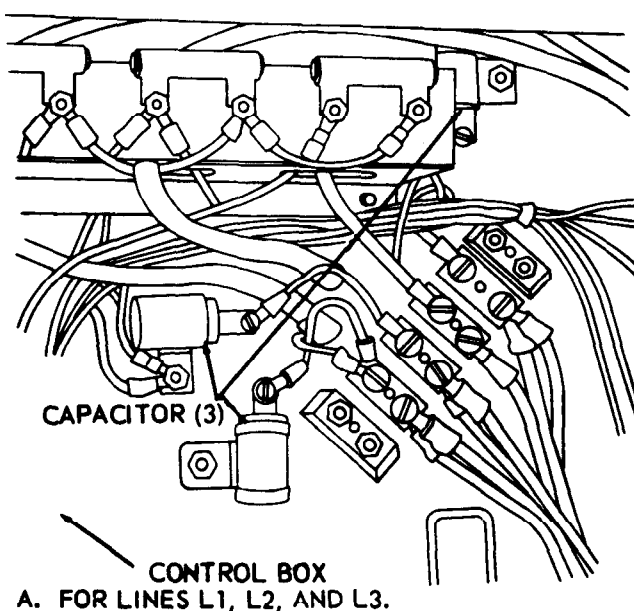

4-18. Interference Suppression Components.

The generator set is provided with four capacitors as primary radio interference suppression components. These are connected to each of the three generator phases and to the neutral line. The capacitors are each rated at 0.1 uf, 500 vac. They are shown in figure 4-20.

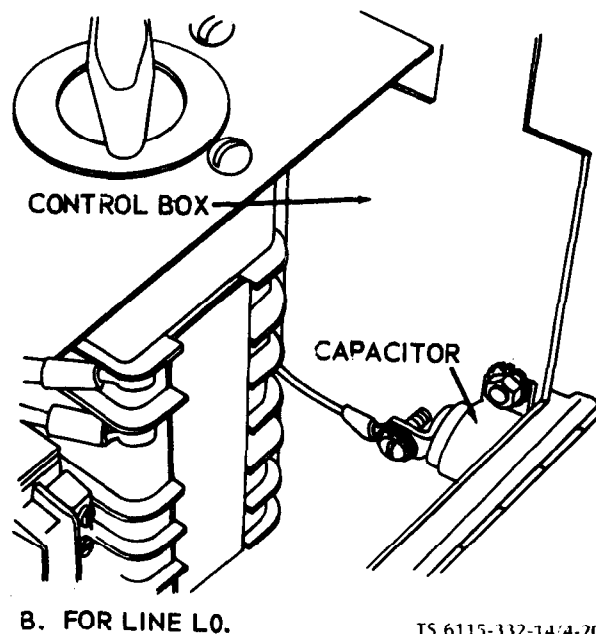

TS 6115-332-14/4-20

Figure 4-20. Replacement of radio interference suppression components.

4-19. Replacement of Suppression Components.

a. Removal. For replacement of radio interference suppression components, refer to figure 4-20 and the following instructions to remove the capacitors.

- (1) Tag and disconnect electrical leads from the capacitor.
- (2) Remove the nuts, washers, and screws securing the capacitor to the control box,
- (3) Remove the capacitor.
- (4) Remove the remaining capacitors in a similar manner.

b. Cleaning, Inspection and Repair.

- (1) Clean the capacitors using a clean lint free cloth,
- (2) Inspect capacitors for corroded terminals, cracked case or for evidence of overheating.
- (3) Replace damaged or defective capacitors as required,

c. Installation

- (1) Position capacitor in place in control box and secure with screws, waahera, and nuts.
- (2) Reconnect leads,
- (3) Install remaining capacitors in the same manner.

4-20. Testing of Radio Interference Suppression Components.

Test the capacitors for leaks, shorts, and open circuits, using a capacitor tester.

Replace capacitors that fail to give a reading within 10 percent of the value in microfarads given in paragraph 4-18.

Section VIII. MAINTENANCE OF THE ENGINE ELECTRICAL SYSTEM

4-21. General

This section covers maintenance instructions for the battery and battery and battery cables, and slave receptacle, switches, panel lights and meters. Unless otherwise specified, these instructions apply to both the model MEP-017A and model MEP-022A generator sets. For electrical system maintenance that applies to the engine, refer to TM 5-2805-258-14.

4-22. Battery Cables, Starter Cable and Grommet, Terminal Stud, and Terminal Cover

a. Removal.

(1) Refer to figure 3-4 and remove the fuel can as follows:

(a) Lift locking handle and remove the fuel can adapter from the fuel can.

(b) Lift clamp to loosen strap securing the fuel can in fuel can bracket.

(c) Remove strap from fuel can and remove fuel can from bracket.

(2) Refer to figure 4-21 and the following instructions to remove the terminal cover, battery cables, starter cable and grommet, and terminal stud.

(a) Remove terminal cover, loosen nut securing the negative battery cable to the battery terminal and disconnect battery cable.

(b) Remove nuts, lockwashers, and screws securing the other end of the negative battery cable to the skid and remove negative cable.

(c) Disconnect starter cable at starter and remove grommet from engine shroud.

(d) Remove nut and lockwasher securing the starter cable to the terminal stud and disconnect cable.

NOTE

Exercise care when removing starter cable to prevent possible damage when withdrawing cable from the engine shroud.

(e) Remove starter cable.

(f) Loosen nut securing positive cable to the battery terminal and disconnect the positive battery cable.

(g) Remove the nut, lockwasher, insulating washers, and terminal stud securing other end of battery cable to the skid base and remove cable.

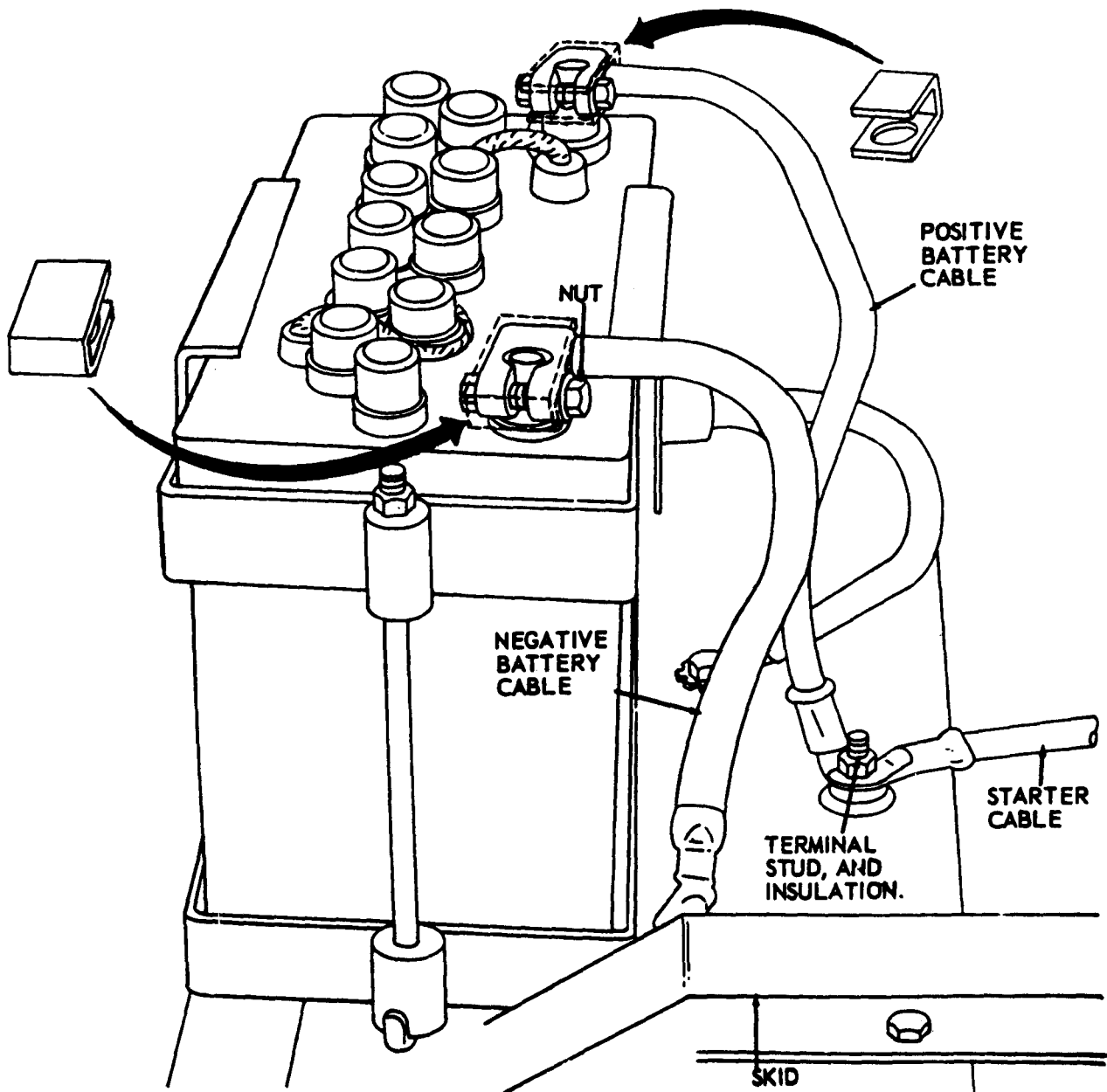

TS 6115-112-14-4-21

Figure 4-21. Battery cables, starter cable and grommet, and terminal stud, removal and installation.

b. *Cleaning, Inspection and Repair.*

WARNING

Clean all parts in a well-ventilated area. Avoid inhalation of solvent fumes and prolonged exposure of skin thoroughly. Dry cleaning solvent (Fed. Spec. P-D-680 Type II) used to clean parts is potentially dangerous to personnel and property. Do not use near open flame or excessive heat. Flash point of solvent is 140°F (60°C).

- (1) Clean items with cleaning solvent, Fed. Spec. P-D-680 or Type II, and dry thoroughly.
- (2) Inspect the cables for cracked, frayed, or missing sections of insulation.
- (3) Inspect for corroded, burned, or damaged cable ends.
- (4) Inspect the terminal stud for signs of burned areas or stripped threads.
- (5) Inspect the grommet for cracks.
- (6) Replace all defective parts.

WARNING

Make sure that battery terminal covers are installed on both battery terminals before installing cables.

c. *Installation*

- (1) Position terminal stud in place on skid base and install insulating washers on stud.
- (2) Secure one end of positive battery cable to terminal stud with lockwasher and nut.
- (3) Place battery terminal cover over positive battery terminal. Place other end of positive cable over positive terminal on battery and secure by tightening nut.
- (4) Install rubber grommet in engine shroud.
- (5) Thread starter cable thru grommet.
- (6) Secure starter cable to terminal stud with lockwasher and nut.
- (7) Secure other end of starter cable to the engine starter.
- (8) Secure end of negative battery cable to skid base with screws, lockwashers, and nuts.
- (9) Place battery terminal cover over negative battery terminal. Place other end of negative cable over negative terminal on battery and secure by tightening nut.
- (10) Place fuel can in bracket and install fuel can strap.
- (11) Secure by depressing clamp.
- (12) Install fuel can adapter in fuel can and lock by depressing locking handle.

4-22.1 Relays and Resistors (Model MEP017A)

Relays K1, K2, K3, and K4 furnish starting, stopping, safety, and operational control for the generator. The relays are mounted on printed circuit board TB3.

(1) Relay K1 is used to start the generator engine by energizing the starter solenoid through the normally closed contacts of relay K3.

(2) Relay K2 is used to stop the engine. The relay is energized by the S1 stop switch and S5 remote-local switch. When relay K2 is energized, relay K3 and K4 are de-energized, thereby removing the battery charger from the circuit and grounding the magneto through the normally closed contacts or relay K4.

(3) Relay K3 is energized by the battery charger rectifier through the normally closed contacts of K4, and de-energized by low oil pressure.

(4) Relay K4 is energized through the normally closed contacts of relay K2 and the silicon diode, CR1. This occurs when start and stop switch, S1 is activated.

4-23. Battery and Battery Frame.

a. *Testing*

WARNING

- Do not smoke or use an open flame near batteries. Batteries generate an explosive gas.
- Electrolyte contains sulfuric acid and can cause severe burns. Handle it with care. If the solution comes in contact with the body or clothing, rinse immediately with clean water.

The 6TN and 6TL batteries can be mixed or matched. However, maintenance-free batteries cannot be mixed or matched with military batteries. The 6TN and or the 6TL batteries will perform properly in hot weather as long as electrolyte levels are carefully monitored. If the electrolyte expands and causes the level to rise, some fluid must be removed. If the level becomes too low due to evaporation, distilled water may be used to obtain the proper level. A good grade of drinking water (excluding mineral waters) may be used if distilled water is not available.

Electrolyte (NSNs 6810-00-249-9354 and 6810-00-843-1640) have a specific gravity of 1.280 and should be used in these batteries. Do NOT adjust the electrolyte in wet batteries to a lower specific gravity.

(1) The battery should be tested with a hydrometer and kept to a specific gravity of 1.250 or above.

NOTE

Before testing the battery remove the terminal cover.

(2) Always test a battery for degree of charge before adding water. The specific gravity between

the cells should be within .025. A dangerously low point of charge indicated by a hydrometer reading of 1.150 or less will permit the battery to freeze at temperatures only a few degrees below the freezing point of water. A specific gravity 1.250 will permit the battery to withstand temperatures as low as -65°F without freezing.

(3) The electrolyte level should be maintained $\frac{3}{8}$ inch (0.95 cm) above the separators or insulators by addition of distilled water or "approved water"

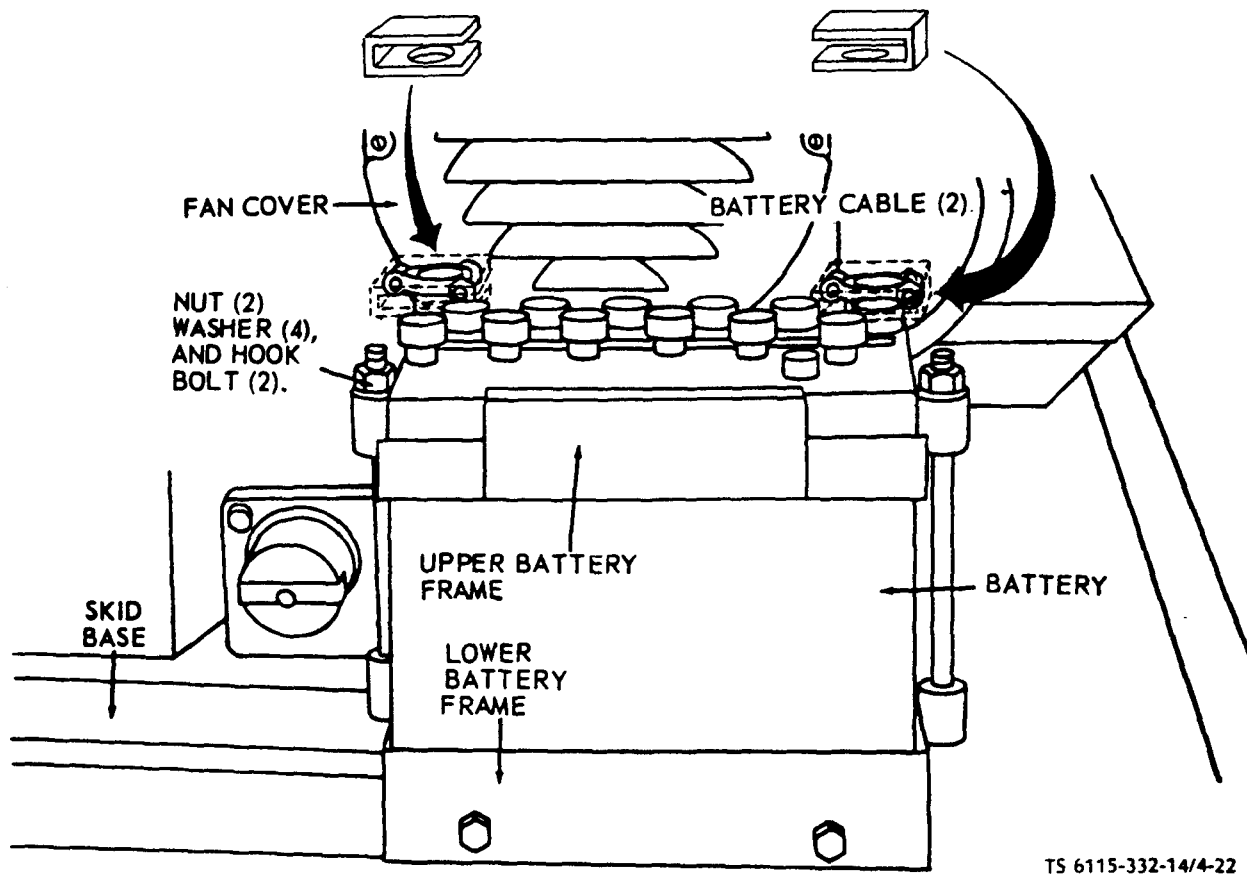

Figure 4-22. Battery and battery frame, removal and installation.

(water free from impurities by analysis). Do not overfill the cells of the battery as either has a detrimental effect on battery life.

(4) Use of a mirror is recommended when checking electrolyte level in batteries. The charging rate is correct when the battery maintains a minimum specific gravity of 1.250 and does not require the addition of more than 1 ounce (28 grams) of water per cell per week or 50 service hours.

b. Removal. Refer to figure 4-22 and the following instructions to remove the battery and battery frame.

(1) Remove terminal cover, disconnect battery cables.

(2) Remove nuts and washers which secure the upper battery frame to the hook bolts.

(3) Remove upper battery frame and hook bolts.

(4) Lift battery from frame.

(5) Remove nuts, lockwashers, and screws which secure the lower battery frame to the skid and remove frame.

c. Cleaning, Inspection and Repair.

(1) Brush all corrosion from battery and battery frame.

WARNING

Clean all parts in a well-ventilated area. Avoid inhalation of solvent fumes and prolonged exposure of skin to cleaning solvent. Wash exposed skin thoroughly. Dry cleaning solvent (Fed. Spec. P-D-680 Type II) used to clean parts is potentially dangerous to personnel and property. Do not use near open flame or excessive heat. Flash point of solvent is 140°F (60°C).

(2) Clean the frame and hardware items with cleaning solvent, Fed. Spec. P-D-680 Type II, and dry thoroughly.

(3) Inspect the battery frame for cracks, broken welds, distortion, and excessively corroded areas.

(4) Inspect the hook bolts for damaged threads and other defects.

d. Installation.

(1) Position lower battery frame in place on skid and secure with screws, lockwashers and nut.

(2) Position battery in place in battery frame.

(3) Position hook bolts in place.

(4) Place upper battery frame over hook bolts and secure with washers and nuts.

(5) Install battery terminal covers on both battery terminals. Reconnect battery cables.

4-24. Slave Receptacle and Bracket.

a. Removal. Refer to figure 4-23 and the following instructions to remove the slave receptacle and bracket.

(2) Remove nuts, lockwashers, and screws securing the slave receptacle to the mounting bracket and remove the slave receptacle.

(3) Remove nuts, lockwashers, and screws securing the slave receptacle mounting bracket to the skid base and remove the mounting bracket.

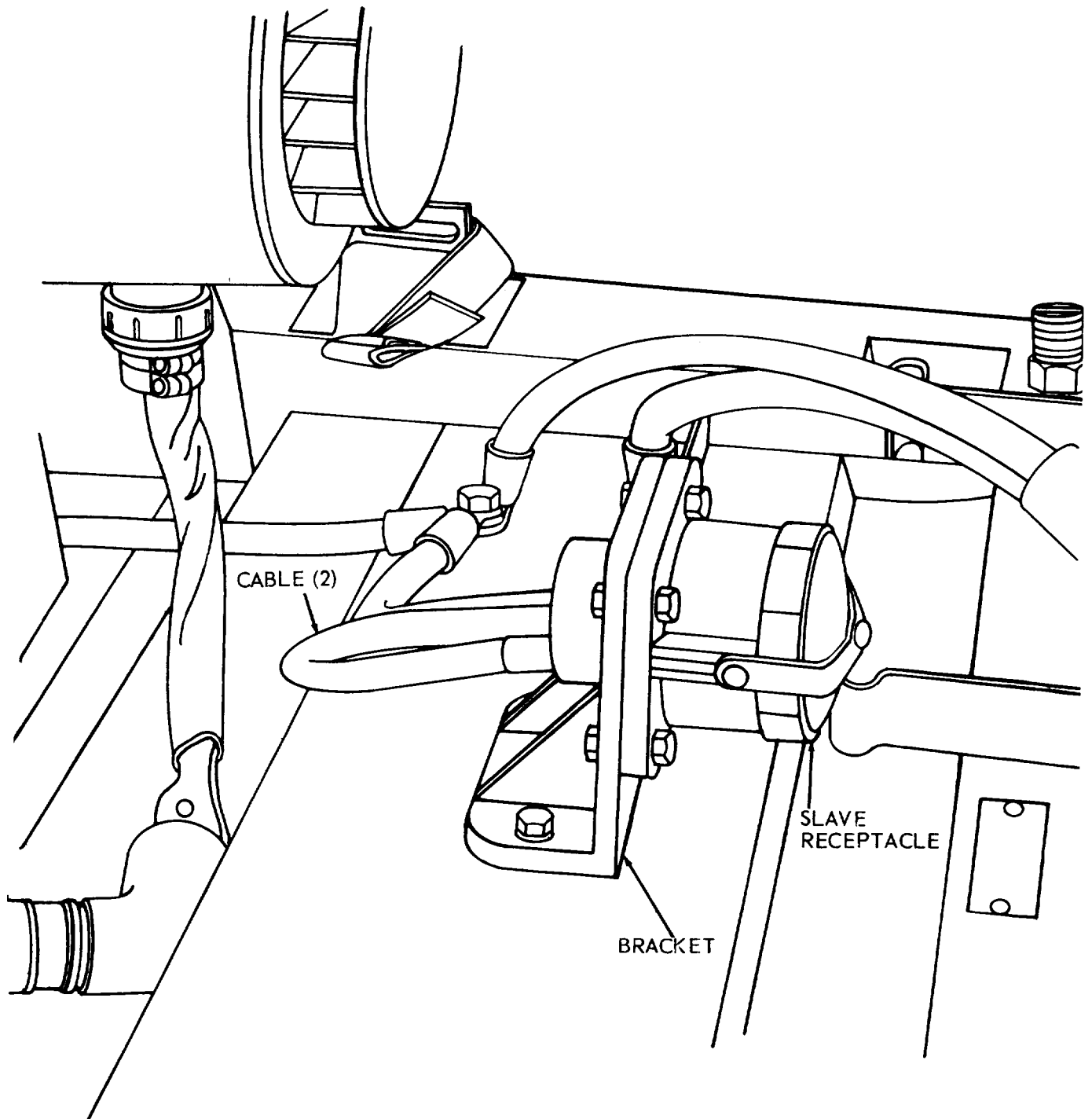

TS 6115-332-14/4-23

Figure 4-23. Slave receptacle and bracket, removal and installation.

b. Cleaning, Inspection and Repair.

WARNING

Clean all parts in a well-ventilated area. Avoid inhalation of solvent fumes and prolonged exposure of skin to cleaning solvent. Wash exposed skin thoroughly.

- Dry cleaning solvent (Fed. Spec. P-D-680, Type II) used to clean parts is potentially dangerous to personnel and property. Do not use near open flame or excessive heat.
 - Flash point of solvent is 140° (60°C).
- (1) Clean metal items with cleaning solvent, Fed. Spec. P-D-680 Type II, and dry thoroughly.
 - (2) Inspect the bracket for cracks.
 - (3) Inspect the slave receptacle for worn insulation on the cables, cracks, burned contacts, and burned or deteriorated rubber insert.
 - (4) Replace a broken or excessively burned contact by withdrawing the cable and contact from the rubber insert and soldering a new contact on the

cable.

- (5) Replace a defective slave receptacle or bracket.

c. Installation.

- (1) Position the slave receptacle mounting bracket in place on the skid and secure with screws, lockwashers, and nuts.
- (2) Secure slave receptacle in mounting bracket with screws, lockwashers, and nuts.
- (3) Reconnect leads.

4-25. Time Totalizing Meter (M4).

CAUTION

When working inside the control panel, disconnect plug P1 to prevent battery voltage arcing.

a. Removal. Refer to figure 4-24 and the following instructions to remove the time totalizing meter.

- (1) Tag and disconnect electrical leads from the time totalizing meter.
- (2) Remove nuts, washer, and screws securing the time totalizing meter to the control panel.
- (3) Remove meter.

NOTE: TAG AND DISCONNECT ELECTRICAL LEADS
AND REMOVE ATTACHING HARDWARE AS NECESSARY

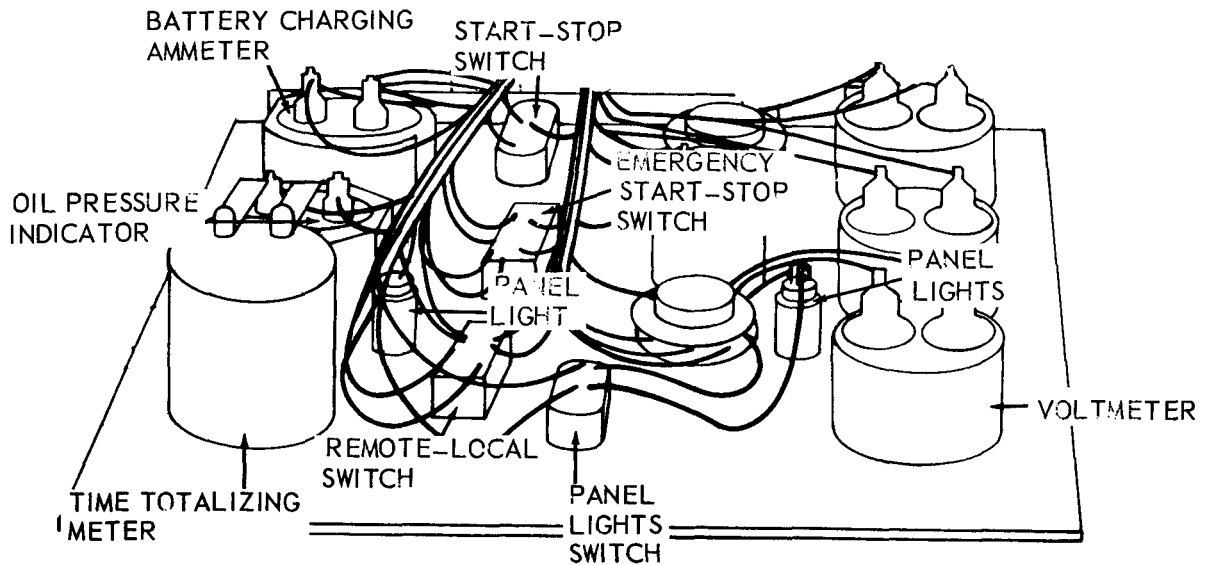

TS 6115-332-14/4-24

Figure 4-24. Control panel controls, instruments, and panel lights, removal and installation.

b. Cleaning, Inspection and Repair.

- (1) Carefully and thoroughly clean the exterior of the time totalizing meter with a clean lint free cloth.
- (2) Inspect meter for signs of burned areas, damaged threads, dents, loosened or corroded contacts, and for chipped or broken glass.
- (3) Replace a defective time totalizing meter.

CAUTION

When installing the time totalizing meter be certain that all wire leads are returned to the correct terminals. If these instructions are not followed, serious damage will result.

c. Installation.

- (1) Position the time totalizing meter in place on the control panel.
- (2) Secure with screws, washers, and nuts.
- (3) Reconnect leads.

4-26. Oil Pressure Indicator (M2).

CAUTION

When working inside the control panel, disconnect plug P1 to prevent battery voltage arcing.

a. Removal. Refer to figure 4-24 and the following instructions to remove the oil pressure indicator.

(1) Tag and disconnect electrical leads from the oil pressure indicator.

(2) Remove nuts, washers and shield securing the oil pressure indicator to the control panel.

(3) Remove oil pressure indicator.

b. Cleaning, Inspection and Repair.

(1) Carefully and thoroughly clean the exterior of the time totalizing meter with a clean lint free cloth.

(2) Inspect oil pressure indicator for signs of burned areas, damaged threads, loose or corroded terminals, and for chipped or broken glass.

(3) Replace a defective oil pressure indicator.

c. Installation.

CAUTION

When installing the oil pressure indicator be certain that all wire leads are returned to the correct terminals. If these instructions are not followed, serious damage will result.

(1) Position the oil pressure indicator in place on the control panel.

(2) Secure to panel with shield, washers and nuts.

(3) Reconnect leads.

d. Testing. Test with a multimeter for continuity.

4-27. Remote-Local Switch (S5).

CAUTION

When working inside the control panel, disconnect plug P1 to prevent battery voltage arcing.

a. Removal. Refer to figure 4-24 and the following instructions to remove the remote-local switch.

(1) Tag and disconnect all electrical leads from the remote-local switch.

(2) Remote nut and washer securing remote-local switch to the control panel.

(3) Remove remote-local switch.

b. Cleaning, Inspection and Repair.

(1) Clean the remote-local switch with a clean lint free cloth.

(2) Inspect switch for corroded terminals, loose contacts, signs of burned areas, thread damage, or cracks.

(3) Replace a damaged or defective remote-local switch.

c. Installation.

CAUTION

When installing the remote-local switch be certain that all wire leads are returned to the correct terminals. If these instructions are not followed, serious damage will result.

(1) Position remote-local switch in place on control panel and secure with washer and nut.

(2) Reconnect leads.

d. Testing. Test with a multimeter for continuity of switch contacts.

4-28. Start-Stop Switch (S4).

CAUTION

When working inside the control panel, disconnect plug P1 to prevent battery voltage arcing.

a. Removal. Refer to figure 4-24 and the following instructions to remove the start-stop switch.

(1) Tag and disconnect leads from the start-stop switch.

(2) Remove nut and washer securing the start-stop switch to the control panel.

(3) Remove start-stop switch.

b. Cleaning, Inspection and Repair.

(1) Clean the start-stop switch with a clean lint free cloth.

(2) Inspect switch for corroded terminals, loose contacts, signs of burned areas, thread damage, or cracks.

(3) Inspect switch for proper operation.

(4) Replace a damaged or defective switch.

c. Installation.

CAUTION

When installing the start-stop switch be certain that all wire leads are returned to the correct terminals. If these instructions are not followed, serious damage will result.

(1) Position start-stop switch in position on the control panel and secure with washer and nut.

(2) Reconnect all leads.

d. Testing. Test with a multimeter for continuity of switch contacts.

4-29. Battery Charging Ammeter (M3).

CAUTION

When working inside the control panel, disconnect plug P1 to prevent battery voltage arcing.

a. Removal. Refer to figure 4-24 and the following instructions to remove the battery charging ammeter.

(1) Tag and disconnect electrical leads from the battery charging ammeter.

(2) Remove nuts, washers, and shield securing the battery charging ammeter to the control panel.

(3) Remove ammeter.

b. Cleaning, Inspection and Repair.

(1) Carefully and thoroughly clean the exterior of the battery charging ammeter with a clean lint free cloth.

(2) Inspect the battery charging ammeter for signs of burned areas, damaged threads, loose or corroded terminals, and for chipped or broken glass.

(3) Replace a damaged or defective ammeter.

c. Installation.

CAUTION

When installing the battery charging ammeter, be certain that all wire leads are returned to the correct terminals. If these instructions are not followed, serious damage will result.

(1) Position the battery charging ammeter in place on the control panel and secure with shield, washers, and nuts.

(2) Reconnect all leads.

d. Testing. Test battery charging ammeter leads with a multimeter for continuity.

4-30. Emergency Stop-Run Switch (S6).

CAUTION

When working inside the control panel, disconnect plug P1 to prevent battery voltage arcing.

a. Removal. Refer to figure 4-24 and the following instructions to remove the emergency stop-run switch.

(1) Tag and disconnect electrical leads from the emergency stop-run switch.

(2) Remove nut and washer (from the front of the control panel) securing the emergency stop-run switch to the control panel.

(3) Remove emergency stop-run switch.

b. Cleaning, Inspection and Repair.

(1) Clean the emergency stop-run switch with a clean lint free cloth.

(2) Inspect switch for signs of burned areas, loose or corroded terminals, cracks, or thread damage.

(3) Inspect switch for proper operation.

(4) Replace a defective emergency stop-run switch.

c. Installation.

CAUTION

When installing the emergency stop-run switch, be certain that all wire leads are returned to the correct terminals. If these instructions are not followed, serious damage will result.

(1) position the emergency stop-run switch in place on the control panel and secure with washer and nut.

(2) Reconnect leads.

d. Testing. Test leads with a multimeter for continuity.

4-31. Panel Lights Switch (S7).

CAUTION

When working inside the control panel, disconnect plug P1 to prevent battery voltage arcing.

a. Removal. Refer to figure 4-24 and the following instructions to remove the panel lights switch.

(1) Tag and disconnect electrical leads from the panel lights switch.

(2) Remove nut and washer (from the front of the control panel) securing the panel lights switch to the control panel.

(3) Remove panel lights switch.

b. Cleaning, Inspection and Repair.

(1) Clean the panel lights switch with a clean lint free cloth.

(2) Inspect switch for signs of burned areas, loose or corroded terminals, cracks, or thread damage.

(3) Inspect switch for proper operation.

(4) Replace a damaged or defective switch.

c. Installation.

CAUTION

When installing the panel lights switch be certain that all wire leads are returned to the correct terminals. If these instructions are not followed, serious damage will result.

(1) Position panel lights switch in place on control panel and secure with washer and nut.

(2) Reconnect all leads.

d. Testing. Test with a multimeter for continuity of switch contacts.

4-32. Panel Light (XDS1 and XDS2).

CAUTION

When working inside the control panel, disconnect plug P1 to prevent battery voltage arcing.

a. Removal. Refer to figure 4-24 and the following instructions to remove the panel light.

(1) Tag and disconnect electrical leads from the panel light.

(2) Remove panel light shield (from the front of the control panel) by pulling straight out.

(3) Remove panel light bulb by depressing and turning counterclockwise.

(4) Remove nut and washer (from back of control panel) securing panel light to the control panel.

(5) Remove Panel light.

(6) Remove the other panel light in the same manner.

b. Cleaning, Inspection and Repair.

(1) Clean the panel light(s) using a clean lint free cloth.

(2) Inspect light(s) for loose contacts, cracks, breaks, or burned sockets.

(3) Inspect bulb for corroded pins or base and for a burned out condition.

(4) Replace damaged or defective panel light or bulb.

c. Installation.

CAUTION

When installing the panel light(s), be certain that all wire leads are returned to the correct terminals. The lead from the switch must go to the positive, or center, terminal of the panel light. If these instructions are not followed, serious damage will result.

(1) Position panel light in place on control panel and secure with washer and nut.

(2) Insert panel light bulb into light socket. Depress bulb and with a clockwise motion secure in lamp socket.

(3) Install light shield by pushing straight in until shield snaps into place.

(4) Reconnect leads.

(5) Install the other light in the same manner.

d. Testing. Test with a multimeter for continuity of switch contacts.

Section IX. MAINTENANCE OF THE GENERATOR ELECTRICAL SYSTEM

WARNING

Always stop the generator set before performing maintenance on the electrical system components. Failure to observe this warning may lead to severe injury or to death by electrocution.

4-33. AC Voltmeter (M6).

a. Removal. Refer to figure 4-24 and the following instructions to remove the AC Voltmeter.

(1) Tag and disconnect leads from the AC voltmeter.

(2) Remove nuts, washers, and screws securing the AC voltmeter to the control panel.

(3) Remove the voltmeter.

b. Cleaning, Inspection and Repair.

(1) Carefully and thoroughly clean the exterior of the voltmeter with a clean lint free cloth.

(2) Inspect the voltmeter for signs of burned areas, damaged threads, loosened contacts, and for loose or broken glass.

(3) Replace a damaged or defective voltmeter.

c. Installation.

(1) Secure voltmeter to the control panel with screws, washers, and nuts.

(2) Reconnect wiring.

d. Testing. Test voltmeter by connecting an additional voltmeter to load terminals of generator set and taking comparative reading to establish validity of generator set voltmeter.

4-34. Frequency Meter (M1).

a. Removal. Refer to figure 4-24 and the following instructions to remove the frequency meter.

(1) Tag and disconnect leads from the frequency meter.

(2) Remove nuts, washers, and screws securing the frequency meter to the control panel.

(3) Remove frequency meter.

b. Cleaning, Inspection and Repair.

(1) Carefully and thoroughly clean the exterior surfaces of the frequency meter with a clean lint free cloth.

(2) Inspect the frequency meter for signs of burned areas, damaged threads, loosened contacts, and for loose or broken glass.

(3) Replace a damaged or defective frequency meter.

c. Installation.

(1) Position frequency meter in place on control panel and secure with screws, washers, and nuts.

(2) Reconnect leads.

d. Testing.

(1) Disconnect frequency meter leads and connect a frequency meter of known quality and take comparative readings to establish validity of generator set frequency meter.

(2) Reconnect leads.

4-35. Current Indicator Meter (M5).

a. Removal. Refer to figure 4-24 and the following instructions to remove the current indicator meter.

(1) Tag and disconnect leads.

(2) Remove nuts, washers, and screws securing the current indicator meter to the control panel.

(3) Remove the current indicator meter.

b. Cleaning, Inspection and Repair.

(1) Carefully and thoroughly clean the exterior surfaces of the current indicator meter with a clean lint free cloth.

(2) Inspect the current indicator meter for signs of burned areas, damaged threads, loosened terminals, and for loose & broken glass.

(3) Replace a damaged or defective current indicator meter.

c. Installation.

(1) Position the current indicator meter in place on the control panel and secure with screws, washers, and nuts.

(2) Reconnect leads.

d. Testing.

(1) Disconnect current indicator meter and connect a current indicator meter of known quality and take comparative readings to establish validity of generator set current indicator meter.

(2) Reconnect leads.

4-36. Ammeter Phase Selector Switch (S2).

a. Removal. Refer to figure 4-24 and the following instructions to remove the ammeter phase selector switch.

(1) Tag and disconnect leads from the ammeter phase selector switch.

(2) Loosen setscrew securing control knob on the ammeter phase selector switch and remove knob.

(3) Remove locking nut and washer securing the ammeter phase selector switch to the control panel.

(4) Remove the ammeter phase selector switch.

b. Cleaning, Inspection and Repair.

(1) Carefully and thoroughly clean the exterior surfaces of the ammeter phase selector switch using a clean lint free cloth.

(2) Inspect switch for signs of burned areas, damaged threads, cracks, or loosened contacts.

(3) Replace a damaged or defective ammeter phase selector switch.

c. Installation.

(1) Position the ammeter phase selector switch in place on the control panel and secure with washer and nut.

(2) Place control knob over end of switch shaft and secure by tightening setscrew.

(3) Reconnect leads.

d. Testing. Using a multimeter check for continuity of switch contacts in all positions.

4-37. Voltage Selector Switch (S3).

a. Removal. Refer to figure 4-24 and the following instructions to remove the voltage selector switch.

(1) Tag and disconnect leads from the voltage selector switch.

(2) Loosen setscrew securing control knob on the voltage selector switch and remove control knob.

(3) Remove locking nut and washer securing the voltage selector switch to the control panel.

(4) Remove the voltage selector switch.

b. Cleaning, Inspection and Repair.

(1) Carefully and thoroughly clean the exterior surfaces of the voltage selector switch with a clean lint free cloth.

(2) Inspect the switch for signs of burned areas, damaged threads, cracks or for loosened or corroded contacts.

(3) Replace a damaged or defective voltage selector switch.

c. Installation.

(1) Position the voltage selector switch in place on the control panel and secure with washer and locking nut.

(2) Place control knob over end of switch shaft and secure by tightening setscrew.

(3) Reconnect leads.

d. Testing. Using a multimeter, check for continuity of switch contacts in all positions.

4-38. Voltage Adjusting Rheostat (R1).

a. Removal. Refer to figure 4-24 and the following instructions to remove the voltage adjusting rheostat.

(1) Tag and disconnect the leads from the voltage adjusting rheostat.

(2) Loosen the setscrew securing the voltage adjusting rheostat knob on the rheostat and remove the control knob.

(3) Remove locking nut and washer securing the voltage adjusting rheostat to the control panel.

(4) Remove the voltage adjusting rheostat.

b. Cleaning, Inspection and Repair.

(1) Carefully and thoroughly clean the exterior surfaces of the voltage adjusting rheostats using a clean lint free cloth.

(2) Inspect rheostat for signs of burned areas, damaged threads and for loosened or corroded contacts.

(3) Replace a damaged or defective rheostat.

c. Installation.

(1) Position the voltage adjusting rheostat in place on the control panel and secure with washer and locking nut.

(2) Place rheostat knob over end of shaft and secure with setscrew.

(3) Reconnect leads.

d. Testing. Test voltage adjusting rheostat as follows:

(1) With the electrical leads disconnected from the rheostat connect a multimeter to the two outside terminals. The resistance should measure not more than 11 or not less than 9 ohms.

(2) Connect the multimeter between the center terminal and one of the outside terminals. Turn the shaft of the rheostat from one extreme position to the other. The resistance should vary smoothly from zero to maximum.

4-39. Wiring Harness.

The wiring harness and wire leads used on these generator sets consist of individual wire leads and terminals, and wire leads strapped into a harness by plastic wire straps. Repair worn, damaged, or broken individual wire leads. Follow the wiring diagrams, shown as figures FO-1 and FO-3 and tag for proper identification all wire leads that are to be repaired.

4-40. Fuseholder (XF) (Model MEP-017A).

a. Removal. Refer to figure 4-25 and the following instructions to remove the fuseholder.

(1) Tag and disconnect electrical leads as necessary.

(2) Remove fuses.

(3) Remove nuts, lockwashers and screws securing the fuseholder and remove fuseholder.

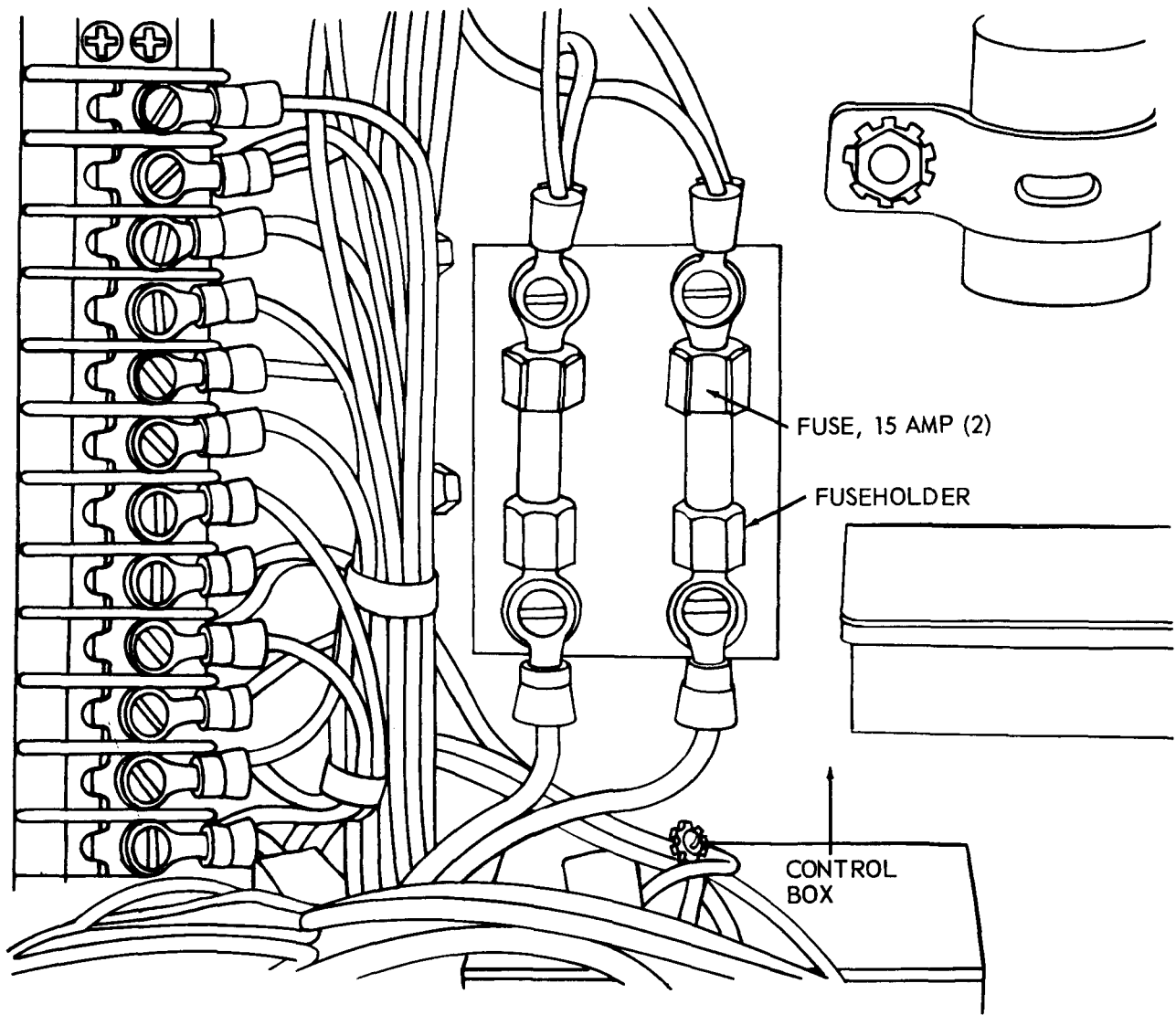

TS 6115-332-14/3-25

Figure 4-25. Fuseholder, removal and installation (Model MEP-017A).

b. Cleaning, Inspection and Repair.

WARNING

Clean all parts in a well-ventilated area. Avoid inhalation of solvent fumes and prolonged exposure of skin to cleaning solvent. Wash exposed skin thoroughly. Dry cleaning solvent (Fed. Spec. P-D-680, Type II) used to clean parts is potentially dangerous to personnel and property. Do not use near open flame or excessive heat. Flash point of solvent is 140 °F (60°C).

(1) Clean fuseholder and mounting hardware items with cleaning solvent, Fed. Spec. P-D-680, Type II, and dry thoroughly.

(2) Inspect the fuseholder for burned, loose, or broken clips.

(3) Inspect the body of the fuseholder for cracks and other damages.

(4) Replace a defective fuseholder.

c. Installation.

NOTE

Be sure fuses are the correct size and rating.

(1) Position fuseholder in place and secure with screws, lockwashers, and nuts.

(2) Install fuses.

4-41. Circuit Breaker (CB).

NOTE

To facilitate installation of the circuit breaker, before removal of the wire leads from the terminals at the back of the unit, make a diagram that shows the exact position of each lead. It will be found that if the leads are allowed to turn from their original position they will be too short to enable the successful installation of the circuit breaker.

a. Removal. Refer to figure 4-26 and the following instructions to remove the circuit breaker.

(1) Tag and disconnect leads.

(2) Remove screws and lockwashers securing the circuit breaker to the control panel and remove the circuit breaker.

NOTE: LOOSEN CIRCUIT BREAKER FROM CONTROL PANEL THEN IDENTIFY AND DISCONNECT LEADS, SEE NOTE IN TEXT.

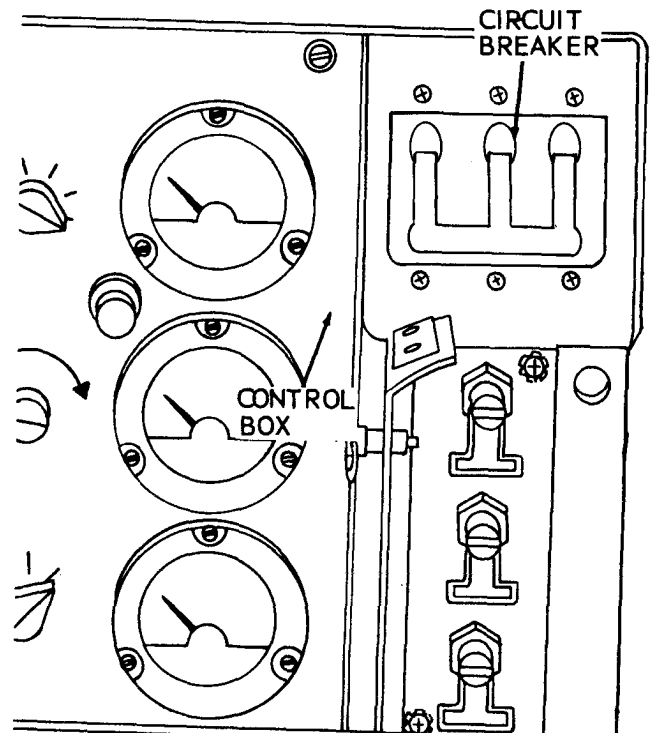

TS 6115-332-14/4-26

Figure 4-26. circuit breaker, removal and installation.

b. Cleaning.

WARNING

Clean all parts in a well-ventilated area. Avoid inhalation of solvent fumes and prolonged exposure of skin to cleaning solvent. Wash exposed skin thoroughly. Dry cleaning solvent (Fed. Spec. P-D-680, Type II) used to clean parts is potentially dangerous to personnel and property. Do not use near open flame or excessive heat. Flash point of solvent is 140°F (60°C).

(1) Clean the exterior portion of the circuit breaker with a cloth dampened in cleaning solvent, Fed. Spec. P-D-680, Type II, and dry thoroughly.

(2) Inspect the circuit breaker for a cracked case and for signs of scorched or burned areas.

(3) Inspect the terminals for damage and stripped threads.

(4) Operate the unit and inspect for proper operation. When moved to the ON position, the breaker should hold and should not trip OFF.

(5) Replace a defective circuit breaker.

c. **Installation.**

(1) Position circuit breaker in place and secure with lockwashers and screws.

(2) Reconnect all leads.

4-42. Control Relays (K1, K2, K3, and K4).

a. **Removal.** Refer to figure 4-27 and the following instructions to remove the control relays.

(1) Remove screws and lockwashers securing the control relays in the relay sockets.

(2) Remove relays by pulling straight out.

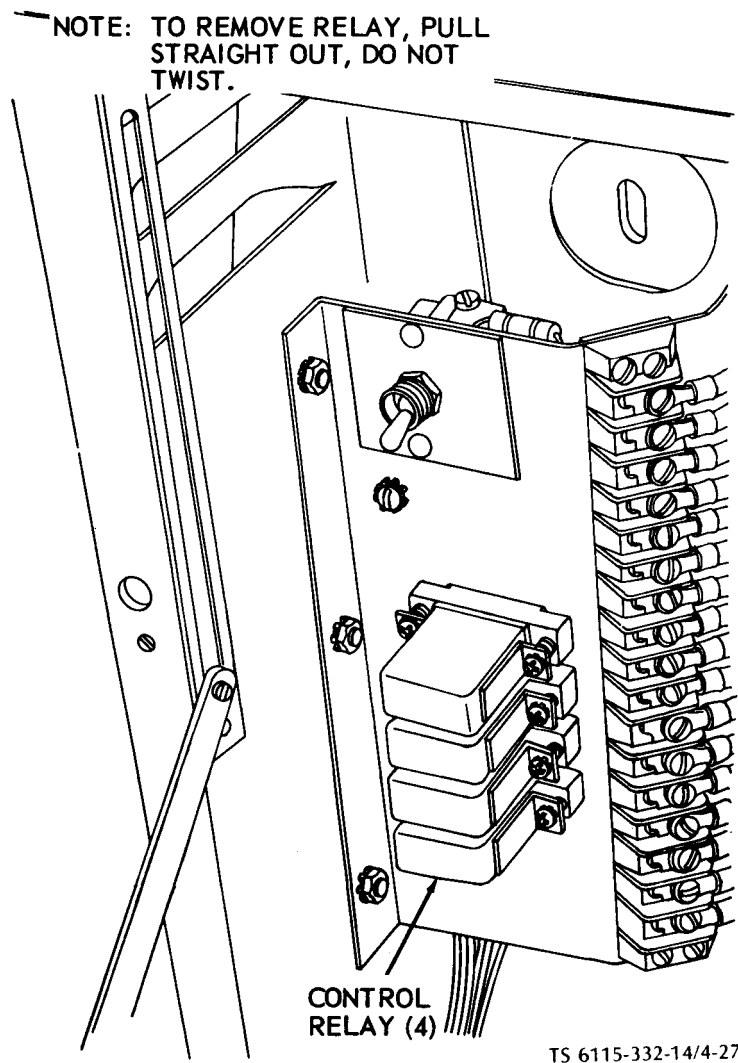

Figure 4-27. Control relays, removal and installation-

b. Cleaning, Inspection and Repair.

WARNING

Clean all parts in a well-ventilated area. Avoid inhalation of solvent fumes and prolonged exposure of skin to cleaning solvent. Wash exposed skin thoroughly. Dry cleaning solvent (Fed. Spec. P-D-680, Type II) used to clean parts is potentially dangerous to personnel and property. Do not use near open flame or excessive heat. Flash point of solvent is 140°F (60°C).

- (1) Clean the exterior of the control relays carefully with a cloth dampened in cleaning solvent, Fed. Spec. P-D-680, Type II, and dry thoroughly. ■
- (2) Inspect for burned, broken, or missing contact pins.
- (3) Inspect the cases for cracks, breakage and other damage.
- (4) Replace a damaged control relay.

c. Testing.

- (1) Refer to figure 4-28 for identification of the contact pins.

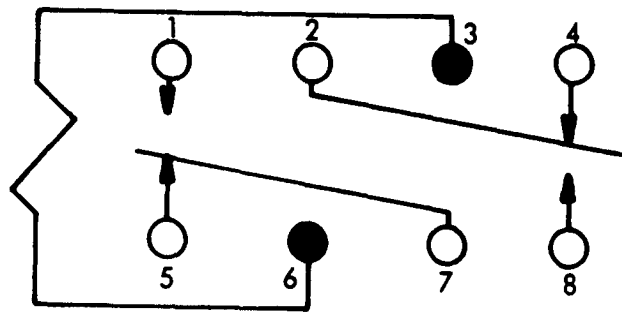

TS-6115-332-14/4-28

Figure 4-28. Relay, internal connection diagram.

NOTE

The bases of two of the pins are colored black and enable the user to properly orient the unit. The pins are not actually numbered on the relay, but are numbered on the illustration so the individual pins can be identified in the text.

(2) Use a multimeter and test between 2 and 4. There should be continuity. Then, test between 2 and all other pins except 4. There should be no continuity.

(3) Test between pins 5 and 7. There should be continuity. Now, test between pin 7 and all other pins except 5. There should be no continuity between pin 7 and the other pins.

(4) Apply a source of 24-volt dc power to pins 3 and 6. This should operate the relay.

CAUTION

When testing the relay with a source of power, do not allow the test probes to contact pins 3 and 6 as damage to the test instrument may result.

(5) With the power applied, test between pins 2 and 8. There should be continuity. Next, test between pins 2 and pins 4, and 5. There should be no

continuity.

(6) Continue the test with the power applied and test between pins 7 and 1. There should be continuity. Now, test between pin 7 and pins 5, 4, and 8. There should be no continuity.

(7) Replace a relay that fails to pass any of the tests above.

d. Installation.

NOTE

When installing relays, push straight in. Do not twist as pins will be damaged.

(1) Install relays.

(2) Secure relays in socket with lockwashers and screws.

4-43. Outlet Receptacle (J1). (Model MEP-017A).

a. Removal. Refer to figure 4-29 and the following instructions to remove the outlet receptacle.

(1) Remove screws and lockwashers securing the receptacle cover to the control box.

(2) Remove receptacle cover and gasket.

(3) Remove screws and lockwashers securing the duplex receptacle.

(4) Slide receptacle forward. Tag and disconnect electrical leads and remove the receptacle.

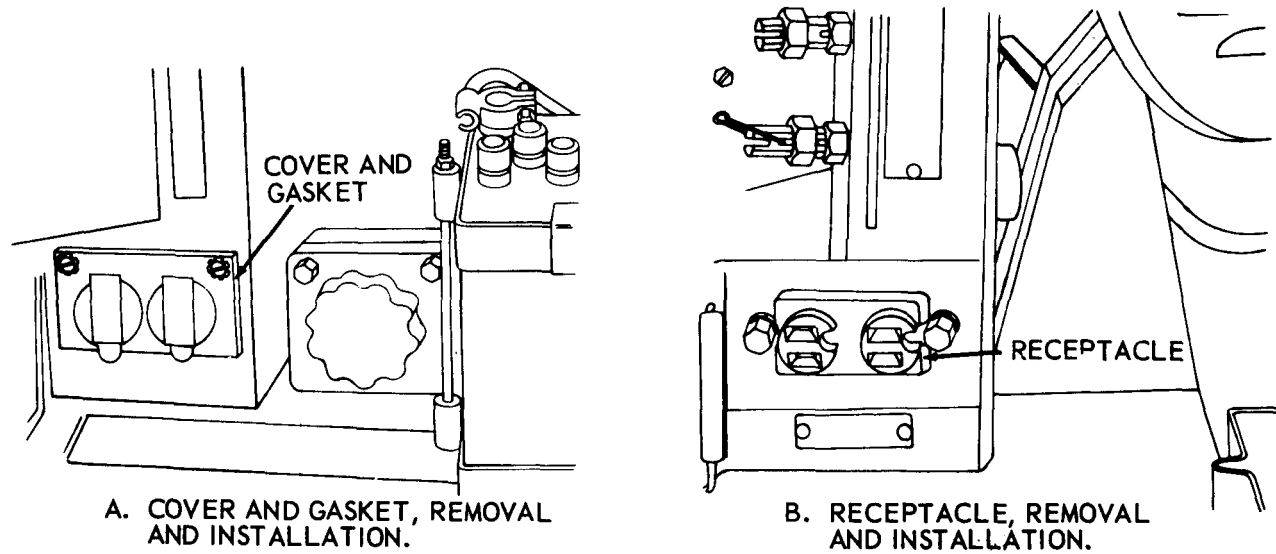

TS 6115-332-14/4-29

Figure 4-29. Outlet receptacle (J1) (Model MEP-017A)

b. Cleaning, Inspection and Repair.

WARNING

Clean all parts in a well-ventilated area. Avoid inhalation of solvent fumes and prolonged exposure of skin to cleaning solvent. Wash exposed skin thoroughly. Dry cleaning solvent (Fed. Spec. P-D-680, Type II) used to clean parts is potentially dangerous to personnel and property. Do not use near open flame or excessive heat. Flash point of solvent is 140°F (60°C).

- (1) Clean the exterior surfaces with a clean cloth dampened in cleaning solvent, Fed. Spec. P-D-680, Type II, and dry thoroughly.
- (2) Inspect the receptacle for burned contacts

and for cracks and other damage.

- (3) Replace a defective outlet receptacle.

c. Installation.

- (1) Reconnect electrical leads to the duplex receptacle.
- (2) Secure receptacle in the control box with lockwashers and screws.
- (3) Position receptacle cover gasket and cover in place on control box and secure with lockwashers and screws.

4-44. Top Resilient Mounts.

a. Removal. Refer to figure 4-30 and the following instructions to remove the resilient mounts.

- (1) Remove screws and washers securing the top resilient mounts to the control box.
- (2) Remove nuts, washers, and screws securing the resilient mounts to the control box bracket.
- (3) Remove the resilient mounts.

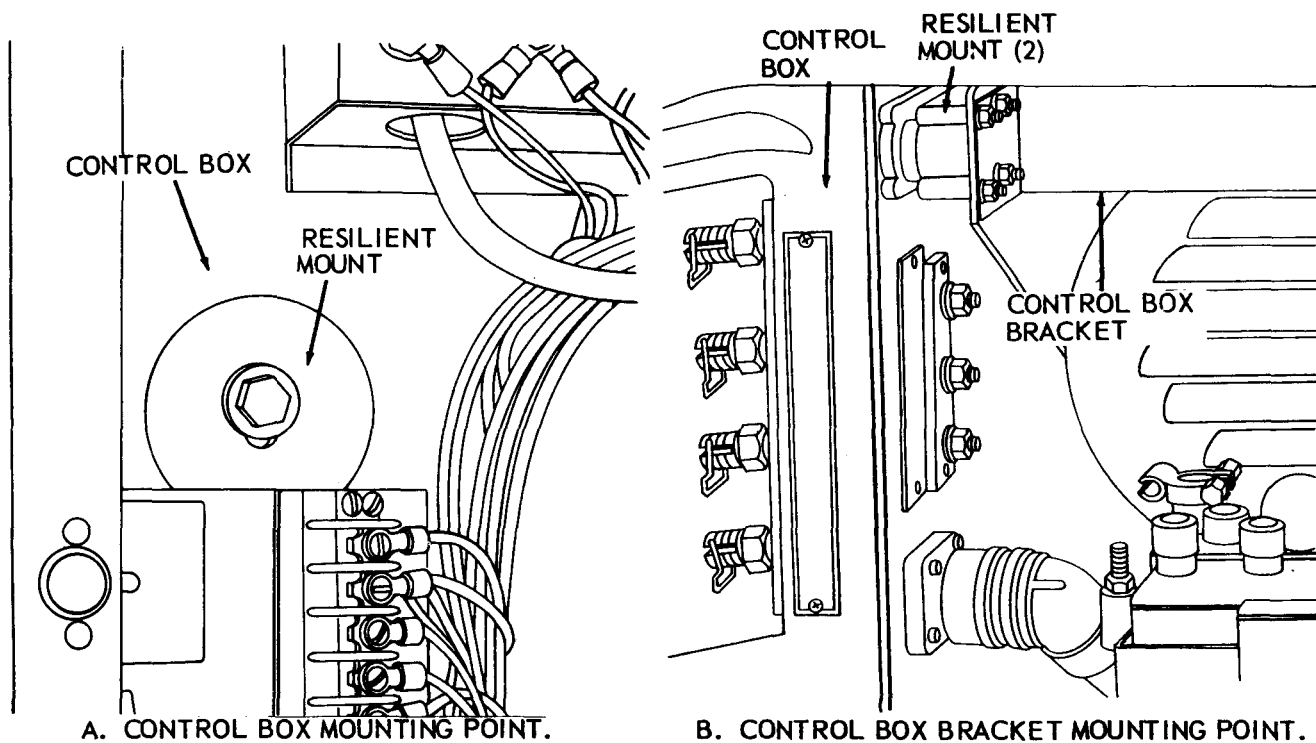

TS 6115-332-14/4-30

Figure 4-30. Top resilient mounts, removal and installation.

b. Cleaning, Inspection and Repair.

WARNING

Clean all parts in a well-ventilated area. Avoid inhalation of solvent fumes and prolonged exposure of skin to cleaning solvent. Wash exposed skin thoroughly. Dry cleaning solvent (Fed. Spec. P-D-680, Type II) used to clean parts is potentially dangerous to personnel and property. Do not use near open flame or excessive heat. Flash point of solvent is 140 °F (60 °C).

- (1) Clean item with cleaning solvent,

Fed. Spec. P-D-680, Type II, and dry thoroughly. ■

(2) Inspect the top resilient mounts for stripped threads, loose threaded inserts, and for cracks and deterioration of the mount body.

(3) Replace a defective resilient mount.

c. Installation.

(1) Position top resilient mounts in place on the control box bracket and secure with screws, lockwashers and nuts.

(2) Install washers and screws securing the top resilient mounts to the control box.

4-45. Control Box Bracket.

a. Removal.

(1) Remove the nuts, lockwashers and screws that secure the toolbox on the toolbox bracket. Refer to figure 4-31.

TM 5-6115-332-14
P-8-614-14
TO 35C2-3-424-1

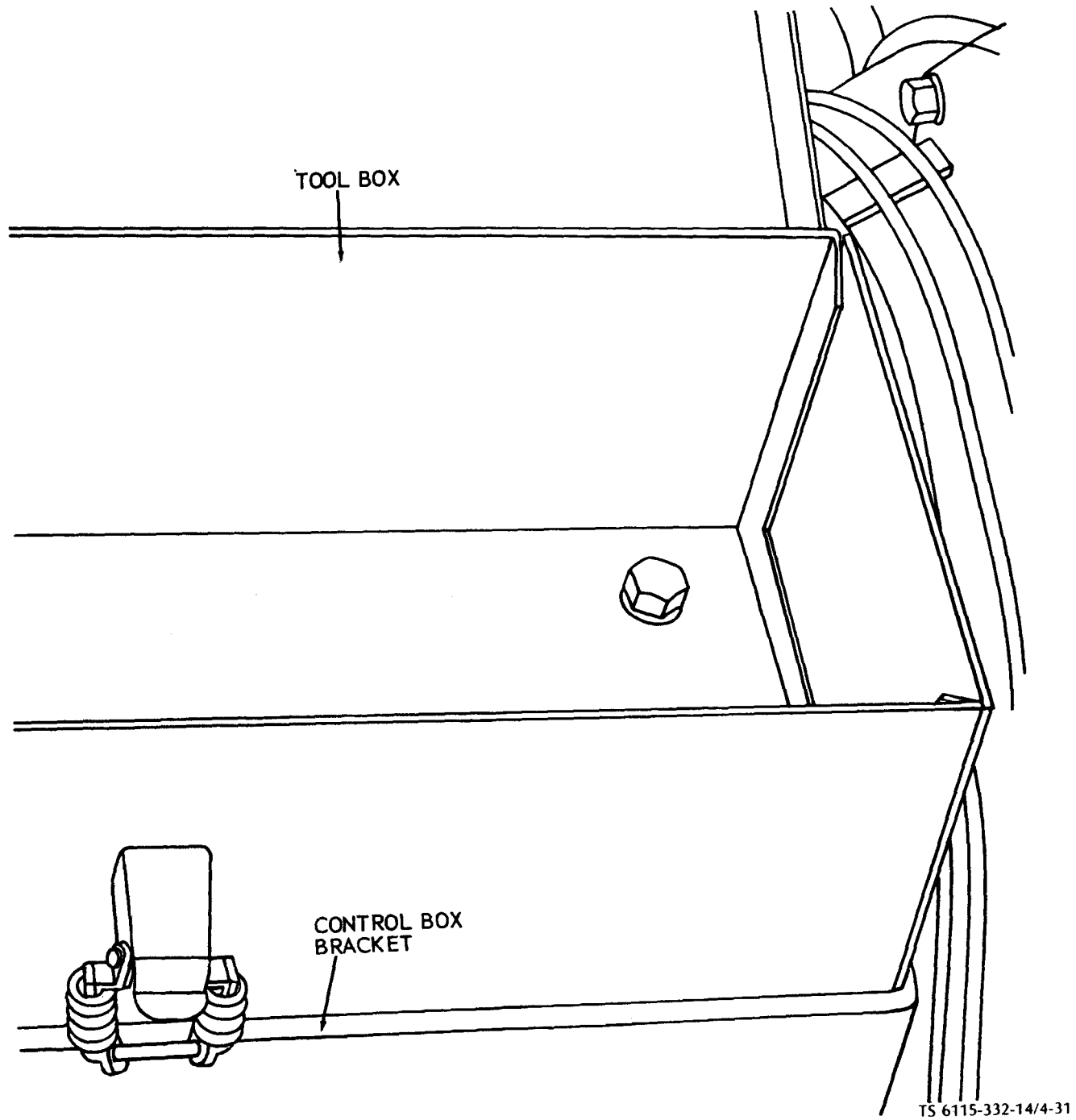

TS 6115-332-14/4-31

Figure 4-31. Toolbox, removal and installation.

- (2) Remove the top resilient mounts (para 4-44).
- (3) Refer to figure 4-32, View A, and remove the screw and lockwashers securing the control box bracket to the side of the generator housing.

- (4) Refer to figure 4-32, View B, and remove the lifting eye and screw and lockwasher securing the control box bracket to the top of the generator housing.
- (6) Remove the control box bracket.

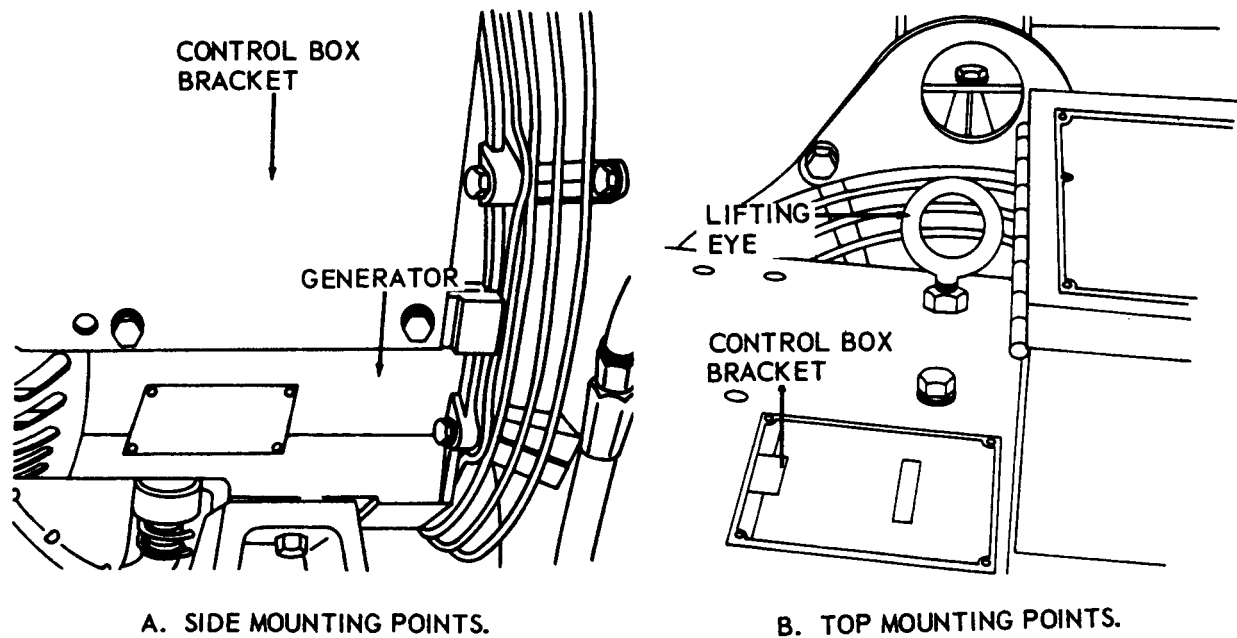

Figure 4-32. Control box bracket, removal and installation.

b. Cleaning, Inspection and Repair.

WARNING

Clean all parts in a well-ventilated area. Avoid inhalation of solvent fumes and prolonged exposure of skin to cleaning solvent. Wash exposed skin thoroughly.

Dry cleaning solvent (Fed. Spec. P-D-680, Type II) used to clean parts is potentially dangerous to personnel and property. Do not use near open flame or excessive heat. Flash point of solvent is 140° F (60° C).

TS 6115-332-14/4-32

(1) Clean items with cleaning solvent, Fed. Spec. P-D-680 Type II, and dry thoroughly.

(2) Inspect the bracket for dents, cracks and distortion.

(3) Straighten a distorted or dented bracket.

(4) Weld cracks and grind the welds smooth.

(5) Replace a defective control box bracket.

c. Installation.

(1) Position the control box bracket in place and install lockwasher and screw and lifting eye to the top of the generator housing.

(2) Install lockwashers and screws that secure the control box bracket to the side of the generator housing.

(3) Refer to paragraph 4-44 and install the top resilient mounts.

(4) Install the screws, lockwashers, and nuts that secure the toolbox to the toolbox bracket. Refer to figure 4-31.

4-45A. Replace Lost or Broken Terminal Clip (Retainer, Safety Clip).

The terminal clip is a component of both the load terminal and the ground terminal. If terminal clip is lost or broken, fabricate as follows: Requisition bull wire NSN 9505-01-049-0144, 0.050 inch diameter. Cut off about 3 inches of the wire. Cut the wire short enough to keep the clips from touching another terminal or the generator frame in the open or closed position. Slip the wire through the hole in the terminal and proceed as shown in the following views.

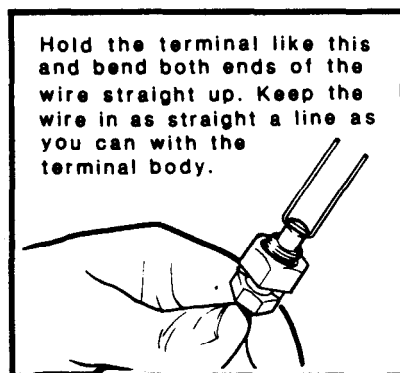

VIEW 1.

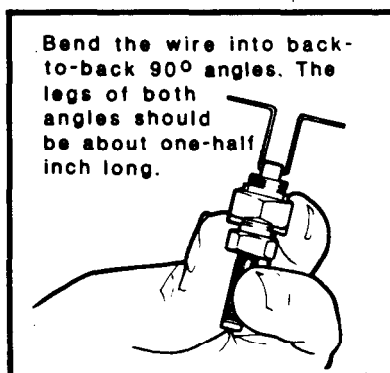

VIEW 2.

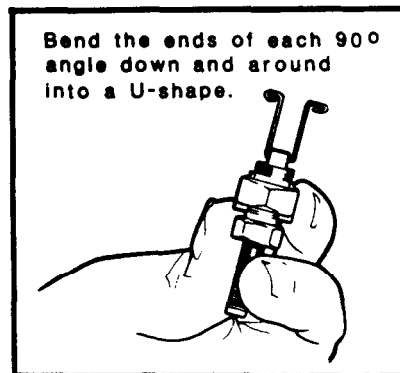

VIEW 3.

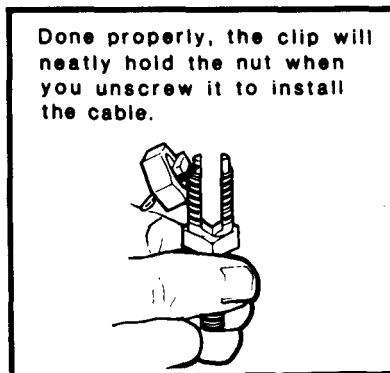

VIEW 4.

Section X. MAINTENANCE OF THE FRAME ASSEMBLY

4-46. General.

This section covers organizational maintenance for the lifting eye and lifting eye bracket, guard frame, and toolbox. These items are all identical on both the model MEP-017A and the model MEP-022A generator sets.

4-47. Guard Frame.

a. Removal. Refer to figure 4-33 and the following instructions to remove the guard frame.

(1) Remove the nuts, washers, and screws securing the guard frame to the skid base.

(2) Remove the screw and lockwasher that secures the guard frame to the flywheel housing.

(3) Remove guard frame from the generator set.

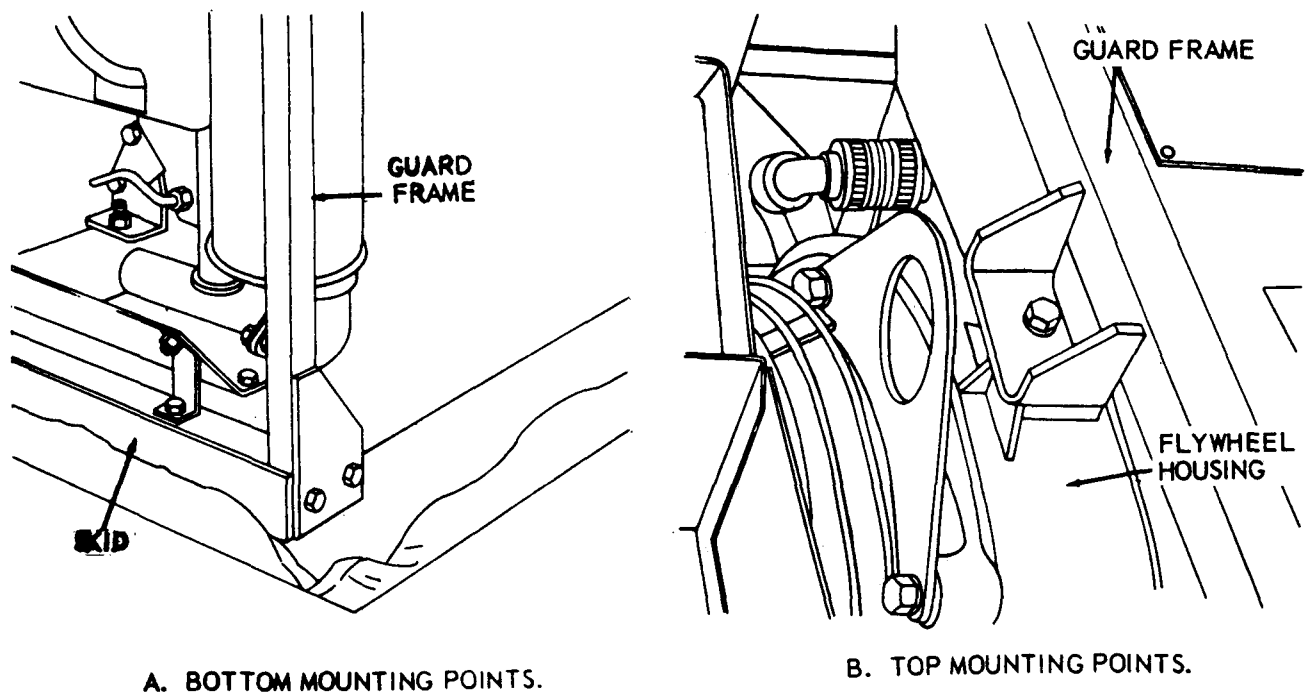

TS 6115-332-14 4-33

Figure 4-33. Guard frame, removal and installation.

b. Cleaning, Inspection and Repair.**WARNING**

Clean all parts in a well-ventilated area. Avoid inhalation of solvent fumes and prolonged exposure of skin to cleaning solvent. Wash exposed skin thoroughly.

- Dry cleaning solvent (Fed. Spec. P-D-680, Type II) used to clean parts is potentially dangerous to personnel and property. Do not use near open flame or excessive heat.
 - Flash point of solvent is 140°F (60°C).
- (1) Clean items with cleaning solvent, Fed. Spec. P-D-680, Type II, and dry thoroughly.
 - (2) Inspect the guard frame for dents, bent areas, cracks, and broken welds.

(3) Weld cracks and broken welds. Smooth up the welds by grinding.

- (4) Straighten any bent or twisted areas.
- (5) Replace a defective guard frame.

c. Installation.

(1) Position the guard frame in place and install lockwasher and screw that secures the guard frame to the flywheel housing.

(2) Install screws, lockwashers and nuts that secure guard frame to the skid base.

4-48. Lifting Eye and Lifting Bracket.

a. Removal. Refer to figure 4-34 and the following instructions to remove the lifting eye and lifting bracket.

(1) Loosen nut that secures the lifting eye to the toolbox bracket. Unscrew lifting eye.

(2) Remove screws and lockwashers which secure the lifting bracket to the flywheel housing the remove the lifting bracket.

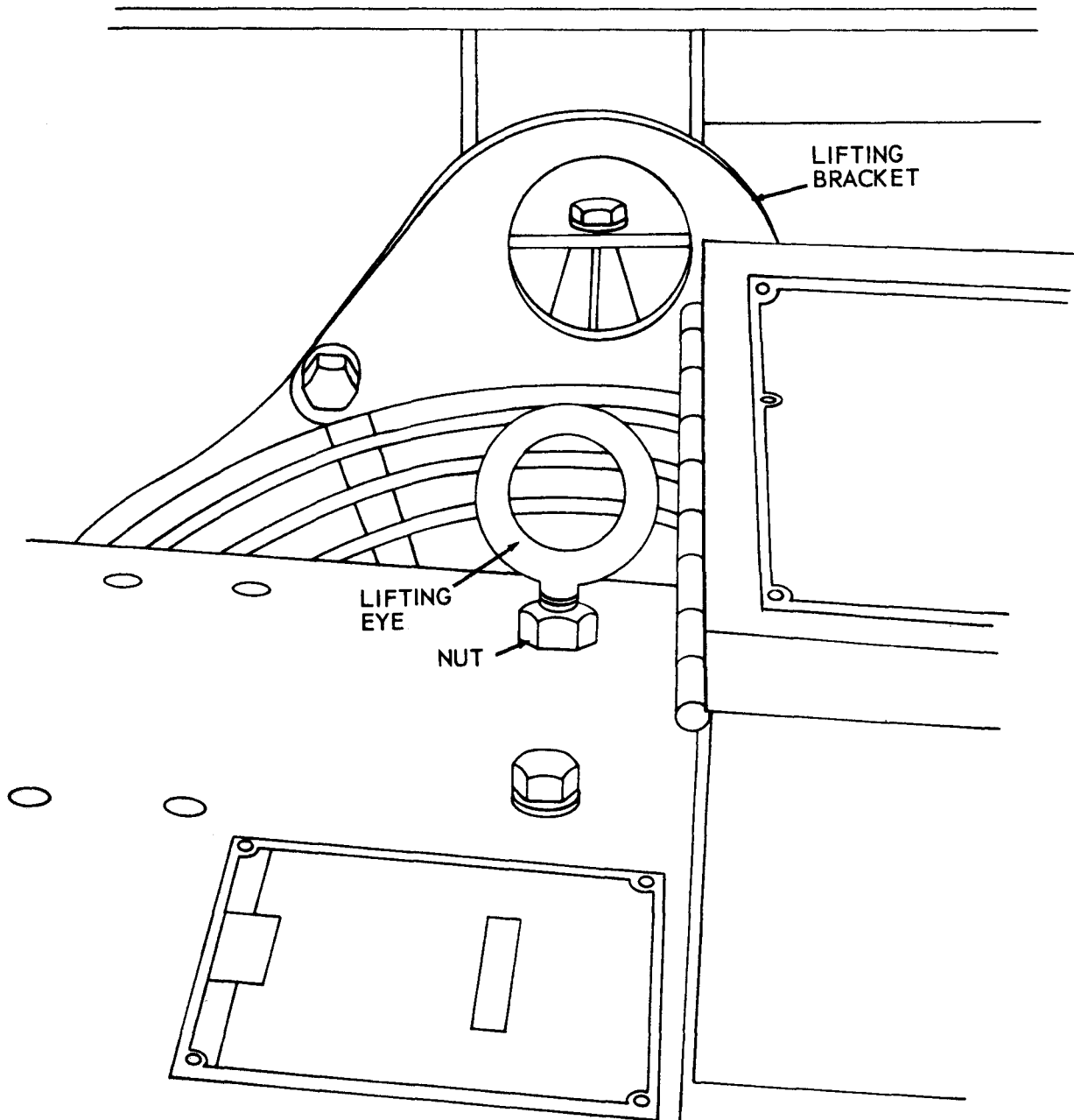

TS 6115-332-14/4-34

Figure 4-34. Lifting eye and lifting bracket, removal and installation.

b. Cleaning, Inspection and Repair.

WARNING

Clean all parts in a well-ventilated area. Avoid inhalation of solvent fumes and prolonged exposure of skin to cleaning solvent. Wash exposed skin thoroughly. Dry cleaning solvent (Fed. Spec. P-D-680, Type II) used to clean parts is potentially dangerous to personnel and property. Do not use near open flame or excessive heat. Flash point of solvent is 140° F (60 °C).

- (1) Clean items with cleaning solvent Fed. Spec. P-D-680 Type II, and dry thoroughly.
- (2) Inspect the lifting eye and lifting eye bracket for cracks and distortion.
- (3) Inspect the lifting eye for stripped or damaged threads.
- (4) Replace all defective parts.

c. Installation.

- (1) Install the lifting bracket to the flywheel housing with lockwashers and screws.
- (2) Thread lifting eye into hole provided on tool box bracket. Tighten nut to secure.

4-49. Ground Stud Terminal.

a. Removal. To remove the ground stud terminal (fig. 4-35), remove the nut and lockwasher that secure it to the skid base and remove the terminal.

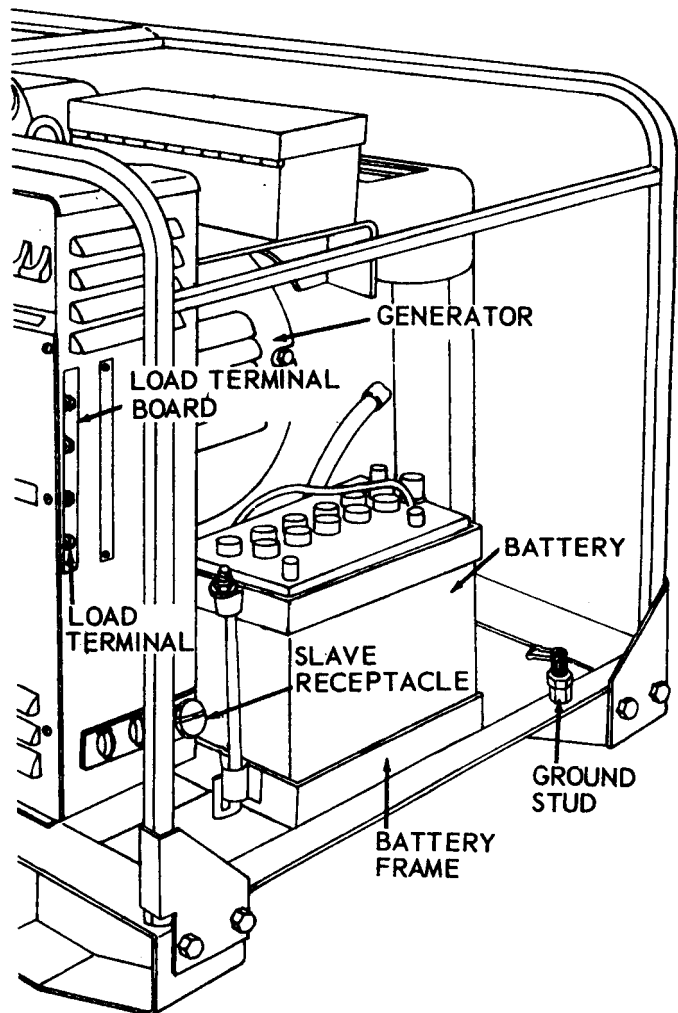

TS 6115-332-14/4-35

Figure 4-35. Ground terminal stud, removal and installation.

b. Cleaning, Inspection and Repair.

WARNING

Clean all parts in a well-ventilated area. Avoid inhalation of solvent fumes and prolonged exposure of skin to cleaning solvent. Wash exposed skin thoroughly. Dry cleaning solvent (Fed. Spec. P-D-680, Type II) used to clean parts is potentially dangerous to personnel and property. Do not use near open flame or excessive heat. Flash point of solvent is 140° F (60° C).

(1) Clean items with cleaning solvent Fed. Spec. P-D-680 Type II, and dry thoroughly.

(2) Inspect studs for cracks, breaks and wear.

(3) Replace a damaged stud.

c. Installation. Install ground terminal stud to skid base using lockwasher and nut.

d. Replace lost or broken terminal clip (Retainer, safety clip). For fabrication procedures, see paragraph 4-45A.

4-50. Toolbox

a. Removal. Refer to figure 4-31 and the following instructions to remove the toolbox.

(1) Remove the nuts, lockwashers, and screws which secure the toolbox to the toolbox mounting bracket.

(2) Remove the toolbox.

b. Cleaning, Inspection and Repair.

WARNING

Clean all parts in a well-ventilated area. Avoid inhalation of solvent fumes and prolonged exposure of skin to cleaning solvent. Wash exposed skin thoroughly. Dry cleaning solvent (Fed. Spec. P-D-MO, Type 11) used to clean parts is potentially dangerous to personnel and property. Do not use near open flame or excessive heat. Flash point of solvent is 140° F (60° C).

(1) Clean items with cleaning solvent Fed. Spec. P-D-680 Type H, and dry thoroughly.

(2) Inspect the toolbox for dents, broken welds and other damage.

(3) Weld cracks and grind the weld smooth.

(4) Straighten dents.

(5) Replace a defective toolbox.

c. Installation.

(1) Position toolbox in place on toolbox mounting bracket.

(2) Secure with screws, lockwashers and nuts.

CHAPTER 5

INTERMEDIATE (FIELD), (DIRECT AND GENERAL SUPPORT) AND DEPOT MAINTENANCE INSTRUCTIONS

Section I. REPAIR PARTS, SPECIAL TOOLS AND EQUIPMENT

5-1. Special Tools and Equipment

There are no special tools or equipment required by Direct and General Support Maintenance to Repair/Overhaul the generator set.

NOTE

Air Force users may perform maintenance within the scope of their capability.

5-2. Direct and General Support Maintenance Repair Parts

(A) Direct and General Support Maintenance Repair Parts are listed and illustrated in TM 5-6115-332-34P.

(F) Air Force users refer to TO 38G-89-34,

Section II. DS AND GS TROUBLESHOOTING

5-3. General

a. This section contains troubleshooting information for locating and correcting most of the DS and GS troubles which may develop in the generator set. Each malfunction for an individual component, unit, or system is followed by a list of tests or inspections which will help you to determine the probable causes and corrective actions in the order listed.

b. This manual cannot list all malfunctions that may occur, nor all tests or inspections and cor-

rective actions. If a malfunction is not listed or is not corrected by listed corrective actions, notify your supervisor.

5-4. Troubleshooting

NOTE

Before you use this table, be sure you have performed all applicable operating checks.

Refer to Table 5-1 for direct and general-support maintenance troubleshooting.

Table 5-1. DS and GS Troubleshooting

MALFUNCTION

TEST OR INSPECTION

CORRECTIVE ACTION

1. GENERATOR FAILS TO BUILD UP RATED VOLTAGE

Step 1. Check to see if the field flash switch is broken or cracked. Test as follows: Using a multimeter, check for continuity of the switch contacts. Test the field flash switch for continuity while the switch is held in the closed (ON) position.

If the field flash switch is damaged or defective replace it. Refer to paragraph 7-4 for removal and installation. If the switch is not defective, go on to Step 2.

Step 2. Test for a defective resistor as follows:

a. Disconnect the current transformer leads and remove the three resistors.

WARNING

Never disconnect the leads of a current transformer, either at the transformer or at a meter connected to the transformer, when the equipment is energized. The three resistors used with this equipment are connected across the secondary windings of the current transformer and they ordinarily prevent an open circuit condition. But, if a resistor were to fail and then the secondary was to be open circuited by disconnecting its load (the meter), extremely high voltages would be induced in the windings. Serious damage to the equipment and possibly the death of personnel could result.

b. Use a multimeter set on the RX1 scale and test between terminals A1 and A2, B1 and B2, and C1 and C2. Continuity should be shown in all three tests.

c. Now, test between terminal A1 and B1, between A1 and C1, and between B1 and C1. There should be no continuity indicated in any of these three tests.

d. Connect the multimeter, in turn, across the terminals of each resistor and measure the resistance. The resistance should measure within one percent above or below 305 ohms.

If test shows resistors are defective, replace them. Refer to paragraph 7-5 for removal and installation of the resistors. If the malfunction is not caused by faulty resistors, go on to Step 3.

Step 3. Determine if the voltage regulator is defective by performing voltage regulator on-equipment test as described below.

a. Put output selector switch to desired output setting (fig. 2-4) and disconnect the load cables.

b. Start the generator set (fig. 2-7 or fig. 2-8). Place the circuit breaker to the ON position and check output selector switch to indicate load terminals where output voltage is applied.

c. Check set voltmeter for correct setting. Using a multimeter, check load terminals to verify reading on set voltmeter. If voltage is low and the variable resistor on the control panel will not correct the deficiency, check exciter voltage across terminals 20 and 21 of the voltage regulator terminal board. This voltage will vary but should be about 30 volts. If voltage at terminals 20 and 21 of the voltage regulator terminal board fails to meet specifications, the voltage regulator is defective and should be replaced.

d. Using a multimeter as a check against the set voltmeter, test the output terminals of the generator set against all position settings of the voltage switch.

e. Stop the generator set and connect the load cables.

f. Repeat steps 2 and 3 above.

If the regulator is faulty replace it. Refer to figure 7-3 for voltage regulator with PN 13211E6975 (97403) or 13212E8950 (97403) and to figure 7-4 for voltage regulator PN 13219E0883 (97403). Refer to paragraph 7-6 for removal and installation instructions. If faulty voltage regulator is not the cause of the malfunction, go on to Step 4.

Table 5-1. DS and GS Troubleshooting (Cont'd)

| Malfunction | Test or Inspection | Corrective Action | | | | |
|-----------------------------|-----------------------------------|--|----------------------------|----------|-----------------------------|------------|
| Step 4. | Test the generator as follows: | <p>a. General. On-equipment electrical test procedures may provide a basis for determining the necessity and extent of generator repair. The resistance values and tolerances contained in this paragraph should be used only as a general guide. Take into consideration the test instrument used, test lead resistance, and the ambient temperature at the time of the test. If more precise measurements are required, use an instrument such as a Kelvin Balance or a Wheatstone Bridge and make comparative measurements between the suspected component and like item that is known to be good.</p> <p>b. Stator.</p> <ol style="list-style-type: none"> (1) Disconnect the plug connector (P2) at the rear of the control box. (2) Use a multimeter that has been set on the RX1 scale and test for continuity between plug pins A and B, D and E, and C and F. If continuity is not indicated (full deflection) on any of the tests, remove the plug at the generator and repeat the tests at the generator. If again, continuity is not shown, the stator is defective and must be replaced. Refer to para. 7-14. <p>c. Rotor.</p> <ol style="list-style-type: none"> (1) Remove the blower cover and fan (para 6-2 or 6-3). (2) Use a multimeter that has been set on the RX1 scale and test between the rotor field windings terminal and the case of the rotor. If the resistance is not within five percent above or below the following values, the rotor must be removed for further testing (TM 5-764): <table data-bbox="522 961 1188 1024"> <tr> <td>Model MEP 01 7A (60 Hertz)</td> <td>8.8 ohms</td> </tr> <tr> <td>Model MEP4-022A (400 Hertz)</td> <td>0.615 ohms</td> </tr> </table> <p>d. Exciter Field Windings.</p> <ol style="list-style-type: none"> (1) Disconnect the plug connector (PI) at the rear of the control box. (2) Use a multimeter that has been set on the RX1 scale and test for continuity between plug pins G and H. If the resistance is not within five percent above or below 54.4 ohms, the windings are defective and must be replaced. Refer to para 7-14. | Model MEP 01 7A (60 Hertz) | 8.8 ohms | Model MEP4-022A (400 Hertz) | 0.615 ohms |
| Model MEP 01 7A (60 Hertz) | 8.8 ohms | | | | | |
| Model MEP4-022A (400 Hertz) | 0.615 ohms | | | | | |
| 2. | GENERATOR VOLTAGE TOO HIGH | <p>Step 1. Test the voltage regulator as follows:</p> <ol style="list-style-type: none"> a. Put output selector switch to desired output setting (fig. 2-4) and disconnect the load cables. b. Start the generator set (fig. 2-7 or fig. 2-8). Place the circuit breaker to the ON position and check output selector switch to indicate load terminals where output voltage is applied. c. Check set voltmeter for correct setting. Using a multimeter, check load terminals to verify reading on set voltmeter. If voltage is low and the variable resistor on the control panel will not correct the deficiency, check exciter voltage across terminals 20 and 21 of the voltage regulator terminal board. This voltage will vary but should be about 30 volts. If voltage at terminals 20 and 21 of the voltage regulator terminal board fails to meet specifications, the voltage regulator is defective and should be replaced. d. Using a multimeter as a check against the set voltmeter, test the output terminals of the generator set against all position settings of the voltage selector switch. e. Stop the generator set and connect the load cables. f. Repeat steps 2 and 3 above. If the voltage regulator does not pass the test, replace it. Refer to figure 7-3 for voltage regulator PN 13211E6975(97403) or 13212ES950(97403) or to figure 7-4 for voltage regulator PN 13219E0883(97403) and to paragraph 7-6 for removal and installation. If the tests show the regulator is not damaged, go on to step 2. | | | | |

Table 5-1. DS and GS Troubleshooting (Cont 'd)

Malfunction

Test or Inspection

Corrective Action

Step 2.

Test the generator as follows:

a. General. On-equipment electrical test procedure may provide a basis for determining the necessity and extent of generator repair. The resistance values and tolerances contained in this paragraph should be used only as a general guide. Take into consideration the test instrument used, test lead resistance, and the ambient temperature at the time of the test. If more precise measurements are required, use an instrument such as a Kelvin Balance or a Whetstone Bridge and make comparative measurements between the suspected component and a like item that is known to be good.

b. Stator.

(1) Disconnect the plug connector (P1) at the rear of the control box.

(2) Use a multimeter that has been set on the RX1 scale and test for continuity between plug pins A and B, D and E, and C and F. If continuity is not indicated (full deflection) on any of the tests, remove the plug at the generator and repeat the tests at the generator. If, again, continuity is not shown, the stator is defective and must be replaced.

c. Rotor.

(1) Remove the blower cover and fan (para. 6-2 or 6-3).

(2) Use a multimeter that has been set on the RX1 scale and test between the rotor field windings terminal and the case of the rotor. If the resistance is not within five percent above or below the following values, the rotor must be removed for further testing (TM 5-764):

| | |
|----------------------------|------------|
| Model MEP-017A (60 Hertz) | 8.8 ohms |
| Model MEP-022A (400 Hertz) | 0.615 ohms |

d. Exciter Field Windings.

(1) Disconnect the plug connector (P1) at the rear of the control box.

(2) Use Multimeter that has been set on the RX1 scale and test for continuity between plug pins G and H. If the resistance is not within five percent above or below 54-4 ohms, the windings are defective and must be replaced. Refer to para. 7-14.

3. GENERATOR FREQUENCY FLUCTUATES OR DROPS UNDER LOAD

Check frequency converter for breaks or cracks. Check for burned, broken, or worn wiring. Test the frequency meter with a multimeter, refer to paragraph 4-16.

If the meter does not pass the tests and inspections given above, replace it. Refer to paragraph 7-2 for instructions.

4. AC VOLTMETER FAILS TO INDICATE VOLTAGE OR CURRENT INDICATOR METER FAILS TO INDICATE CURRENT

Step 1.

Perform the following tests:

a. Tag and disconnect all output selector switch leads.

b. Use a multimeter set on the RX1 scale and test the switch for continuity as outlined in **c** through **f** below.

c. Turn the switch to the "120/208v, 3 phase" position. In this position there should be continuity indicated between terminals 7 and 8, 9 and 10, 2 and 6, and 13 and 14 of the switch.

d. Turn the switch to the "120v, 3 phase" position. Continuity should be indicated between terminals 8 and 9, 2 and 4, 5 and 6, and 13 and 15.

e. Position the switch in the "120v, 1 phase" position. Continuity should be indicated between terminals 8 and 10, 2 and 4, 1 and 3, 5 and 6, and 11 and 13 of the switch.

f. Turn the switch to the 240v, 1 phase position. Continuity should be indicated between terminals 8 and 10, 2 and 6, 1 and 3, and 12 and 13 of the switch.

If the switch does not pass the test above, replace it. Refer to figure 5-1 for removal and installation. If the switch passes the above test, go on to Step 2.

Table 5-1. DS and GS Troubleshooting (Cont'd)

Malfunction

Test or Inspection

Corrective Action

Step 2.

Test the current transformer as follows:

- a. Disconnect the current transformer leads and remove the three resistors.

WARNING

Never disconnect the leads of a current transformer or at a meter connected to the transformer, when the equipment is energized. The three resistors used with this equipment are connected across the secondary windings of the current transformer and they ordinarily prevent an open circuit condition. But, if a resistor were to fail and then the secondary was to be open circuited by disconnecting its load (the meter), extremely high voltages would be induced in the windings. Serious damage to the equipment and possibly the death of personnel could result.

b. Use a multimeter set on the RX1 scale and test between transformer terminals A1 and A2, B1 and B2, and C1 and C2. Continuity should be shown all three tests.

c. Now, test between transformer terminal A1 and B1, between A1 and C1, and between B1 and C1. There should be no continuity indicated in any of these three tests.

d. Connect the meter, in turn, across the terminals of each resistor and measure the resistance. The resistance should measure within one percent above or below 305 ohms.

If the transformer does not pass the above test, replace it. Refer to paragraph 7-5 for removal and installation.

5. FREQUENCY METER FAILS TO INDICATE FREQUENCY

Inspect for a cracked or broken meter. Check for broken, burned, or worn wire. Test the frequency converter to determine its condition as follows:

a. Model MEP-017A.

(1) Apply AC input of 120 volts, 60 hertz current across terminals marked "L".

(2) With panel (M3) connected to output side meter reading should indicate 60 hertz + 0.5 hertz.

(3) For test with panel meter disconnected, direct output current of the converter shall be 100 microampere + 10 microampere with 1100 ohm load across positive and negative terminals.

b. Model MEP-022A. With generator set operating at 3428 rpm, remove screw in the face of the frequency converter and adjust the potentiometer for a reading of 400 HZ on the frequency meter. If proper reading is not obtained, proceed as follows:

(1) Disconnect the lead from the Positive (+) and negative (-) terminals on the frequency meter.

(2) Attach a multimeter with the scale set to read at least 200 microampere, to the + and terminals on the frequency meter.

(3) Operate generator set at 3428 rpm and turn adjusting screw to obtain a 100 microamperes on the multi-meter scale.

(4) If reading is accomplished, the frequency meter on the control panel is faulty and must be replaced.

(5) If reading of 100 microamperes cannot be obtained, disconnect the wire leads from the two L terminals on the frequency converter. Test the wire leads. If no defect is discovered, replace frequency converter and operate generator set. Turn adjusting screw to obtain 400 HZ reading.

If frequency meter does not pass the above test, replace it. Refer to paragraph 7-2 and replace the meter to the applicable model generator set.

Table 5-1. DS and GS Troubleshooting (Cont'd)

| Malfunction | Test or Inspection | Corrective Action |
|-------------|--------------------|-------------------|
|-------------|--------------------|-------------------|

6. GENERATOR FREQUENCY FLUCTUATES OR DROPS UNDER LOAD

Test the frequency converter to determine its condition. Test as follows:

a. Model MEP-017A.

(1) apply AC input of 120 volts, 60 hertz current across terminals marked "L".

(2) With panel meter (M3) connected to output side meter reading should indicate 60 hertz + 0.5 hertz.

(3) For test with panel meter disconnected, direct output current of the converter shall be 100 microampere + 10 microampere with 1100 ohm load across positive and negative terminals.

b. Model MEP-022A. With generator set operating at 3428 rpm, remove screw in the face of the frequency converter and adjust the potentiometer for a reading of 400 HZ on the frequency meter. If proper reading is not obtained, proceed as follows:

(1) Disconnect the lead from the positive (+) and negative (-) terminals on the frequency meter.

(2) Attach a multimeter with the scale set to read at least 200 microampere. to the + and terminals on the frequency converter.

(3) Operate generator set at 3428 rpm and turn adjusting screw to obtain a 100 microampere reading on the multi meter scale.

(4) If reading is accomplished. the frequency meter on the control panel is faulty and must be replaced.

(5) If reading of 100 microamperes cannot be obtained. disconnect the wire leads from the two L terminals on the frequency converter. Test the wire leads. If no defect is discovered, replace frequency converter and operate generator set. Turn adjusting screw to obtain 400 HZ meter reading.

If frequency meter does not pass the above test, replace it. Refer to paragraph 7-2 and replace the meter in the applicable model generator set.

7. GENERATOR NOISY

Step 1. Remove the generator, paragraph 6-2 or 6-3. Disassemble the generator, paragraphs 7-13 and 7-14, to the extent necessary to inspect the bearing. Inspect bearing for leakage, looseness, and smoothness when turned. Inspect for evidence of wear.

If the bearing does not pass the inspection above, replace it. Assemble the generator, paragraphs 7-13 and 7-14. Reinstall the generator, paragraph 6-2 or 6-3. If the bearing passes the above inspection, go on to Step 2.

Step 2. Remove the generator, paragraph 6-2 or 6-3. Disassemble the generator, paragraph 7-13 and 7-14, to the extent necessary to inspect the fan and rotor adapter. Inspect for looseness, cracks, wear, and other physical damage.

If the fan and rotor adapter does not pass the above inspection, replace them. Reassemble the generator, paragraph 7-13 and 7-14. Reinstall the generator, paragraph 6-2 or 6-3.

8. GENERATOR OVERHEATS

Step 1. Inspect the fan for cracks, breaks, insufficient mounting, and looseness.

If fan condition does not pass the above inspection, replace it. Refer to paragraph 6-2 or 6-3 for removal and installation. If fan passes the inspection, go on to Step 2.

Step 2. Test the stator as follows:

a. Disconnect the plug connector (P1) at the rear of the control box.

b. Use a multimeter that has been set on the RX1 scale and test for continuity between plug pins A and B, D and E, and C and F. If continuity is not indicated (full deflection) on any of the tests, remove the plug at the generator and repeat the tests at the generator.

Table 5-1. DS and GS Troubleshooting (Cont'd)

Malfunction

Test or Inspection

Corrective Action

If continuity is shown, the cable is defective and must be replaced. If continuity is not shown, the stator is defective and must be replaced. Remove the generator, paragraph 6-2 or 6-3. Disassemble the generator, paragraphs 7-13 and 7-14, to the extent necessary to replace the stator. If the stator passes the above test, go on to Step 3.

Step 3.

Test the rotor as follows:

a. Remove the blower cover and fan, para. 6-2 or 6-3.

b. Use a multimeter that has been set on the RX1 scale and test between the rotor field windings terminal and the case of the rotor. If the resistance is not within five percent above or below the following values, the rotor must be removed for further testing (TM 5-764):

Model MEP-017A (60 Hertz) 8.8 ohms

Model MEP-022A (400 Hertz) 0.615 ohms

If the rotor does not pass the above test, replace it. Refer to paragraph 6-2 or 6-3 and remove the generator. Refer to paragraph 7-13 and 7-14, disassemble the generator to the extent necessary to replace the rotor.

Section III. GENERAL MAINTENANCE

5-5. General

Refer to Chapters 2 and 3 for operator preventive maintenance checks and services and service the generator set.

5-6. General Disassembly Procedures

a. Components to be repaired shall be disassembled to the extent required for complete serviceability.

b. Serviceable, precision, matched or mated parts shall be marked, handled and stored to preclude damage and to insure reassembly and installation in their matched and mated positions in the same assembly or component.

5-7. General Repair and/or Replacement Criteria

a. In-process inspection shall be performed on each assembly, subassembly and component parts being repaired to insure strict adherence to criteria established by this manual.

b. Welding shall assure complete fusion and penetration and be in compliance with specifications and standards referenced herein.

5-8. General Reassembly Procedures

a. General precautions shall be adhered to during reassembly to insure that all internal parts have been properly installed and necessary lence checks performed.

b. upon completion of reassembly, generator set shall be lubricated in accordance with Lubrication Order. Refer to DA-PAM-310-4 for current listing.

CHAPTER 6

REMOVAL AND INSTALLATION OF MAJOR COMPONENTS

6-1. Control Box

a. Removal. Refer to figure 6-1 and the following instructions to remove the control box.

- (1) Disconnect electrical cables from the control box.
- (2) Remove the ground strap from the control box.
- (3) Remove the screws and washers which secure the control box to the generator housing.

(4) Remove the screws and washers that secures the control box to the bottom resilient mounts and remove the control box.

b. Installation.

- (1) Position the control box in place on the resilient mounts and secure with washers and screws.
- (2) Secure control box to the generator housing with washers and screws.
- (3) Install ground strap.
- (4) Reconnect electrical cables.

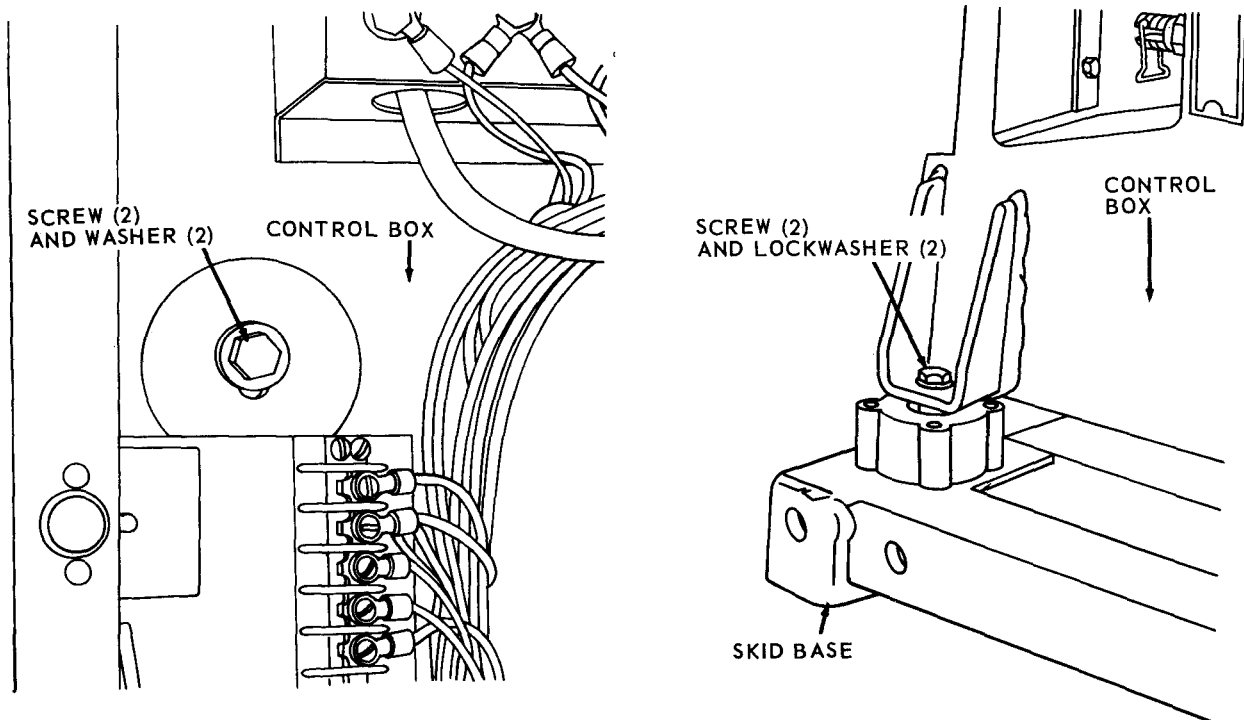

TS 6115-332-14/6-1

Figure 6-1. Control box, removal and installation.

6-2. Generator (Model MEP-017A)

a. Removal.

- (1) Lift the locking handle (fig. 3-4) and remove the fuel can adapter from the fuel can.
- (2) Lift clamp and loosen the strap securing the fuel can in the fuel can bracket sufficiently to allow for removal of the fuel can.
- (3) Disconnect the battery cables (fig. 4-22).
- (4) Remove nuts and washers which secure the upper battery frame and remove frame and hook bolts.
- (5) Remove battery from battery frame.
- (6) Remove the nuts, lockwashers and screws (fig. 4-33) that secure the guard frame to the skid base.
- (7) Remove the screw and lockwasher that secures the guard frame to the flywheel housing and remove guard frame from the generator.
- (8) Remove the nuts, lockwashers and screws (fig. 4-31) which secure the toolbox to the toolbox bracket and remove the toolbox.
- (9) Remove the nuts, washers and screws (fig. 4-30) which secure the resilient mounts to the control box bracket.
- (10) Remove the resilient mounts.
- (11) Remove the screws and lockwashers (fig. 4-32, View A) that secure the control box bracket to the side of the generator housing.
- (12) Remove the lifting eye (fig. 4-32, View B) and screw and screw and lockwasher securing the control box bracket to the top of the generator housing.
- (13) Remove the control box bracket.
- (14) Disconnect the electrical cables from the control box.
- (15) Remove the ground strap.
- (16) Remove the screws and washers (fig. 6-1) which secure the control box to the generator housing.
- (17) Remove the screws and washers that secure the control box to the bottom resilient mounts and remove the control box.
- (18) Disconnect electrical cable from the generator housing (fig. 6-2).
- (19) Remove screws and washers securing the fan cover (fig. 4-22) to the generator housing and remove the fan cover.

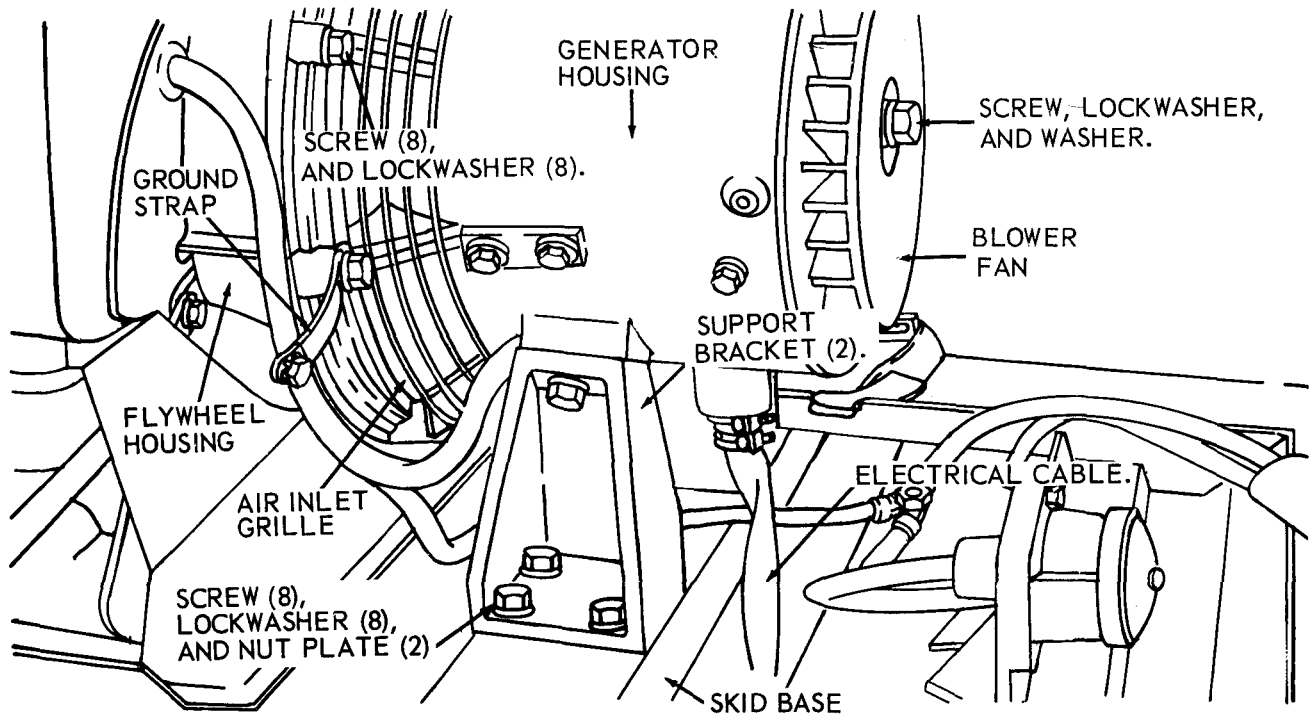

A. GENERATOR HOUSING

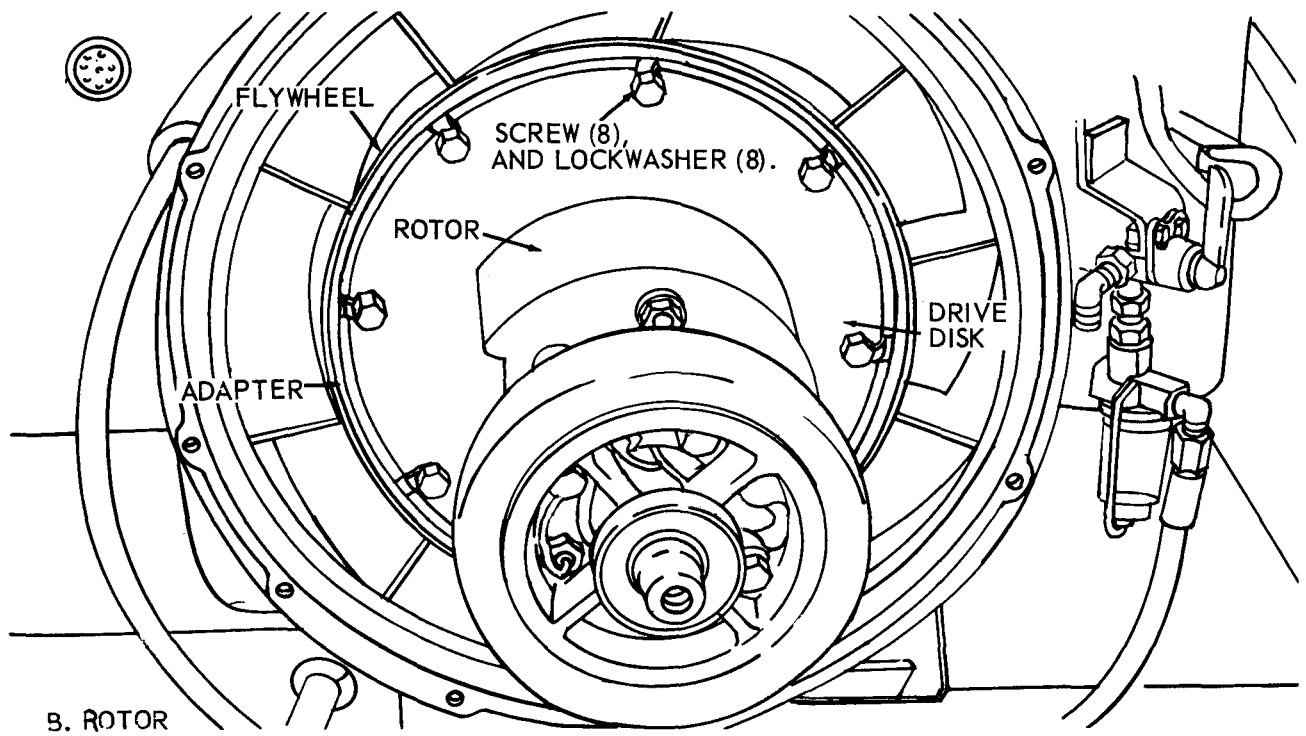

B. ROTOR

TS 6115-332-14 6-2

Figure 6-2. Generator, removal and installation (Model MEP-017A).

(20) Remove screw and washers securing the blower fan and remove blower fan.

(21) Remove the ground strap.

(22) Remove screws and washers which secure the generator housing to the support brackets.

NOTE

Block up engine with suitable cribbing before removing screws and lockwashers securing the generator to the flywheel housing. Attach a suitable sling around the generator housing and with a hoist raise housing until a slight tension is felt.

(23) Remove the screws and lockwashers securing the generator to the flywheel housing.

(24) Shale generator housing to the rear and remove the housing. Remove air inlet grille from housing.

(25) Straighten tang on locks and remove the screws and locks securing the drive disk to the adapter and remove drive disk and rotor.

(26) Straighten tang on locks and remove screws and locks securing the adapter to the flywheel and remove adapter from the flywheel.

b. Installation.

(1) Position adapter in place on the flywheel and secure with locks and screws.

NOTE

Bend tang up over screws.

(2) Position the drive disk in place on the adapter and secure with locks and screws.

NOTE

Bend tang up over screws.

(3) Place air inlet grille around the generator housing and secure housing and grille to the flywheel housing with lockwashers and screws.

NOTE

Torque screws to 13 to 16 FT. LB. (1.80 to 2.21 kgm).

(4) Install the ground strap.

(5) Position blower fan in place and secure with washers and screws.

NOTE

Torque screws to 14 to 16 FT. LB. (1.94 to 2.21 kgm).

(6) Install the fan cover to the generator housing with washers and screws.

(7) Reconnect electrical cable to generator.

(8) Position the control box in place on the bottom resilient mounts and secure with washers and screws.

(9) Secure the control box to the generator housing with washers and screws.

(10) Install ground strap.

(11) Reconnect electrical cables to control box.

(12) Position the control box bracket in place and secure to the top of the generator housing with washers and screws.

(13) Install lifting eye.

(14) Secure bracket to side of the generator housing with washers and screws.

(15) Install resilient mounts to control box bracket with screws, washers, and nuts.

(16) Place toolbox in position and secure with screws, lockwashers, and nuts.

(17) Place guard frame over generator set and secure to the flywheel housing with screws, lockwashers, and nuts.

(18) Secure guard frame to the skid base using screws, lockwashers, and nuts.

(19) Place battery in battery frame and position hook bolt in place.

(20) Install upper battery frame with washers and nuts.

(21) Reconnect battery cables.

(22) Place fuel can in fuel can bracket and secure with strap. Depress clamp to secure.

(23) Place fuel can adapter in fuel can and secure by depressing the locking handle.

6-3. Generator (Model MEP-022A)

a. Removal.

(1) Lift the locking handle (fig. 3-4) and remove the fuel can adapter from the fuel can.

(2) Lift clamp and loosen the strap securing the fuel can in the fuel can bracket sufficiently to allow for removal of the fuel can.

(3) Disconnect the battery cables (fig. 4-22).

(4) Remove nuts and washers which secure the upper battery frame and remove frame and hook bolts.

(5) Remove battery from battery frame.

(6) Remove the nuts, lockwashers and screws (fig. 4-33) that secure the guard frame to the skid base.

(7) Remove the screw and lockwasher that secures the guard frame to the flywheel housing and remove guard frame from the generator.

(8) Remove the nuts, lockwashers and screws (fig. 4-31) which secure the toolbox to the toolbox bracket and remove the toolbox.

(9) Remove the nuts, washers and screws (fig. 4-30) which secure the resilient mounts to the control box bracket.

(10) Remove the resilient mounts.

(11) Remove the screws and lockwashers (fig. 4-32, View A) that secure the control box bracket to the side of the generator housing.

(12) Remove the lifting eye (fig. 4-32, View B) and screw and lockwasher securing the control box bracket to the top of the generator housing.

(13) Remove the control box bracket.

(14) Disconnect the electrical cables from the control box.

(15) Remove the ground strap.

(16) Remove the screws and washers (fig. 6-1) which secure the control box to the generator housing.

(17) Remove the screws and washers that secure the control box to the bottom resilient mounts and remove the control box.

(18) Disconnect electrical cable from the generator housing (fig. 6-2).

(19) Remove screws and washers securing the fan cover (fig. 4-22) to the generator housing and remove the fan cover.

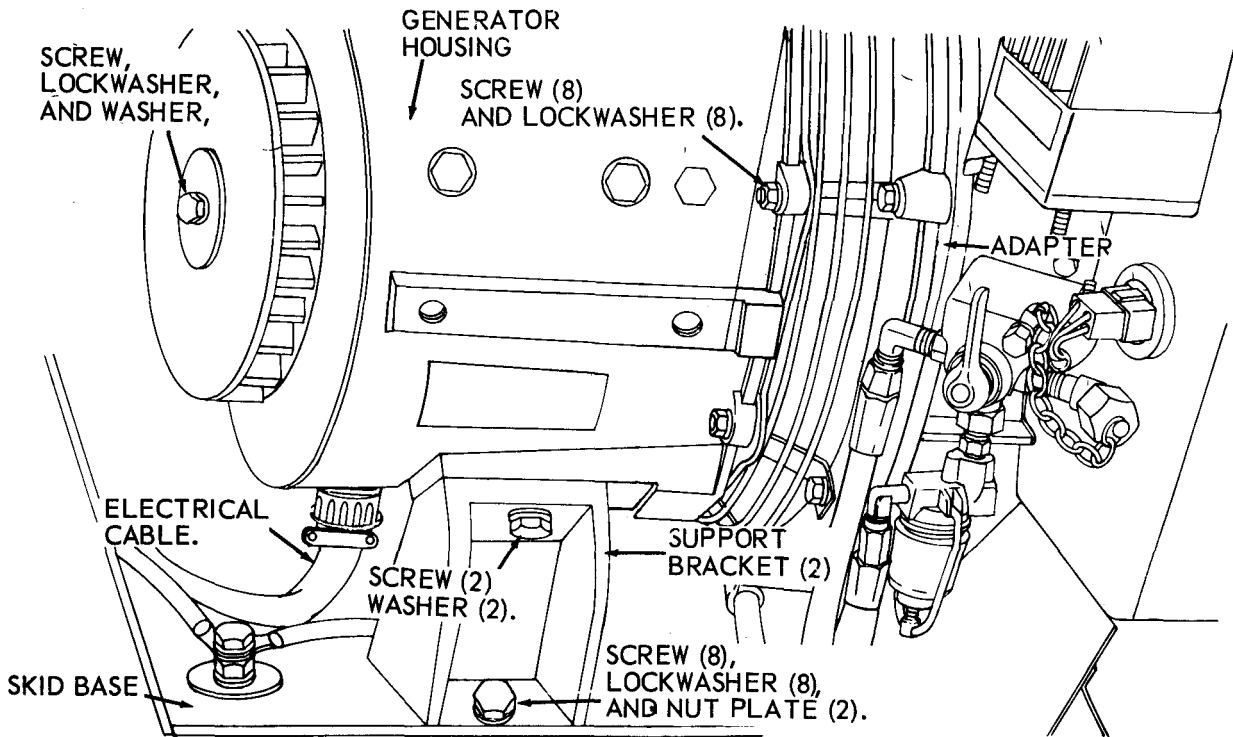

A. GENERATOR HOUSING

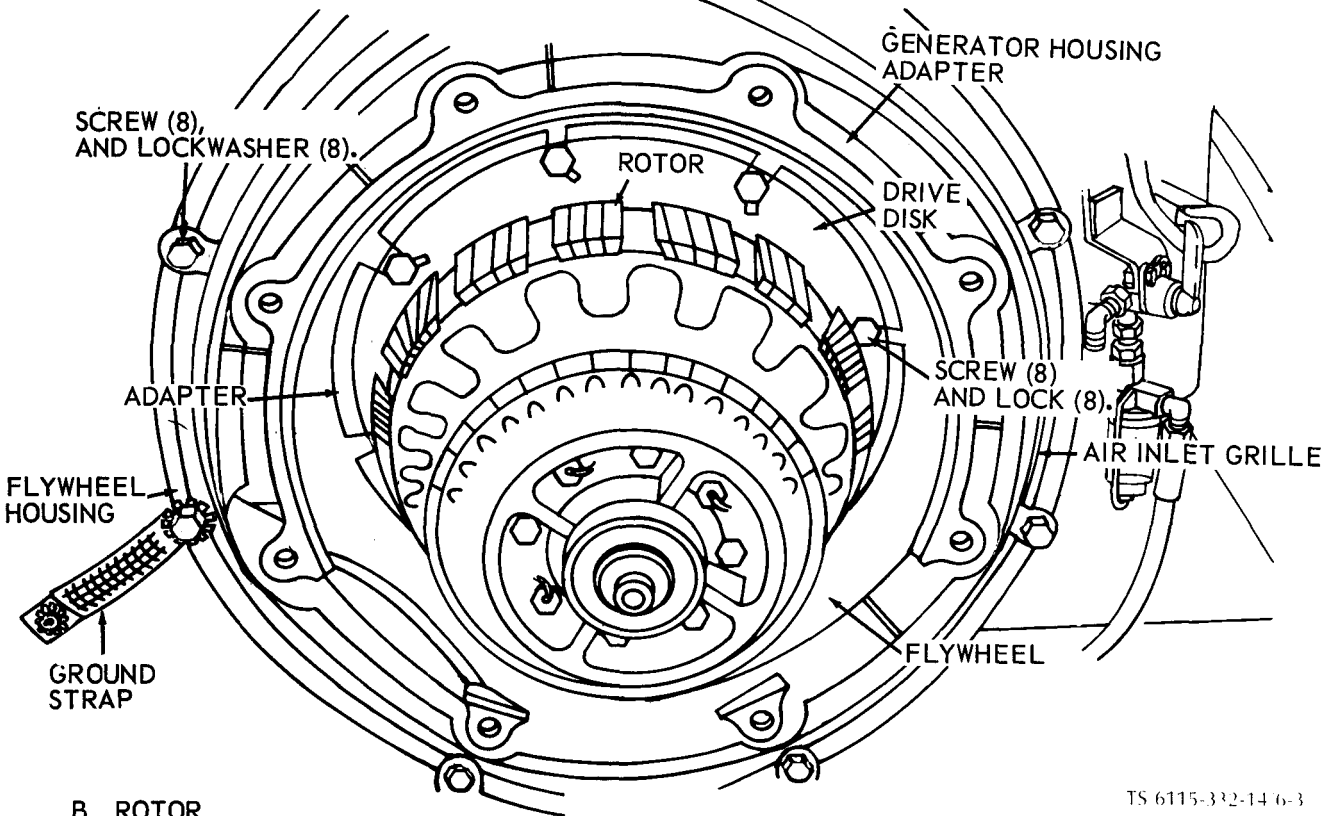

B. ROTOR

TS 6115-332-14 6-3

Figure 6-3. Generator, removal and installation (Model MEP-022A).

(20) Remove screw and washers securing the blower fan and remove blower fan.

(21) Remove the ground strap.

(22) Remove screws and washers which secure the generator housing to the support brackets.

NOTE

Block up engine with suitable cribbing before removing screws and lockwashers securing the generator to the flywheel housing. Attach a suitable sling around the generator housing and with a hoist housing until a slight tension is felt.

(23) Remove the screws and lockwashers securing the generator to the flywheel housing.

(24) Slide generator housing to the rear and remove the housing. Remove air inlet grille from housing.

(25) Straighten tang on locks and remove the screws and locks securing the drive disk to the adapter and remove drive disk and rotor.

(26) Straighten tang on locks and remove screws and locks securing the adapter to the flywheel and remove adapter from the flywheel.

b. Installation.

(1) Position adapter in place on the flywheel and secure with lock and screws.

NOTE

Bend tang up over screws.

(2) Position the drive disk in place on the adapter and secure with locks and screws.

NOTE

Bend tang up over screws.

(3) Place air inlet grille around the generator housing and secure housing and grille to the flywheel housing with lockwashers and screws.

NOTE

Torque screws to 13 to 16 FT. LB. (1.80 to 2.21 kgm).

(4) Install the ground strap.

(5) Position blower fan in place and secure with washers and screws.

NOTE

Torque screw to 14 to 16 FT. LB. (1.94 to 2.21 kgm).

(6) Install the fan cover to the generator housing with washers and screws.

(7) Reconnect electrical cable to generator.

(8) Position the control box in place on the bottom resilient mounts and secure with washers and screws.

(9) Secure the control box to the generator housing with washers and screws.

(10) Install ground strap.

(11) Reconnect electrical cables to control box.

(12) Position the control box bracket in place and secure to the top of the generator housing with washers and screws.

(13) Install lifting eye.

(14) Secure bracket to side of the generator housing with washers and screws.

(15) Install resilient mounts to control box bracket with screws, washers, and nuts.

(16) Place toolbox in position and secure with screws, lockwashers, and nuts.

(17) Place guard frame over generator set and secure to the flywheel housing with screws, lockwashers, and nuts.

(18) Secure guard frame to the skid base using screws, lockwashers, and nuts.

(19) Place battery in battery frame and position hook bolt in place.

(20) Install upper battery frame with washers and nuts.

(21) Reconnect battery cables.

(22) Place fuel can in fuel can bracket and secure with strap. Depress clamp to secure.

(23) Place fuel can adapter in fuel can and secure by depressing the locking handle.

6-4. Engine

a. Removal.

(1) Lift the locking handle (fig. 3-4) and remove the fuel can adapter from the fuel can.

(2) Lift clamp and loosen the strap securing the fuel can in the fuel can bracket sufficiently to allow for removal of the fuel can.

(3) Disconnect the battery cables (fig. 4-22).

(4) Remove nuts and washers which secure the upper battery frame and remove frame and hook bolts.

(5) Remove battery from battery frame.

(6) Remove the nuts, lockwashers and screws (fig. 4-33) that secure the guard frame to the skid base.

(7) Remove the screw and lockwasher that secures the guard frame to the flywheel housing and remove guard frame from the generator.

(8) Remove the nuts, lockwashers and screws (fig. 4-31) which secure the toolbox to the toolbox bracket and remove the toolbox.

(9) Remove the nuts, washers and screws (fig. 4-30) which secure the resilient mounts to the control box bracket.

- (10) Remove the resilient mounts.
- (11) Remove the screws and lockwashers (fig. 4-32, View A) that secure the control box bracket to the side of the generator housing.
- (12) Remove the lifting eye (fig. 4-32, View B) and screw and lock-washer securing the control box bracket to the top of the generator housing.
- (13) Remove the control box bracket.
- (14) Disconnect the electrical cables from the control box.
- (15) Remove the ground strap.
- (16) Remove the screws and washers (fig. 6-1) which secure the control box to the generator housing.
- (17) Remove the screws and washers that secure the control box to the bottom resilient mounts and remove the control box.
- (18) Disconnect electrical cable from the generator housing (fig. 6-2).
- (19) Remove screws and washers securing the fan cover (fig. 4-22) to the generator housing and remove the fan cover.
- (20) Remove screw and washers securing the blower fan and remove blower fan.

- (21) Remove the ground strap.
- (22) Remove screws and washers which secure the generator housing to the support brackets.

NOTE

Block up engine with suitable cribbing before removing screws and lockwashers securing the generator to the flywheel housing. Attach a suitable sling around the generator housing and with a hoist raise housing until a slight tension is felt.

- (23) Remove the screws and lockwashers securing the generator to the flywheel housing.
- (24) Slide generator housing to the rear and remove the housing. Remove air inlet grille from housing.
- (25) Straighten tang on locks and remove the screws and locks securing the drive disk to the adapter and remove drive disk and rotor.
- (26) Straighten tang on locks and remove screws and locks securing the adapter to the flywheel and remove adapter from the flywheel.
- (27) Disconnect the fuel hoses (fig. 6-4) and starter cables (fig. 6-5).
- (28) Drain oil from engine and remove oil drain cock prior to the removal of the engine.

NOTE: DISCONNECT FUEL HOSES AT CARBURETOR
AND FUEL CAN ADAPTER TO REMOVE HOSES.

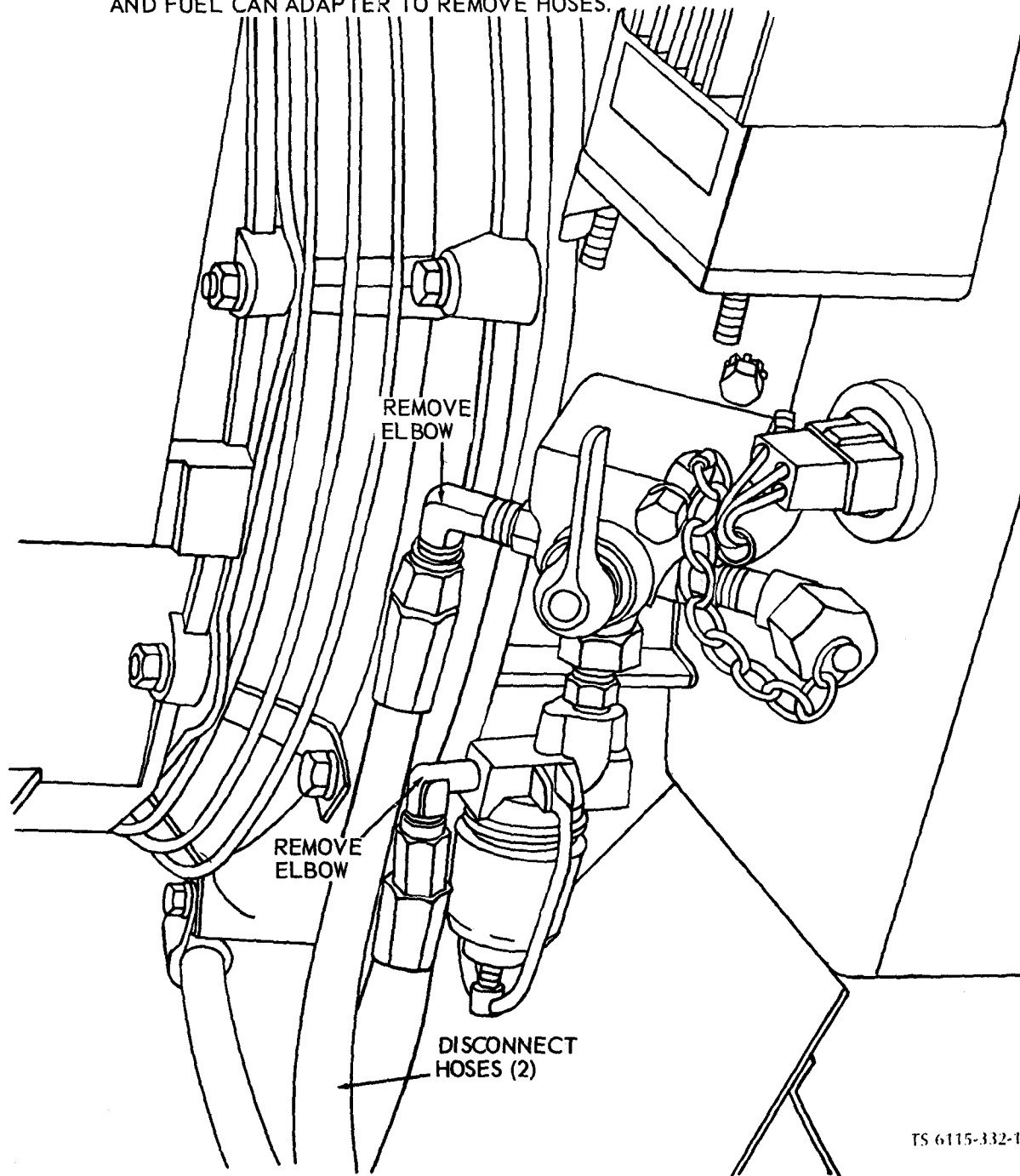

TS 6115-332-14.6-4

Figure 6-4. Fuel hoses, removal and installation.

TM 5-6115-332-14
P-8-614-14
TO 35C2-3-424-1

NOTE: DISCONNECT STARTER
CABLE AT STARTER AND
REMOVE GROMMET
FROM ENGINE SHROUD.

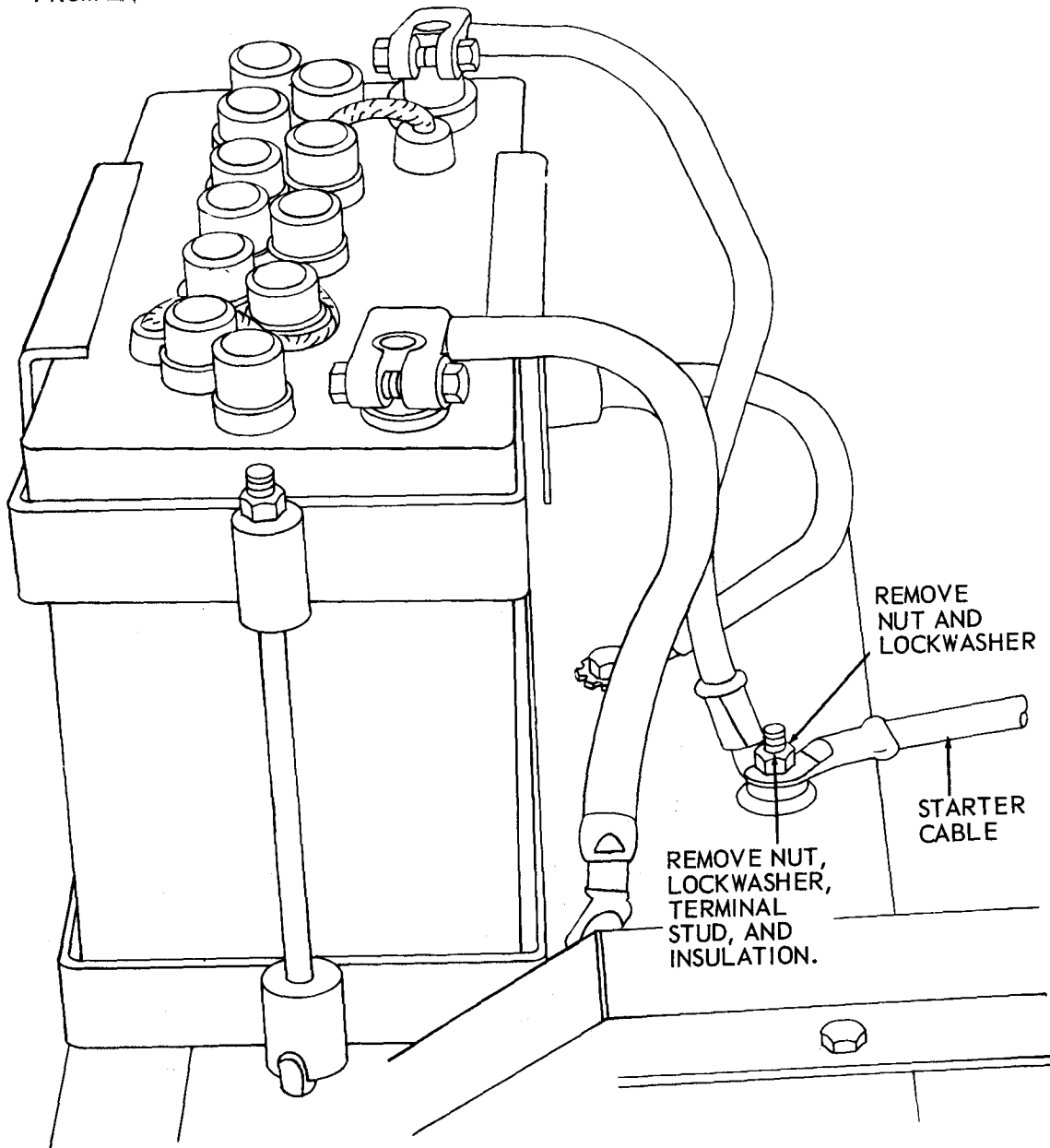

TS 6115-332-14 6-5

Figure 6-5. Starter cable, removal.

(29) Disconnect the engine control cable at the rear of the engine.

(30) Attach a sling to the engine lifting eye and with the aid of a suitable hoist, raise engine until a slight tension is felt.

(31) Remove the nut, lockwasher, flat washer and screw securing the engine to the engine support (fig. 6-6). Remove engine oil drain assembly and remove engine. Detach hoist.

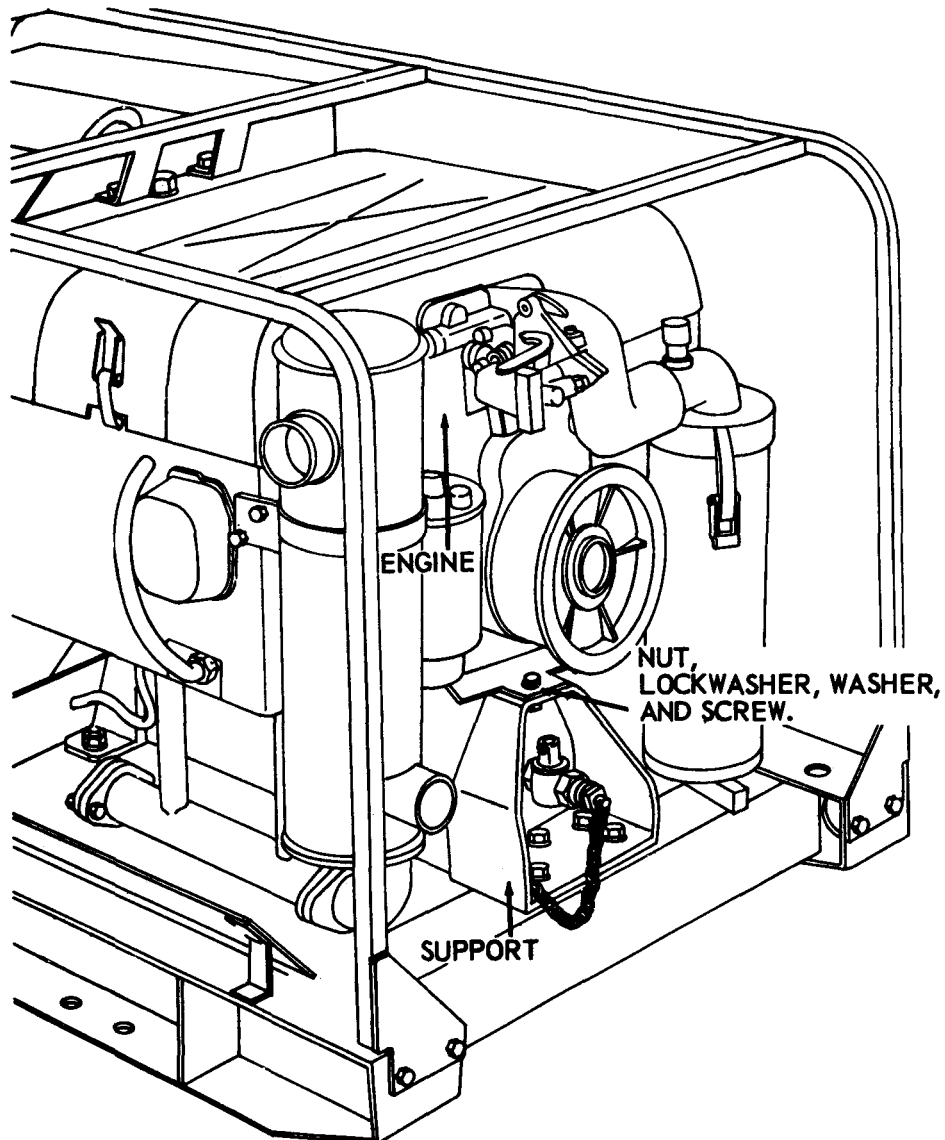

TS 6115-332-14/6-6

Figure 6-6. Engine, removal and installation.

b. Installation.

(1) Attach a sling to the engine lifting eye and with the aid of a suitable hoist, lower engine into position on mounting bracket. Secure with screw, flat washer, lockwasher and nut.

(2) Connect the engine control cable to the rear of the engine.

(3) Connect the fuel hoses and starter cables.

(4) Position adapter in place on the flywheel and secure with lock and screws.

NOTE

Bend tang up over screws.

(5) Position the drive disk in place on the adapter and secure with locks and screws.

NOTE

Bend tang up over screws.

(6) Place air inlet grille around the generator housing and secure housing and grille to the flywheel housing with lockwashers and screws.

NOTE

Torque screws to 13 to 16 FT. LB. (1.80 to 2.21 kgm).

(7) Install the ground strap.

(8) Position blower fan in place and secure with washers and screw.

NOTE

Torque screws to 14 to 16 FT. LB. (1.94 to 2.21 kgm).

(9) Install the fan cover to the generator housing with washers and screws.

(10) Reconnect electrical cable to generator.

(11) Position the control box in place on the bottom resilient mounts and secure with washers and screws.

(12) Secure the control box to the generator housing with washers and screws.

(13) Install ground strap.

(14) Reconnect electrical cables to control box.

(15) Position the control box bracket in place and secure to the top of the generator housing with washers and screws.

(16) Install lifting eye.

(17) Secure bracket to side of the generator housing with washers and screws.

(18) Install resilient mounts to control box bracket with screws, washers, and nuts.

(19) Place toolbox in position and secure with screws, lockwashers, and nuts.

(20) Place guard frame over generator set and secure to the flywheel housing with screw, lockwashers, and nuts.

(21) Secure guard frame to the skid base using screws, lockwashers, and nuts.

(22) Place battery in battery frame and position hook bolt in place.

(23) Install upper battery frame with washers and nuts.

(24) Install battery terminal covers on both battery terminals. Reconnect battery cables.

(25) Place fuel can in fuel can bracket and secure with strap. Depress clamp to secure.

(26) Place fuel can adapter in fuel can and secure by depressing the locking handle.

(27) Ensure replacement of drain cock. Add oil as required.

CHAPTER 7
MAINTENANCE OF THE GENERATOR SET

Section I. CONTROL BOX ASSEMBLY

7-1. General

This section covers direct support and general support maintenance of the control box and components. It includes the frequency converter, output selector switch, relay panel, field flash switch, current transformer and resistors, voltage regulator and wiring. All components are accessible either by lowering the upper hinged panel or by removal of the lower access cover. Test procedures are included when applicable.

CAUTION

When plug P1 is connected, many of the meters are still active and need only a path to ground to complete circuit.

7-2. Frequency Converter

a. General. The frequency converter is located near the center of the control box. It receives an ac signal of 120 volts from one of the generator coil groups and converts this signal voltage to a dc voltage that is proportionate to the frequency of the generator output. The frequency meter is fed this dc voltage and the meter indicates the output frequency in Hertz.

b. Testing. Test the frequency converter as follows:

(1) Model MEP-071A.

(a) Apply AC input of 120 volts, 60 hertz current across terminals marked "L".

(b) With panel (M3) connected to output side meter reading should indicate 60 hertz + 0.5 hertz.

(c) For test with panel meter discon-

nected, direct output current of the converter shall be 100 microamperes + 10 microamperes with 1100 ohm load across positive and negative terminals.

(2) Model MEP-022A. With generator set operating at 3428 rpm, remove screw in the face of the frequency converter, and adjust the potentiometer for a reading of 400 HZ on the frequency meter. If proper reading is not obtained, proceed as follows:

(a) Disconnect the lead from the positive (+) and negative (-) terminals on the frequency meter.

(b) Attach a multimeter with the scale set to read at least 200 microampere, to the + and - terminals on the frequency meter.

(c) Operate generator set at 3428 rpm and turn adjusting screw to obtain a 100 microampere on the multimeter scale.

(d) If reading is accomplished, the frequency meter on the control panel is faulty and must be replaced.

(e) If reading of 100 microampere cannot be obtained, disconnect the wire leads from the two L terminals on the frequency converter, Test the wire leads. If no defect is discovered, replace frequency converter and operate generator set. Turn adjusting screw to obtain 400 HZ reading. If frequency meter does not pass the above test, replace it. Refer to figure 5-1 and replace the meter to the applicable model generator set.

c. Removal. Refer to figure 7-1 and the following instructions to remove the frequency converter.

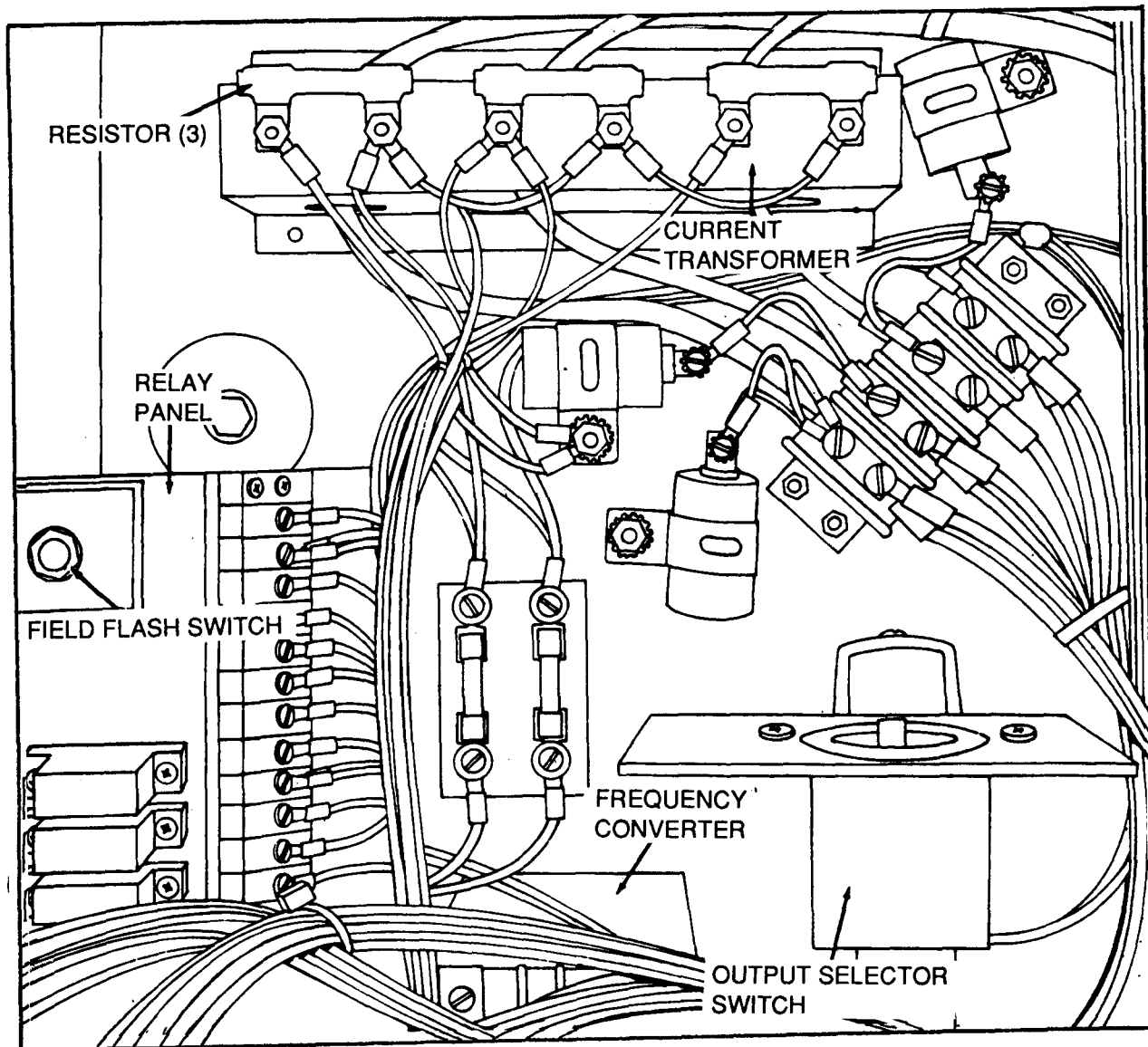

Figure 7-1. Control box components, removal and installation.

(1) Tag and disconnect all wiring from the frequency converter.

(2) Remove the screws and washers securing the frequency converter in the control box.

(3) Remove the frequency converter.

d. Cleaning and Inspection.

(1) Wipe the outer surface of the frequency converter clean using a clean lint-free cloth.

(2) Inspect frequency converter housing for cracks, burned areas, and for evidence of over-heating.

(3) Inspect contacts for corrosion, pitting, cracks, breaks or other damage.

e. Repair. Replace a defective frequency converter.

f. Installation.

(1) Position frequency converter in place on control box.

(2) Secure with washers and screws.

(3) Reconnect all wiring.

7-3. Output Selector Switch

a. Removal. Refer to Figure 7-1 and the following procedures to remove the output selector switch. On trailer mounted units, remove the control box assembly first using steps 1 through 5, then proceed with steps 6 through 9. On skid mounted units, start with step 6.

NOTE

Replacement switches may not have the terminals in the same location. To assure proper installation, follow the terminal diagram printed on the switch. Wire extension may be necessary to accommodate a replacement switch. The wires that need to be lengthened are: X7A10, X7C18, X6B10C, and X11A10A. Ensure materials needed to lengthen wires are on hand when ordering switch to reduce non-mission-capable (NMC) time.

- (1) Remove power cable from load terminals.
- (2) Disconnect cannon plugs from control box assembly.
- (3) Remove ground strap from control box assembly.
- (4) Remove control box assembly from generator frame.
- (5) Remove control box access cover and open control panel door.
- (6) Remove screws and washers securing output selector switch mounting brackets to control box assembly.
- (7) Tag and remove leads from output selector switch.
- (8) Remove output selector switch from control box assembly.
- (9) Remove top and bottom mounting brackets from output selector switch.

b. Cleaning. Clean the output selector switch using a clean lint free cloth to remove any foreign material.

c. Inspection.

- (1) Inspect the voltage selector switch to insure there is no binding or sticking in the various positions.
- (2) Inspect contacts for pitting, corrosion, evidence of burning or other damage.

WARNING

Replacement switches may not have the terminals in the same location. The terminal diagram on the switch must be followed. When facing the switch terminal diagram, the far terminals are the terminal rows farthest from the diagram and the near terminal rows are the closest. For proper connection of the switch, it may be necessary to lengthen four wires: X7A10, X7C18, X6B10C, and X11A10A.

d. Testing.

- (1) Refer to paragraph 7-3a and remove output selector switch.
- (2) Refer to switch terminal diagram located on switch and Table 7-1. Use multimeter set on RX 1 scale and test terminals A through L for continuity in all four positions. Readings should match those indicated in Table 7-1. Replace switch that does not pass this test.

e. Repair. Replace a defective output selector switch.

f. Installation.

- (1) Install top and bottom mounting brackets to output selector switch.
- (2) Position output selector switch in control box assembly.
- (3) Reconnect all leads on output selector switch.

- (4) Secure switch to control box assembly.
- (5) Install access cover on control box assembly.
- (6) Install control box assembly on generator frame.
- (7) Install ground straps.
- (8) Connect cannon plugs.
- (9) Install power cable.
- (10) Test generator set operation.

TABLE 7-1

| CONNECTIONS MADE BY S1 | | (X DENOTES CLOSED CONTACT SET) | | | | | | | | | | | |
|-------------------------------|-------------|--------------------------------|---|---|---|---|---|---|---|---|---|---|--|
| OUTPUT (SEE S1 INST PLATE) | CONTACT SET | | | | | | | | | | | | |
| | A | B | C | D | E | F | G | H | I | J | K | L | |
| 120/208V 3 ϕ L0,L1,L2,L3 | | | X | | X | X | | X | | | | X | |
| 120V 3 ϕ L1,L2,L3 | X | | | X | | | X | X | | | X | | |
| 120V1 ϕ L2,L3 | X | X | | X | | | X | | | X | | | |
| 240V1 ϕ L2,L3 | | X | X | | | | X | | X | | | | |

7-4 Relay Panel and Field Flash Switch

a. Removal. Refer to Figure 7-1 and the following instructions to remove the relay panel and field flash switch.

- (1) Tag and disconnect leads from the relay panel and the field flash switch.
- (2) Remove the nuts, washers, and screws that secure the relay panel to the control box.
- (3) Remove the relay panel.
- (4) Remove the locking nut that secures the field flash switch to the relay panel.
- (5) Remove the field flash switch.

b. Cleaning and Inspection.

- (1) Clean the field flash switch and relay panel using a clean lint free cloth to remove any accumulated deposits.
- (2) Inspect switch contact for corroded or burned terminal.
- (3) Inspect terminal board for cracks, breaks, corroded terminals, or other apparent damage.
- (4) Inspect relays and resistors for signs of overheating or other damage.

c. Testing.

- (1) Refer to figure FO-2 for resistor rating. Use a multimeter and test on the appropriate resistance (ohm) scale.
- (2) Test the field flash switch for continuity while the switch is held in the closed (ON) position.

d. Repair. Replace a damaged or defective field flash switch or relay panel.

e. Installation.

- (1) Position the field flash switch in place on the relay panel and secure with locking nut.
- (2) Position the relay panel in place in the control box and secure with screws, washers, and nuts.
- (3) Reconnect leads.

7-5. Current Transformer (CT) and Resistors

a. On-Equipment Testing.

- (1) Disconnect the current transformer leads and remove the three resistors.



Never disconnect the leads of a current transformer, either at the transformer or at a meter connected to the transformer, when the equipment is energized. The three resistors used with this equipment are connected across the secondary windings of the current transformer and they ordinarily prevent an open circuit condition. But, if a resistor were to fail and then the secondary were to be open-circuited by disconnecting its load (the meter), extremely high voltages would be induced in the windings. Serious damage to the equipment and possibly the death of personnel could result.

(2) Use a multimeter set on the RX1 scale and test between transformer terminals A1 and A2, B1 and B2, and C1 and C2. Continuity should be shown all three tests.

(3) Now, test between transformer terminal A1 and B1, between A1 and C1, and between B1 and C1. There should be no continuity indicated in any of these three tests.

(4) Connect the meter, in turn, across the terminals of each resistor and measure the resistance. The resistance should measure within one percent above or below 305 ohms (301.95-308.05 ohms).

b. Removal. Refer to figure 7-1 and the following instructions for removal of the current transformer.

(1) Tag and disconnect leads from the resistors and the current transformer.

(2) Remove the screws, washers, and transformer mounting strap securing the current transformer to the control panel.

(3) Remove the current transformer.

c. Cleaning and Inspection.

(1) Clean the current transformer using a clean lint free cloth to remove any residue.

(2) Inspect current transformer and resistors for evidence of overheating.

(3) Inspect transformer case for cracks, breaks, or other damage and resistor mounting studs for corrosion or thread damage.

d. Repair. Replace a damaged or defective current transformer or resistor(s) as required.

e. Installation.

(1) Position current transformer **in place in the control box.**

(2) Secure with transformer mounting strap, washers and screws.

(3) Reconnect leads to the current transformer and field flash switch.

7.6 Bench Test and Repair Procedure (Voltage Regulator).

a. General. This paragraph provides instructions covering test and repair procedures for Voltage Regulator NSN: 6110-00-764-7621; P/N **13219E0883(97403).**

b. Removal. Using figure 7-2 as a guide, remove the Voltage Regulator as follows:

(1) Remove screws and washers securing access panel and remove panel (fig 7-2).

(2) Tag and disconnect all electrical leads.

(3) Remove four (4) screws and lockwashers.

(4) Remove the Voltage Regulator.

c. Test Equipment and Material Required:

(1) Multimeter - TS 352, 1M105 or equivalent.

(2) Resistor, Fixed: 30 OHMS tolerance at minimum 25 Watt rating.

(3) Rheostat, Variable; 750 OHMS at 25 Watt rating (Rheostat supplied with serviceable Voltage Regulators).

(4) Soldering Iron: Small tip, 500-700 Degree Fahrenheit rated.

(5) Solder, Rosin Core.

(6) Voltage Source: 110-120 Volts AC, single phase, 60 HZ.

d. Test Procedures.

WARNING

Extreme care should be taken while conducting test involving use of the 110-120 60 HZ Voltage Source for safety of personnel, and damage to equipment being used.

CAUTION

While using a soldering iron, caution should be taken to prevent damage to components, and printed Circuit board from excessive prolonged applied heat. Damage could result to replacement items, rendering them unsuitable for operation.

(1) With Voltage Regulator removed from the generator set, place multimeter being used on OHMS position RX 100.

(2) Remove two (2) screws located on the extreme Left and Right side of the terminal strip, TB1. Gently pull the terminal strip along with the Circuit board upward making sure that wiring leads are free from regulator housing and components.

NOTE

Before any point to point checks can be made, scrape ends of items being checked to insure that a good electrical contact can be made. Recoat with varnish after repair or test.

CAUTION

Do not remove the white paste from the micro spacer or regulator housing. If this dielectric heat transfer paste is removed, destruction of Q2 will occur.

(3) Locate CR5, 1N414 D10DE, measure resistance, reverse test leads and measure resistance again. Acceptable limits are LOW resistance of 9-11 OHMS one way, and more than 100,000 OHMS the other way. If LOW or HIGH resistance is measured in both directions, remove and replace CR5.

(4) Locate CR6, 1N5296/1N5297 Current Regulating Diode and perform tests in paragraph d., (3) above. If resistance is LOWER than 800 OHMS in both directions, locate Q1 2N2405 Transistor, remove and replace it. After replacing Q1, measure the resistance of CR6. If readings are still not within limits, remove CR6, then replace it.

(5) Locate Q2 2N3442 Power Transistor, located on back of regulating housing. Remove two (2) screws securing Q2 to the housing. Pull straight from housing, being careful not to damage the micro spacer beneath the body of Q2.

(6) Set the multimeter to RX 10,000 OHMS, Resistance Test. Position Q2 2N3442 with the two (2) pins of the device pointing toward individual, line up the pins so they are in the lower half of the device with the two (2) mounting holes at the top and bottom. While in this position the pin on the left hand side is the Emitter, the pin on the right hand side is the base and case of the device, and is the Collector. Test with the Black lead of the multimeter on the transistor body and Red lead on the LEFT pin, then the RIGHT hand pin of the transistor. There should not be any movement of multimeter point. Reverse the leads and perform same procedures. Readings should indicate no movement of the multimeter pointer on Left hand pin should read between 10,000 OHMS, to 20,000 OHMS on Right hand pin. LOW or HIGH resistance on both pins as a result of the above two checks, indicate either an open or shorted junction within Q2, replace Q2. Replace Q2 along with the mica insulator located between the transistor body and the regulator housing.

(7) Connect the 30 OHM, 25 Watt resistor to terminals 20 and 21 of TB1. Connect two (2) 12-18 AWG insulated wires to the 750 OHM Rheostat as follows:

(a) First position Rheostat with shaft control toward individual and three (3) terminal lugs in back at 12:00 O'Clock position. Connect one (1) wire to middle lug and one (1) wire to the right hand lug. If the Rheostat has a jumper wire connected across any two (2) terminals, remove the jumper wire. Connect the 750 OHM Rheostat to terminals 26 and 28 of TB1 on the Voltage Regulator. Turn the shaft of the Rheostat clockwise to its maximum rotation.

(b) Connect the 110-12060 HZ AC Voltage Source to terminals 24 and 27 of TB1.

(c) Set the multimeter on 50 DC Volt range. Test for 26-32 DC Volts between terminals 20 and 21 of TB1. Positive polarity on terminal 20, and Negative polarity on terminal 21. Rotate shaft of Rheostat counter clockwise to approximately eighty (80) percent of rotation, somewhere in this position the voltage at terminals 20 and 21 of TB1 should collapse to Zero volts. Rotate the shaft of Rheostat clockwise until somewhere near eighty (80) percent of rotation, the voltage should reappear on terminals 20 and 21 to the 26-32 DC Volt range. In the event that there is a pause longer than two seconds before the voltage increases or decreases when resetting of the Rheostat, then an adjustment of R6 must be made.

(d) Locate R6 on the circuit board. By turning the adjustment screw of R6 counter clockwise, the voltage will be on at terminals 20 and 21 of TB1. By turning clockwise, the voltage will collapse to Zero.

NOTE

There will not be an adjustment of R6 to where the voltage at terminals 20 and 21 can be made to viny. Either the voltage will be ON or OFF.

Adjust R6 accordingly to subparagraph **d.**, (7), (c). Once this is accomplished there are no further tests required.

(e) Should the voltage at terminals 20 and 21 of TB1 remain ON, regardless what position the 750 OHM Rheostat is in, then proceed with the following steps:

NOTE

This also applies if NO voltage is detected at terminals 20 and 21 of TB1.

WARNING

Turn OFF Electrical Power before inspection and repair.

Step 1. Inspect the circuit board for burned or broken printed circuit paths. Bridge all open circuit paths with solid 22 AWG wire, making certain that adjacent circuit paths are not shorted by solder flow.

Step 2. If no open circuit paths or loose connections of components exist, locate R1, R2, VR1 and VR2. With the 110-120 Volts AC Source connected to TB1, terminals 24 and 27, a reading of 28 Volts DC should be detected with Positive polarity at R1 to VR1 junction, and Negative polarity at R2 to VR2 junction.

Step 3. If the voltage is lower or higher than 28 Volts DC, check the voltage across VR1 and CR2.

CAUTION

If either diode is removed from the circuit board, do not apply the 110-120 AC Voltage Source at any time after diode is removed, until the replacement is connected to the circuit. Failure to observe this precaution could cause the supply voltage being increased beyond a maximum limit for ARI causing complete failure of the device.

Step 4. After checking the voltage across each diode, replace either one of the two or both, that does not regulate the supply voltage to fourteen (14) DC Volts across each diode.

Step 5. After replacing any one of the two (2) diodes or if there is no voltage detected across either or both diodes, check the AC Voltage between terminal lugs 7 and 8 of TI Power Transformer.

NOTE

Change setting of Multimeter to (AC Volt, 50 Volt range).

Voltage reading between 36-40 Volts AC should be present. If voltage is not present, T1 Power Transformer should be checked to make certain that 110-120 AC input voltage is connected properly, and all wiring connections to T1 are not loose or disconnected. If this procedure proves all wiring connections to be correct, replace T1.

Step 6. After verifying that 36-40 Volts AC present, locate CR5 and CR9 on the circuit board. Remove the 110-120 Volt AC voltage and disconnect one end of each CR8, or CR9 nine (9) diodes. Set multimeter on the RX 10,000 OHMS scale. A good diode will have no meter movement (High Resistance) with test leads applied, in any direction and LOW Resistance with test leads reversed. Remove and replace CR8, or CR9 if any of the two tests prove defective. Install serviceable diodes.

Step 7. Locate C1, and C2 on the reverse side of the circuit board. With one end of each capacitor disconnected from the circuit board, check the resistance of each capacitor with the multimeter set for RX 10,000. Connect test lead of the multimeter to the POSITIVE scaled end of C 1.

NOTE

The meter pointer should deflect to the right half side of scale, then slowly return to somewhere past mid-scale toward left half of scale. If capacitor is shorted or leaky, the pointer will remain on the right lower half of the scale. If capacitor is Open there will be no movement of the pointer. Check C2 using the above method. Remove and replace C1 and (72, if found to be defective. If in doubt compare the tests of C1 and C2 with a new capacitor, using the results of the comparison for future tests.

f. Locate VR3 and apply the 110-120 Voltage Source on terminals 24 and 27 of TB1. Check the voltage across VR3. This is a 4.7 Volt Zener diode. Remove VR3 and replace if the voltage is higher than 4.7 Volts. If no voltage can be detected across VR3, located R3, 1K OHM resistor. Check the voltage at R3 to VR2 junction. There should be a Negative 14 DC Volts present with respect to F terminal on TB1. If Negative 14 DC Volts present with respect to F terminal on TB1. If Negative 14 Volts is present and there is still no voltage across VR3, remove and replace VR3.

g. In the event that none of the above checks and replacement of components cause the regulator to perform in acceptable limits, then AR1 is defective and needs to be replaced.

CAUTION

Extreme care must be used while removing AR1 from the circuit board.

There are seven (7) connecting pins on the body of AR1, locate the two (2) pins on one side and apply the tip of the soldering iron alternately to both pins while prying up the body of AR1 with a small flat tip screwdriver. Once one side of AR1 is free, repeat the same procedure on the remaining pins and again pry upward until AR 1 is free of the circuit board.

NOTE

While replacing AR1, it is good practice to clean the circuit paths of solder where the seven (7) pins of AR1 protrudes through the circuit board.

h. Refer to the schematic diagrams for circuit review and analysis. If replacement parts are required, order by part number and manufacturers code as indicated on fold-outs FO5 and FO6, located in the back of the manual.

i. After all tests, repair or replacement of parts have been accomplished, recoat using Varnish (MIL-I-24092, Type M, Class 155).

NOTE: TAG AND DISCONNECT ELECTRICAL LEADS.

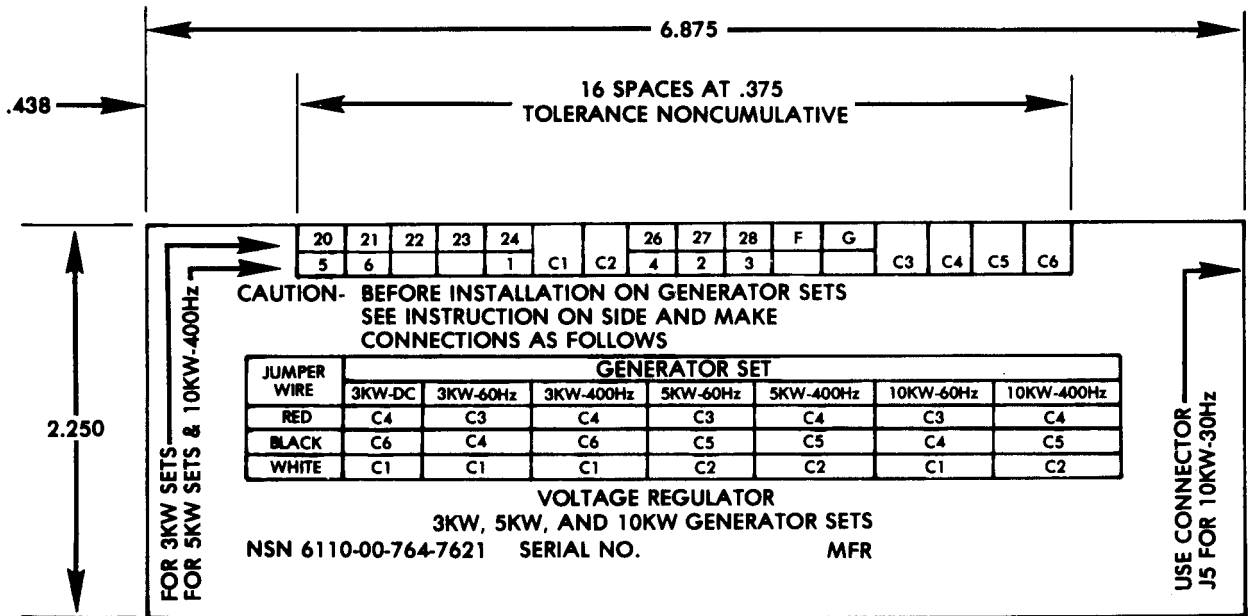
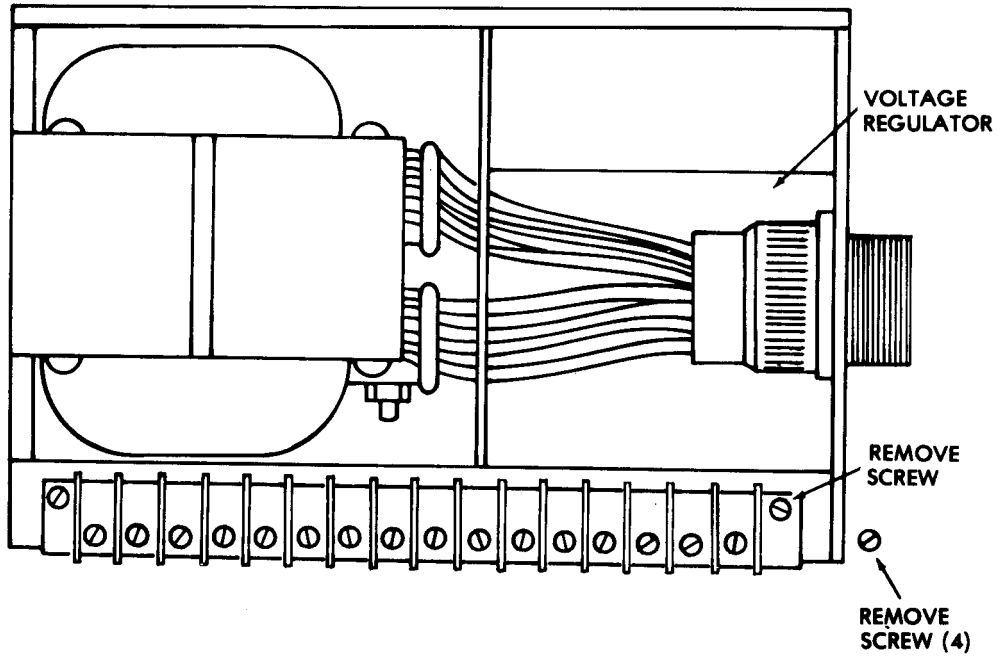
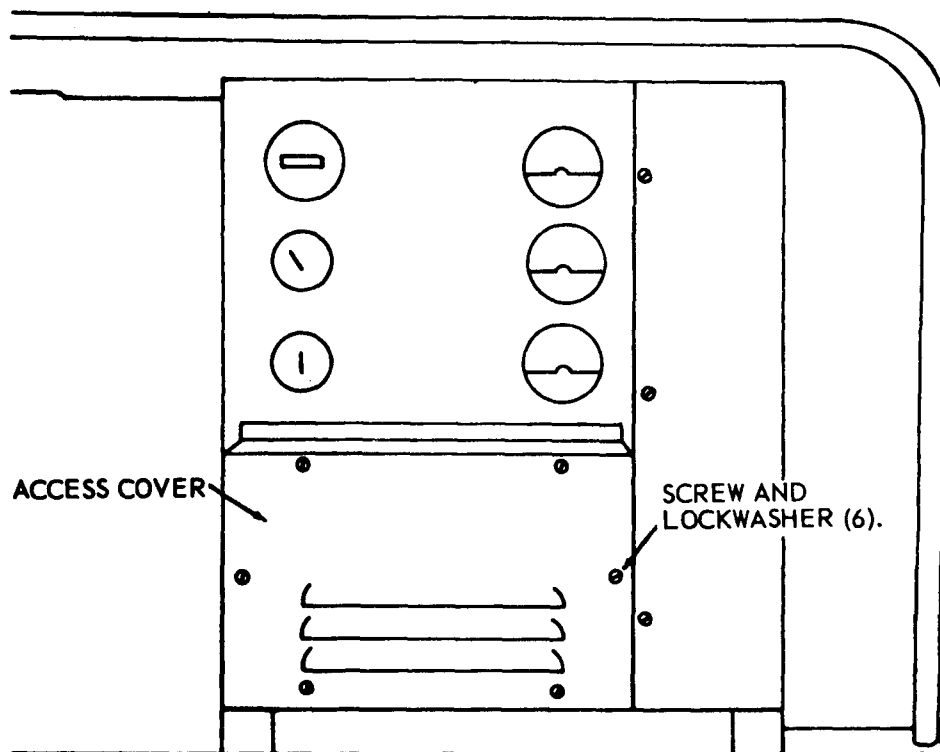
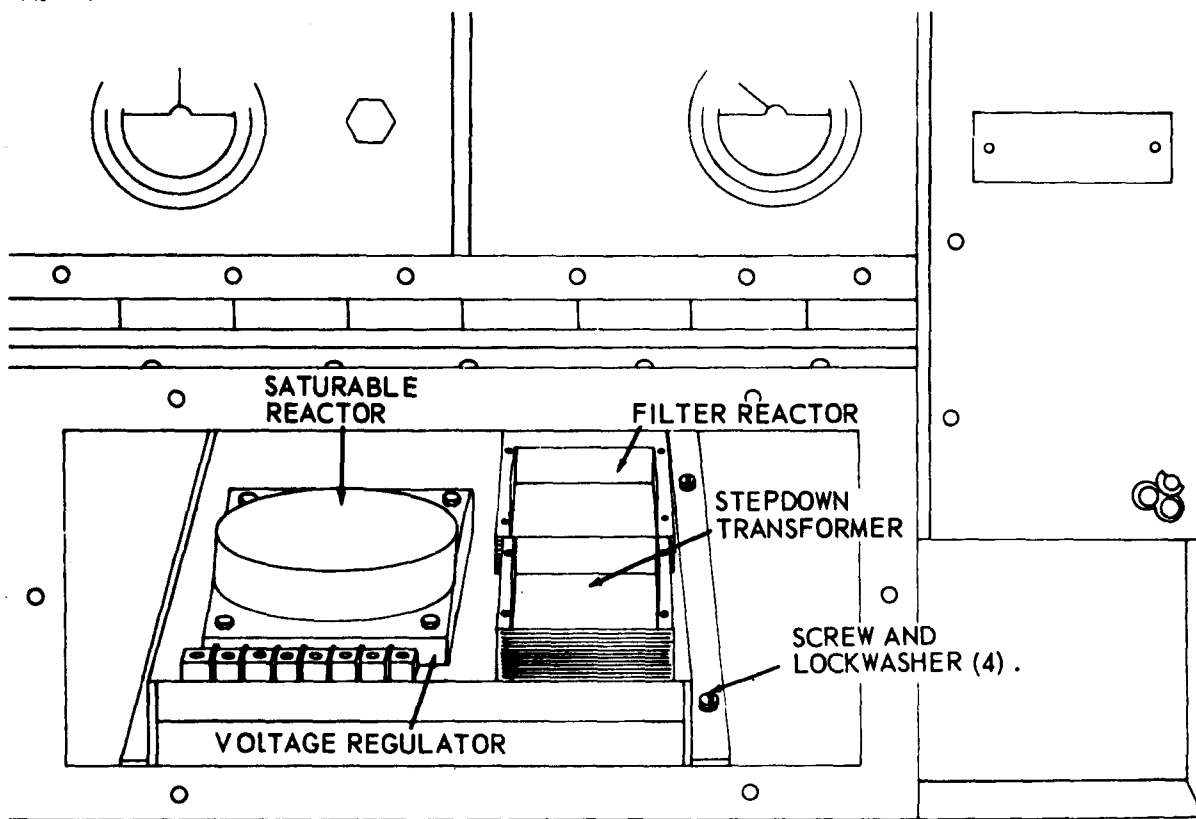

Figure 7-2 Voltage regulator removal and installation.



A. ACCESS COVER



B. VOLTAGE REGULATOR

Figure 7-3. Voltage regulator removal and installation.

e. Cleaning and Inspection.

(1) Clean the voltage regulator using a clean lint free cloth.

(2) On old style regulators inspect saturable reactor, filter reactor, stepdown transformer and voltage regulator for cracks, breaks, evidence of overheating or other damage.

f. Repair. Replace a damaged or defective voltage regulator.

g. Installation.

(1) Place voltage regulator (PN 13219E0883 (97403)) in position in the control box and secure with washers and screws.

(2) Connect electrical connectors to the voltage regulator.

(3) Position access panel in place on control box and secure with washers and screws.

(4) Place voltage regulator (PN 13211E6975 (97403) or 13212E8950 (97403)) in place in control box and secure with washers and screws.

(5) Reconnect wiring.

(6) Position access cover in place on control box and secure with washers and screws.

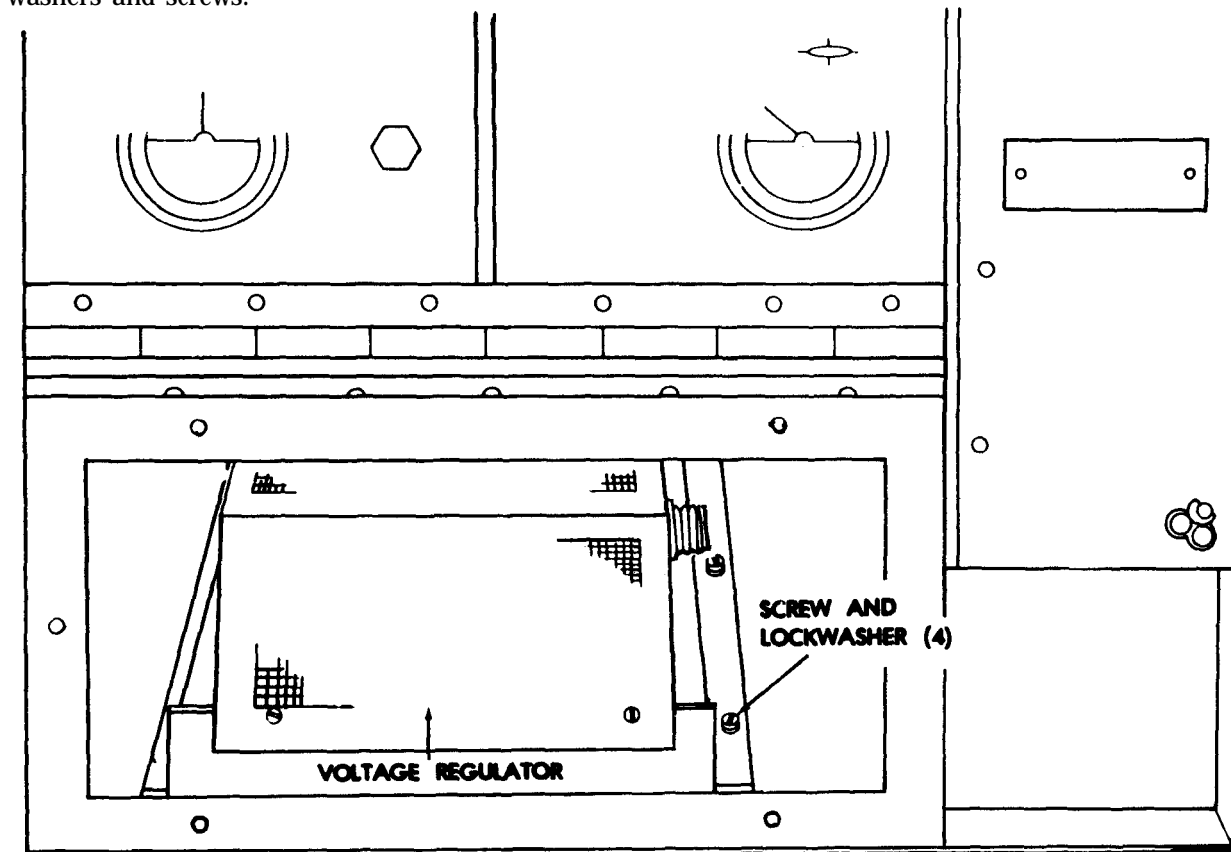

TS 6115-332-14-7-4

Figure 7-4. Voltage regulator, removal and installation, PN 13219E0883 (97403).

7-7. Wiring and Wire Harness

a. General. All of the generator set wiring can be identified by identification numbers on the wire. The wiring can be systematically checked by reference to the wiring diagrams (figs. FO-2 and FO-4).

b. Testing and Replacement. To test, disconnect both ends of the wire under test. Touch the probes of the multimeter to each end of the wire. If

an open circuit is indicated, replace the wire. Always use a wire of at least equal size. Individual wires may be substituted for the defective wires in a wiring harness by running a new wire along side the harness. Tape, lace, or use plastic wire straps to secure the wire and make it an integral part of the harness.

7-8. Load Terminal Board (TB1)

a. Removal. Refer to figure 7-5 and the following instructions to remove the load terminal board.

(1) Tag and disconnect electrical leads as necessary.

(2) Remove the nuts, washers and screws which secure the load terminal board to the control box.

(3) Remove the load terminal board.

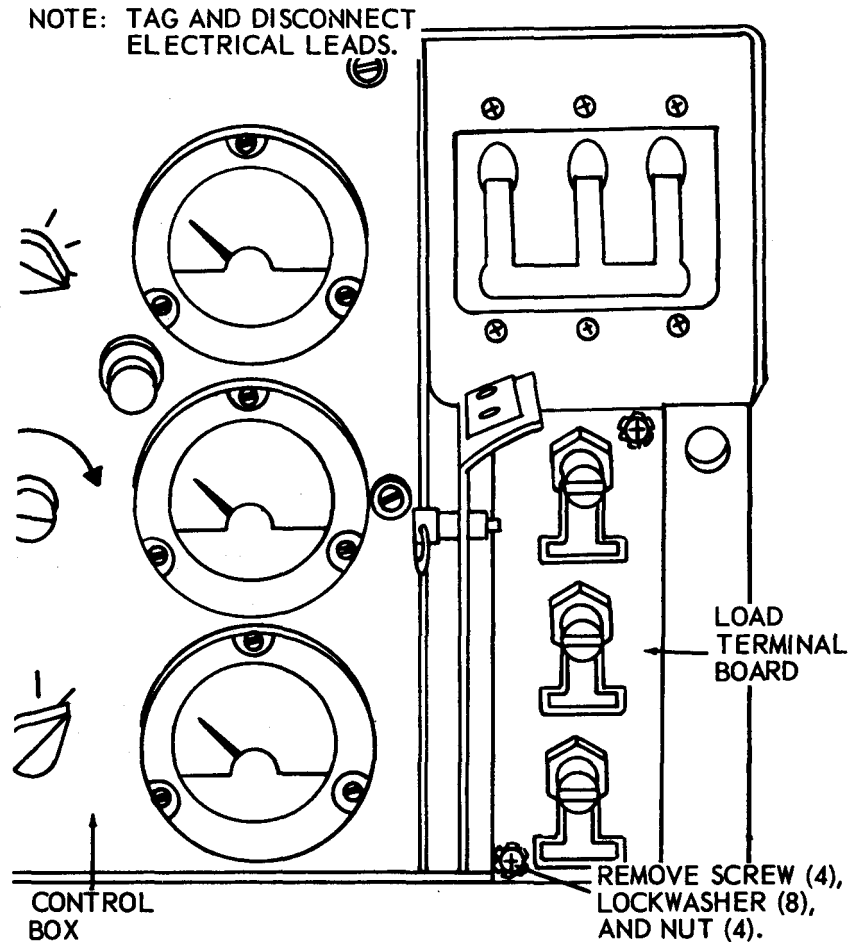

TS 6115-332-14/7-1

Figure 7-5. Load terminal board, removal and installation.

b. Cleaning, Inspection and Repair.

WARNING

Clean all parts in a well-ventilated area. Avoid inhalation of solvent fumes and prolonged exposure of skin to cleaning solvent. Wash exposed skin thoroughly. Dry cleaning solvent (Fed. Spec. P-D-680, Type 11) used to clean parts is potentially

dangerous to personnel and property. Do not use near open flame or excessive heat. Flash point of solvent is 140°F(60°C).

(1) Clean the load terminal board thoroughly with a clean cloth dampened in cleaning solvent, Fed. Spec. P-D-680 Type II, and dry thoroughly.

(2) Inspect the load terminal board for cracks, and burned areas,

(3) Inspect the terminals for damaged threads.

(4) Replace a damaged load terminal board.

c. Installation.

(1) Position the load terminal board in place on the control box.

(2) Secure the load terminal board with washers, screws and nuts.

(3) Reconnect electrical leads.

7-9. Remote Control Terminal Board (TB3)

a. Removal. Refer to figure 7-6 and the following instructions to remove the remote control terminal board.

(1) Tag and disconnect electrical leads as necessary.

(2) Remove the nuts, screws, and washers which secure the remote control terminal board to the control box.

(3) Remove the remote control terminal board.

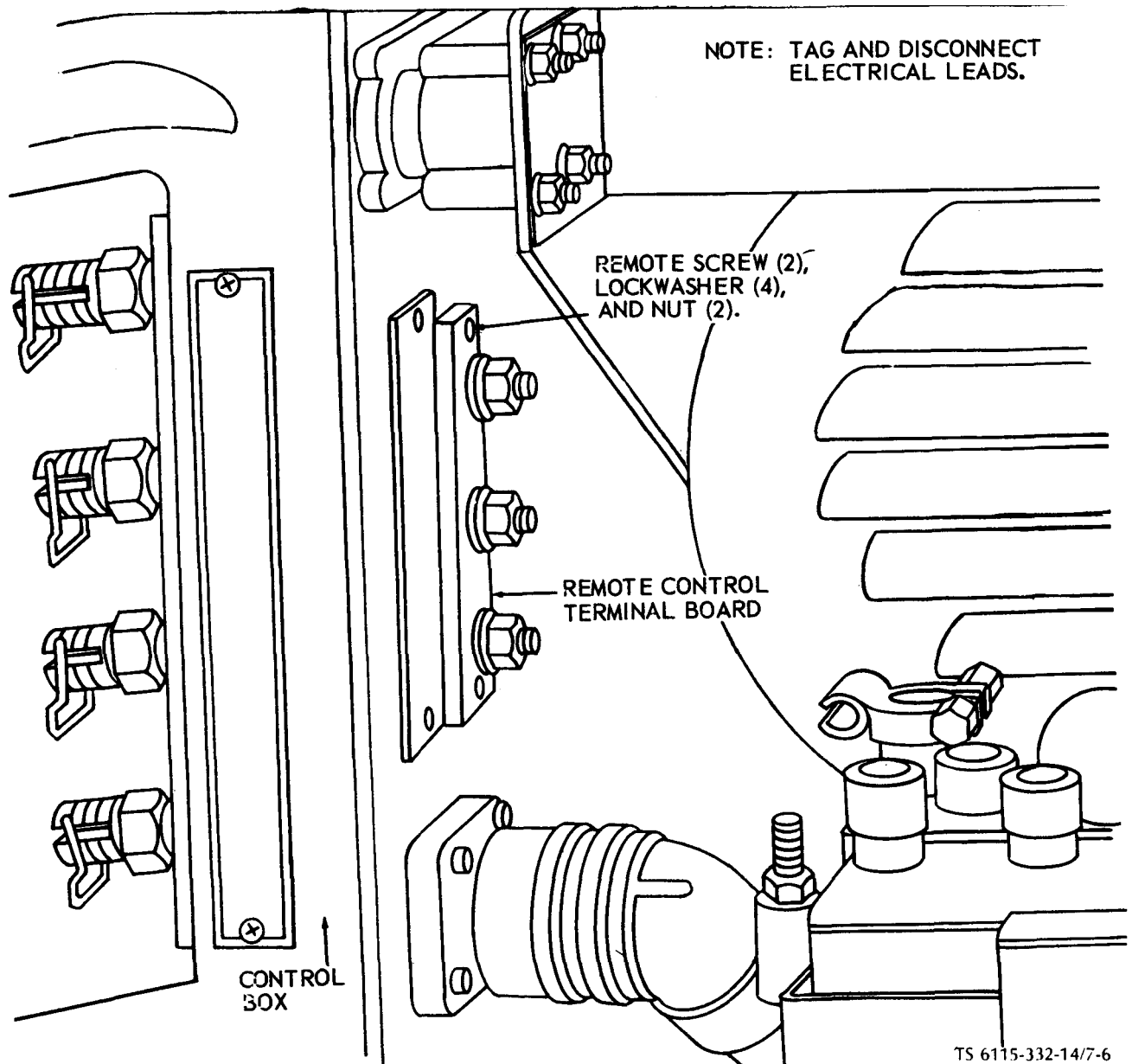

Figure 7-6. Remote control terminal board, removal and installation (TB3).

b. Cleaning, Inspection and Repair.

WARNING

Clean all parts in a well-ventilated area. Avoid inhalation of solvent fumes and prolonged exposure of skin to cleaning solvent. Wash exposed skin thoroughly. Dry cleaning solvent (Fed. Spec. P-D-680, Type II) used to clean parts is potentially dangerous to personnel and property. Do not use near open flame or excessive heat. Flash point of solvent is 140 °F (60 °C).

(1) Clean items with a cloth dampened in cleaning solvent, Fed. Spec. P-D-680 Type II, and dry thoroughly.

(2) Inspect for burned areas and cracks.

- (3) Inspect the terminals for stripped threads.
- (4) Replace a damaged terminal board.

c. Installation.

- (1) Position the remote control terminal board in place on the control box.
- (2) Secure the remote control terminal board to the control box with screws, washers, and nuts.
- (3) Reconnect electrical leads.

7-10. Terminal Board (TB2)

a. Removal. Refer to figure 7-7 and the following instructions to remove the terminal board.

- (1) Tag and disconnect electrical leads as necessary.
- (2) Remove the nuts, washers, and screws which secure the terminal board to the control box.
- (3) Remove the terminal board.

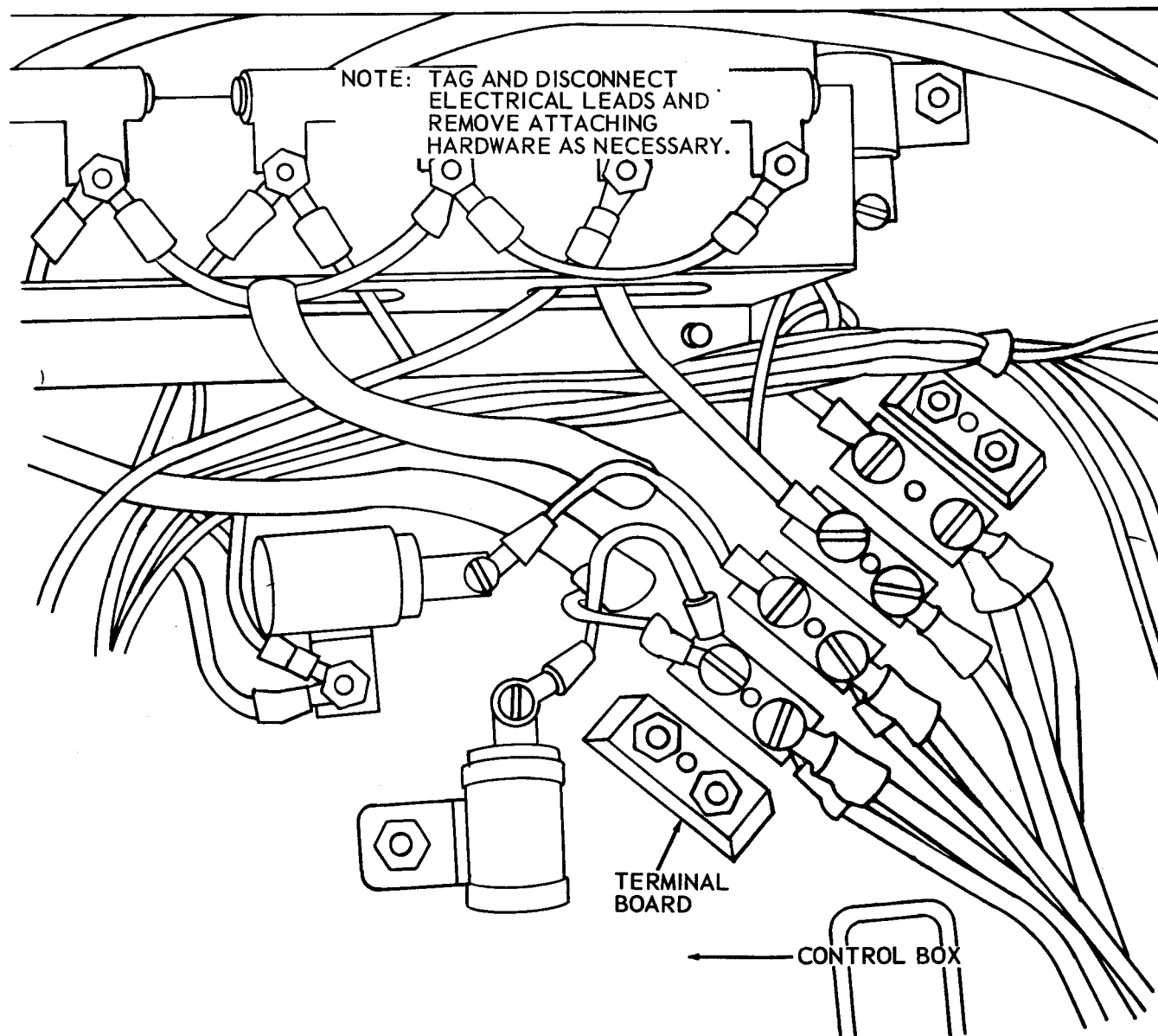

TS 6115-332-14/7-7

Figure 7-7. Terminal board, removal and installation (TB2).

b. Cleaning, Inspection and Repair.

- (1) Clean the terminal board thoroughly.
- (2) Inspect for burned areas, cracks, and damaged terminals.
- (3) Replace a defective terminal board.

c. Installation.

- (1) Position terminal board in place on the control box.
- (2) Secure the terminal board with screws, washers and nuts.
- (3) Reconnect electrical leads as required.

Section II. MAINTENANCE OF THE GENERATOR

7-11. General

The generator housing is mounted directly on the flywheel housing (Model MEP-017A) or mounted on the flywheel housing by use of an adapter (Model MEP-022A). The rotor is mounted on a flexible drive disk that, in turn, is mounted on the engine flywheel. The rotor is made up electrically of two sections, the alternator field and the brushless, rotating exciter section. The generator housing houses both the generator (alternator) stator windings and the dc exciter frame and field windings.

7-12. On-Equipment Testing

a. General. On-equipment electrical test procedures may provide a basis for determining the necessity and extent of generator repair. The resistance values and tolerances contained in this paragraph should be used only as a general guide. Take into consideration the test instrument used, test lead resistance, and the ambient temperature at the time of the test. If more precise measurements are required, use an instrument such as a Kelvin Balance or a Wheatstone Bridge and make comparative measurements between the suspected component and a like item that is known to be good.

b. Stator.

(1) Disconnect the plug connector (Pi) at the rear of the control box.

(2) Use a multimeter that has been set on the RX1 scale and test for continuity between plug pins A and B, D and E, and C and F. If continuity is not indicated (full deflection) on any of the tests, remove the plug at the generator and repeat the tests at the generator. If, again, continuity is not shown, the stator is defective and must be replaced. If continuity is shown the cable is defective and must be replaced.

c. Rotor.

(1) Remove the blower cover and fan (para 6-2 or 6-3).

(2) Use a multimeter that has been set on the RX1 scale and test between the rotor field windings terminal and the case of the rotor. If the resistance is not within five percent above or below the following values, the rotor must be removed for further testing (TM 5-764):

Model MEP-017A (60 Hertz) 8.8 ohms
Model MEP-022A (400 Hertz) 0.615 ohms

d. Exciter Field Windings.

(1) Disconnect the plug connector (Pi) at the rear of the control box.

(2) Use a multimeter that has been set on the RX1 scale and test for continuity between plug pins G and H. If the resistance is not within five percent above or below 54.4 ohms, the windings are defective and must be replaced.

7-13. Main Generator Stator and Housing Assembly

a. Removal. For generator removal instructions, refer to paragraphs 6-2 and 6-3.

NOTE

It is also possible to remove the engine and generator as a unit. If this is to be accomplished, refer to paragraph 6-4 and follow the instructions on removal of the engine from the skid.

b. Disassembly.

(1) Model MEP-017A.

(a) Tag and disconnect all leads.

(b) Remove screws (1, fig. 7-8) and lockwashers (2) and remove the wire clips (3) from the exciter frame (24).

(c) Remove screws (4) and lockwashers (5) and remove the wiring harness (6) from the housing (25).

(d) Disassemble the wiring harness (6) by removing connector (7) at clamp (8) and adapter (9) at clamp (10) from the leads and sleeving (11).

(e) Remove the air inlet grille (12) from the housing (25).

(f) Remove the lifting eyebolt (13) and nut (14) from the housing (25).

(g) Remove capscrew (15) and lockwashers (16) and remove the stator (17).

(h) Remove capscrews (18) and lockwashers (19) and remove the exciter frame assembly (24) from the housing (25).

(i) Remove screws (20) and lockwashers (21) and remove the exciter pole (22) and exciter coil (23) from the exciter frame assembly (24).

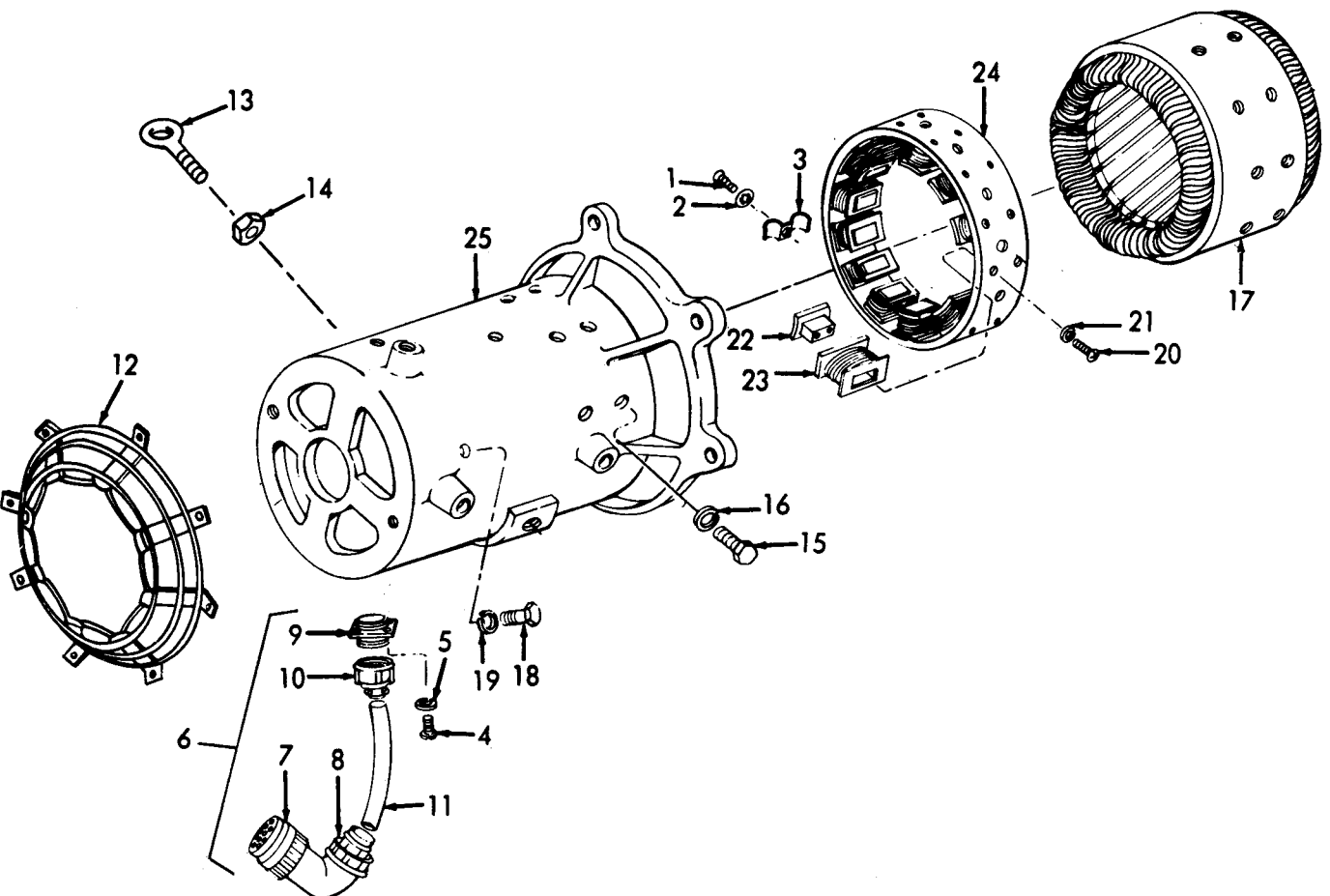

TM 5-6115-332-14
P-8-614-14
TO 35C2-3-424-1

1. Screw
2. Lockwasher
3. Clip
4. Screw
5. Lockwasher
6. Wiring harness
7. Connector
8. Clamp
9. Adapter
10. Clamp
11. Sleeving
12. Grille
13. Eye bolt

14. Nut
15. Capscrew
16. Lockwasher
17. Stator
18. Capscrew
19. Lockwasher
20. Screw
21. Lockwasher
22. Pole
23. Coil
24. Frame ay
25. Housing

TS 6115-332-14 7-8

Figure 7-8. Main generator stator and housing assembly, disassembly (Model MEP-017A).

(2) Model MEP-022A.

(a) Tag and disconnect all leads.

(b) Remove screws (1, fig. 7-9) and lockwashers (2) and remove the wire clips (3) from the exciter frame (27).

(c) Remove screws (4) and lockwashers (5) and remove the generator wiring harness (6) from the housing (28).

(d) Disassemble the wiring harness (6) by removing connector (7) at clamp (8) and adapter (9) at clamp (10) from the leads and sleeving (11).

(e) Remove the lifting eyebolt (12) and nut

(13) from the housing (28).

(f) Remove capscrews (14) and lockwashers (15) and remove the generator housing adapter (16) and air inlet grille (17) from the housing (28).

(g) Remove capscrews (18) and lockwashers (19) and remove the stator (20).

(h) Remove capscrews (21) and lockwashers (22) and remove the exciter frame assembly (27) from the housing (28).

(i) Remove screws (23) and lockwashers (24) and remove the exciter pole (25) and exciter coil (26) from the exciter frame assembly (27).

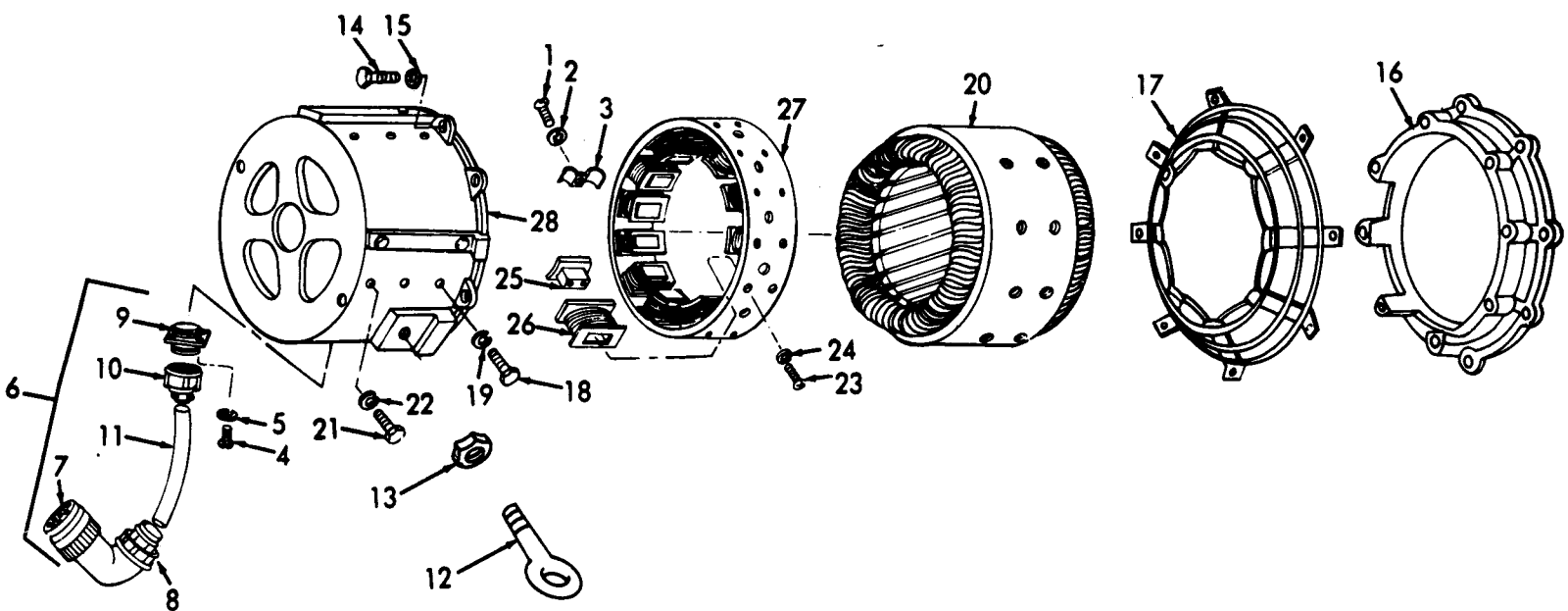

TM 5-6115-332-14
P-8-614-14
TO 35C2-3-424-1

- | | |
|-------------------|--------------------|
| 1. Screw | 15. Lockwasher |
| 2. Lockwasher | 16. Adapter |
| 3. Clip | 17. Grille |
| 4. Screw | 18. Capscrew |
| 5. Lockwasher | 19. Lockwasher |
| 6. Wiring harness | 20. Stator |
| 7. Connector | 21. Capscrew |
| 6. Clamp | 22. Lockwasher |
| 9. Adapter | 23. Screw |
| 10. Clamp | 24. Lockwasher |
| 11. sleeving | 25. Pole |
| 12. Eyebolt | 26. Coil |
| 13. Nut | 27. Frame assembly |
| 14. Capscrew | 28. Housing |

TS 6115-332-14/7-9

Figure 7-9. Main generator stator and housing assembly, disassembly (Model MEP-022A).

c. Cleaning.

WARNING

Clean all parts in a well-ventilated area. Avoid inhalation of solvent fumes and prolonged exposure of skin to cleaning solvent. Wash exposed skin thoroughly. Dry cleaning solvent (Fed. Spec. P-D-680, Type II) used to clean parts is potentially dangerous to personnel and property. Do not use near open flame or excessive heat. Flash point of solvent is 1400 F (600 C).

Clean items with cleaning solvent, Fed. Spec. P-D-680 Type II, and dry thoroughly.

d. Inspection.

- (1) Inspect the stator windings and leads for broken or damaged wires.
- (2) Inspect the main frame and exciter frame

for damage, broken welds and cracks at the mounting flanges.

(3) Inspect the exciter coils and field windings for signs of burned areas, abrasion and other damage.

(4) Inspect the generator housing for cracks, wear and other physical wear.

(5) Check for missing and damaged hardware.

e. Repair.

(1) Remove and replace all defective wiring that can be replaced without disturbing the stator windings. Windings that show only very minor abrasion and no breakage may be repaired by re-varnishing.

NOTE

Be certain that bare windings are not touching before applying electrical varnish.

(2) Dipping and baking varnish can be accomplished by following steps (a) through (j) below, and figures 7-10 and 7-11.

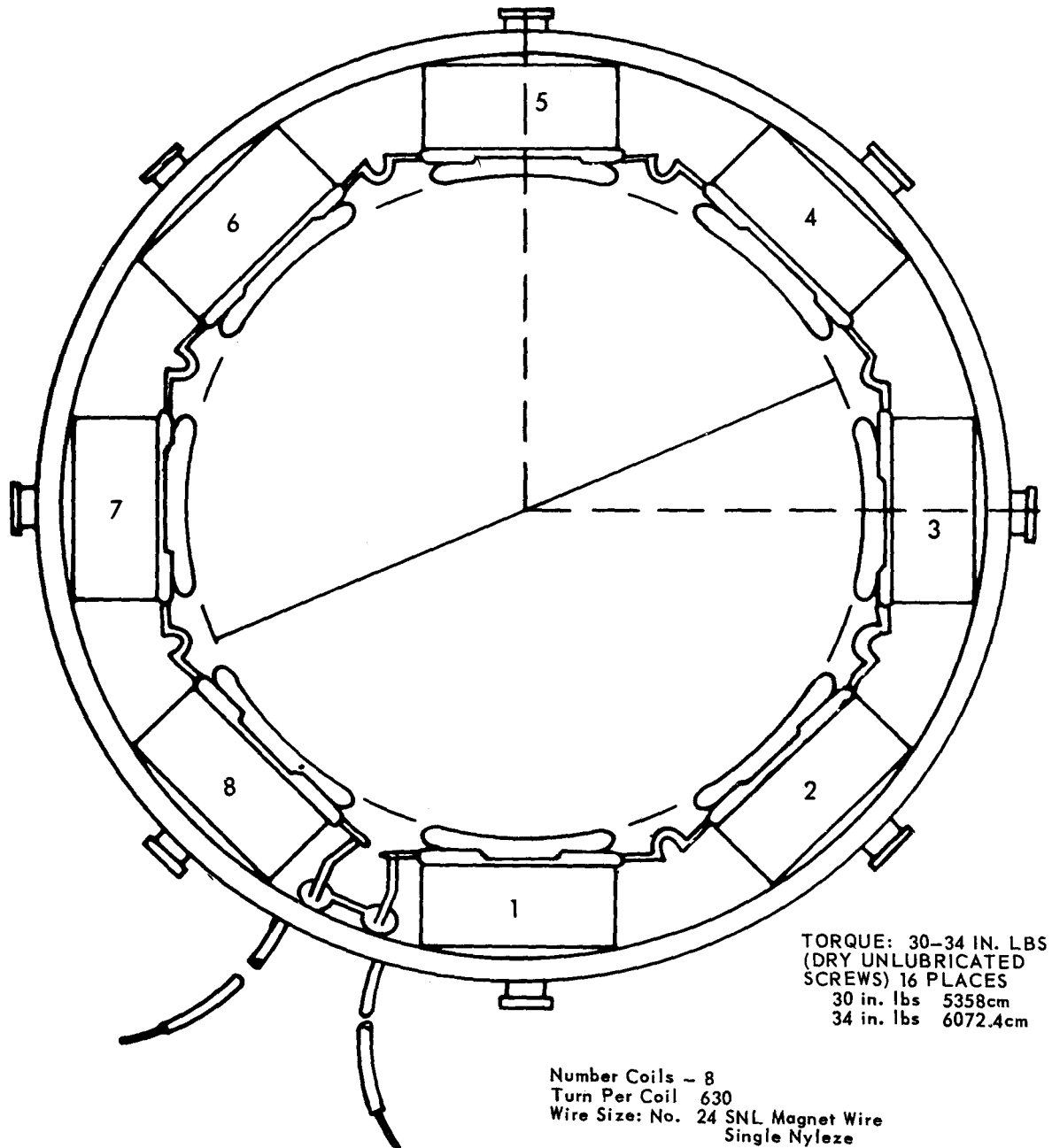

TS 6115-332-14/7-10

Figure 7-10. Exciter field frame assembly, repair.

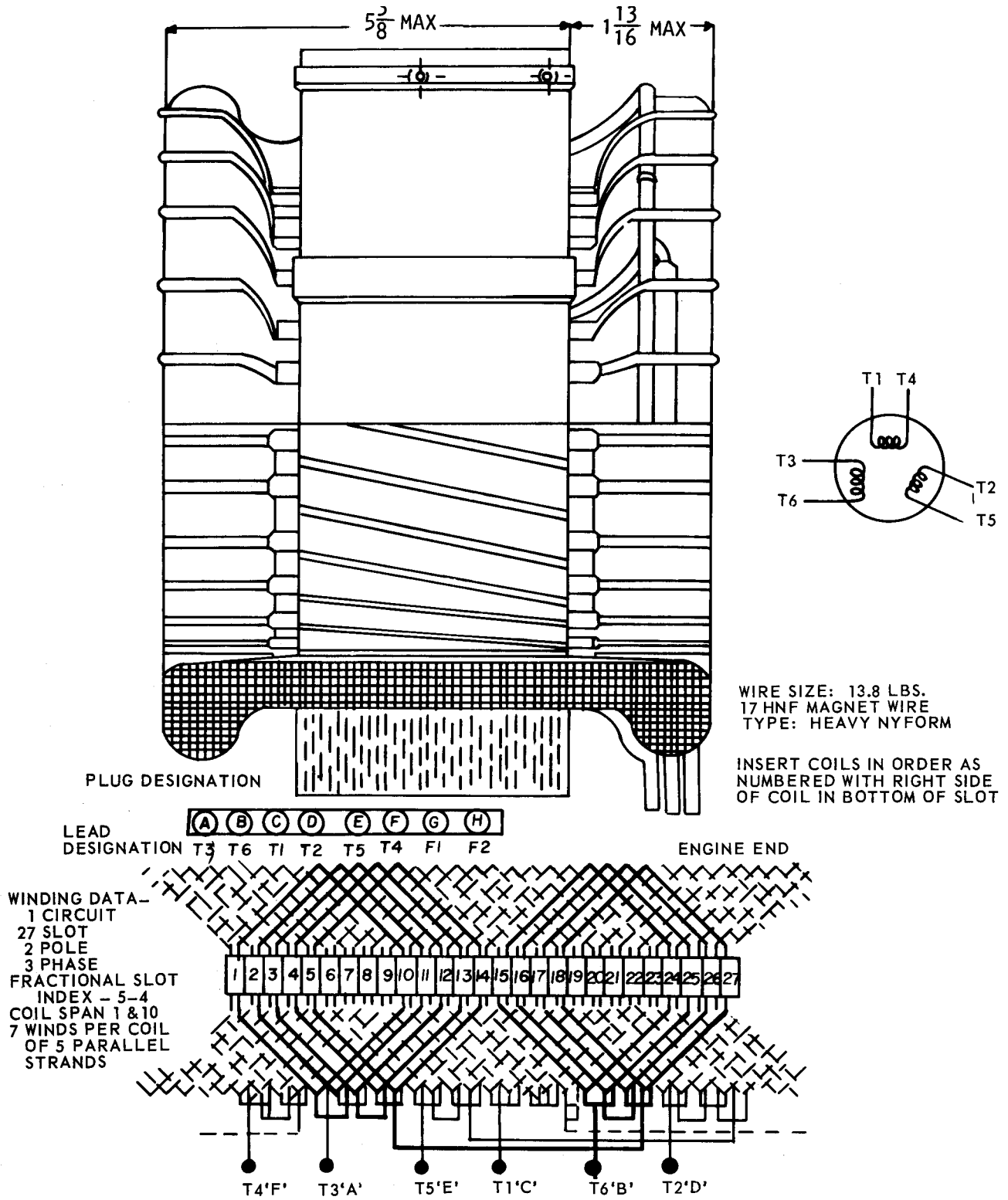

Figure 7-11. Alternator stator, repair.

NOTE

Do not bake the rotating rectifier assembly. Keep all varnish from the rotor shaft.

(a) Maintain the viscosity of the varnish at the manufacturer's recommended value.

(b) The part shall be clean and free of all foreign matter.

(c) Preheat the part for two hours at a temperature of 290 to 310°F. (143 to 154°C.).

(d) Cool the part to a temperature of 120 to 250°F. (49 to 121°C.) before dipping.

(e) Dip in varnish for two minutes or until bubbling ceases, then drain for 6 to 8 minutes.

(f) Bake for 3 hours at a temperature of 290 to 300°F. (143 to 149°C.).

(g) Repeat steps (d) through (f).

(h) Repeat steps (d) through (e).

(i) Bake for 6 hours at a temperature of 290 to 300°F. (143 to 149°C.).

(j) Cool to room temperature.

(3) Replace a defective stator.

(4) Replace damaged main frame and exciter frame.

(5) Replace damaged generator housing.

(6) Replace missing and damaged hardware.

f. Assembly.

(1) Model MEP-022A.

(a) Install the exciter pole (25, fig. 7-9) and exciter coil (26) on the exciter frame assembly (27); secure with lockwashers (24) and screws (23).

(b) Install the exciter frame assembly (27, fig. 7-9) on the housing (28) and secure with lockwashers (22) and capscrews (21).

(c) Install stator (20) and secure it with lockwashers (19) and capscrews (18).

(d) Install the air inlet grille (17) and adapter (16) on the housing (28); secure with lockwashers (15) and capscrews (14).

(e) Install the eyebolt (12) and nut (13).

(f) Install sleeving (11), clamp (10), adapter (9), clamp (8), connector (7) and wiring harness (6).

(g) Install the wiring harness assembly on the housing (28) and secure it with lockwashers (5) and screws (4).

(h) Install wire clips (3) on exciter frame (27) and secure them with lockwashers (2) and screws (1).

(i) Connect all leads.

(2) Model MEP-017A.

(a) Install exciter coil (23, fig. 7-8) and exciter pole (22) on the exciter frame (24) and secure them with lockwashers, (21) and screws (20).

(b) Install the exciter frame assembly (24) on the housing (25) and secure it with lockwashers (19) and capscrews (18).

(c) Install stator (17), lockwashers (16), and capscrew (15).

(d) Install nut (14) and lifting eyebolt (13).

(e) Install the air inlet grille (12).

(f) Reassemble the wiring harness (6). Install sleeving (11), clamp (10), adapter (9), clamp (8), and connector (7).

(g) Install the wiring harness (6, fig. 7-8) on the housing (25) and secure it with lockwashers (5) and screws (4).

(h) Install the wire clips (3) and secure them with lockwashers (2) and screws (1).

g. Test.

(1) Test the exciter stator (G1) (field windings) for continuity. Use contacts G and H on the generator cable receptacle. If continuity is not indicated, each coil must be tested individually to locate the shorted or open windings. (Refer to wiring schematic diagram FO-1 or FO-2.)

(2) Test alternator stator (G1) windings for continuity. (Refer to wiring schematic diagram, FO-1 or FO-2.) Test across contacts F and C, E and D, and A and B. An open coil that shall be repaired or replaced is indicated by failure to obtain continuity.

(3) Using a megohmmeter, test between the frame and one lead of each winding in the stator. Use the appropriate pins on the generator receptacle on the alternator stator and test between one coil lead and a lead from each coil group, in turn. A reading of less than 1.0 megohm obtained in any test indicates that the insulation is faulty. The defective winding shall be repaired or replaced.

h. Installation. Refer to paragraphs 6-2, 6-3 or 6-4 and reinstall the generator.

7-14. Main Generator Rotor Assembly

a. Removal. For generator removal instructions, refer to paragraphs 6-2 and 6-3.

NOTE

It is also possible to remove the engine and generator as a unit. If this is to be accomplished, refer to paragraph 6-4 and follow the instructions on removal of the engine from the skid.

b. Disassembly.

(1) Model MEP-017A.

(a) Remove the blower fan Woodruff key (1, fig. 7-12) from its slot in the rotor shaft.

(b) Remove bearing clip (2) and with the use of a puller, remove the bearing (3) from the

rotor shaft,

(c) Remove the controlled silicon rectifiers (4), capscrews (5) and lockwashers (6), pull the exciter rotor assembly out, remove the exciter rotor lead screw (7) and remove the exciter rotor assem-

bly (8) from the alternator rotor assembly (12).

(d) Remove capscrews (9) and lockplates (10) and remove the generator drive disc (11) from the alternator assembly (12).

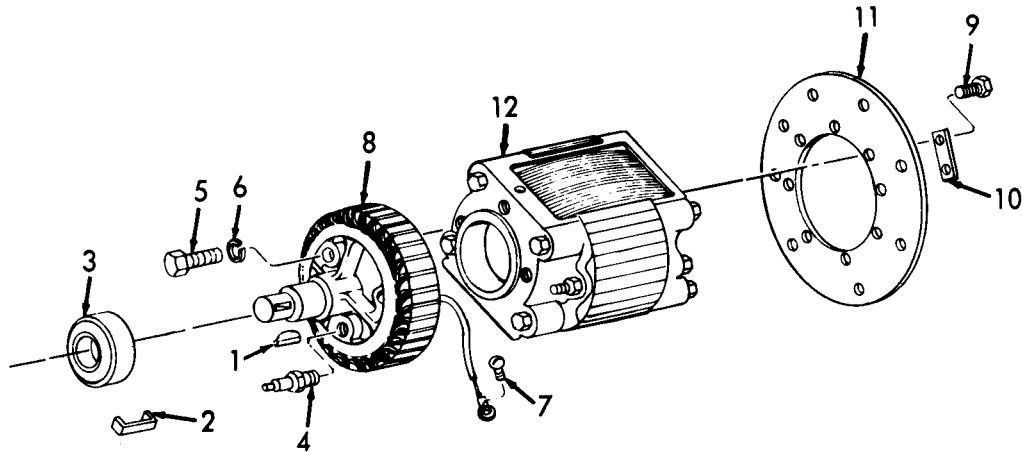

- 1. Key
- 2. Clip
- 3. Bearing
- 4. Rectifier
- 5. Capscrew
- 6. Lockwasher

- 7. Screw
- 8. Rotor ay
- 9. Capscrew
- 10. Lockplate
- 11. Disc
- 12. Alternator ay

Figure 7-12. Main generator rotor assembly, disassembly (Model MEP-017A).

(2) **Model MEP-022A.** Follow the same procedure as listed for Model MEP-017A when disas-

sembling the Model MEP-022A rotor assembly (fig. 7-13).

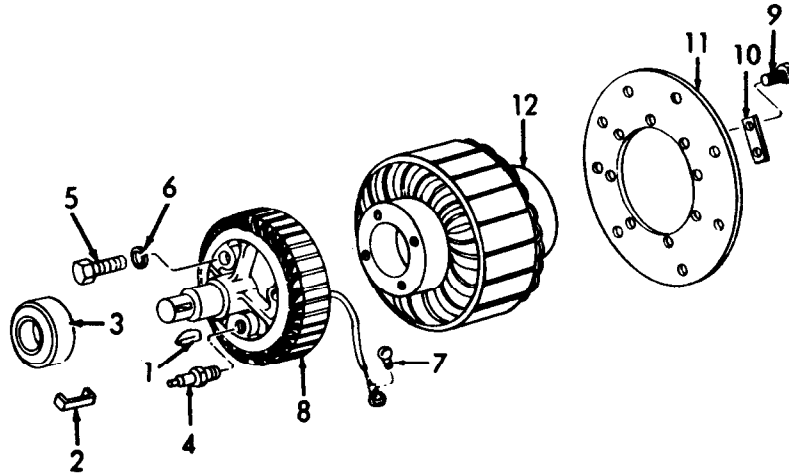

TS 6115-332-14/7-13

- 1. Key
- 2. Clip
- 3. Bearing
- 4. Rectifier
- 5. Capscrow
- 6. Lockwasher

- 7. Screw
- 8. Rotor assembly
- 9. Capscrow
- 10. Lockplate
- 11. Disc
- 12. Alternator assembly

Figure 7-13. Main generator rotor assembly, disassembly (Model MEP-022A).

c. Cleaning.

WARNING

Clean all parts in a well-ventilated area. Avoid inhalation of solvent fumes and prolonged exposure of skin to cleaning solvent. Wash exposed skin thoroughly. Dry cleaning solvent (Fed. Spec. P-D-680, Type II) used to clean parts is potentially dangerous to personnel and property. Do not use near open flame or excessive heat. Flash point of solvent is 140°F (60 °C).

(1) Clean items with cleaning solvent, Fed. Spec. P-D-680 Type II, and dry thoroughly.

d. Inspection.

(1) Inspect the fan, drive disk, and disk adapter for cracks and defective threads.

(2) Rotate the bearing to check for binding

and roughness. Inspect the seal and retaining clip.

(3) Inspect the rotor shaft for nicks, rust, wear, damage to the keyway, and defective internal threads on the end of the shaft.

(4) Inspect the windings and leads for evidence of overheating, deterioration of the varnish, and other damage.

(5) Inspect the rotating rectifier for broken connections and damaged diodes.

e. Repair.

(1) Replace a defective rotor assembly or component.

(2) A reusable bearing shall be carefully removed from the shaft by applying pressure to the inner race, only. A defective bearing shall be replaced.

(3) If any windings must be replaced or if imbalance is detected, balance the rotor assembly to within a value of 0.5 ounce inches.

(4) Refer to paragraph 7-13e (2) for baking data and to figures 7-14 and 7-15 for winding data.

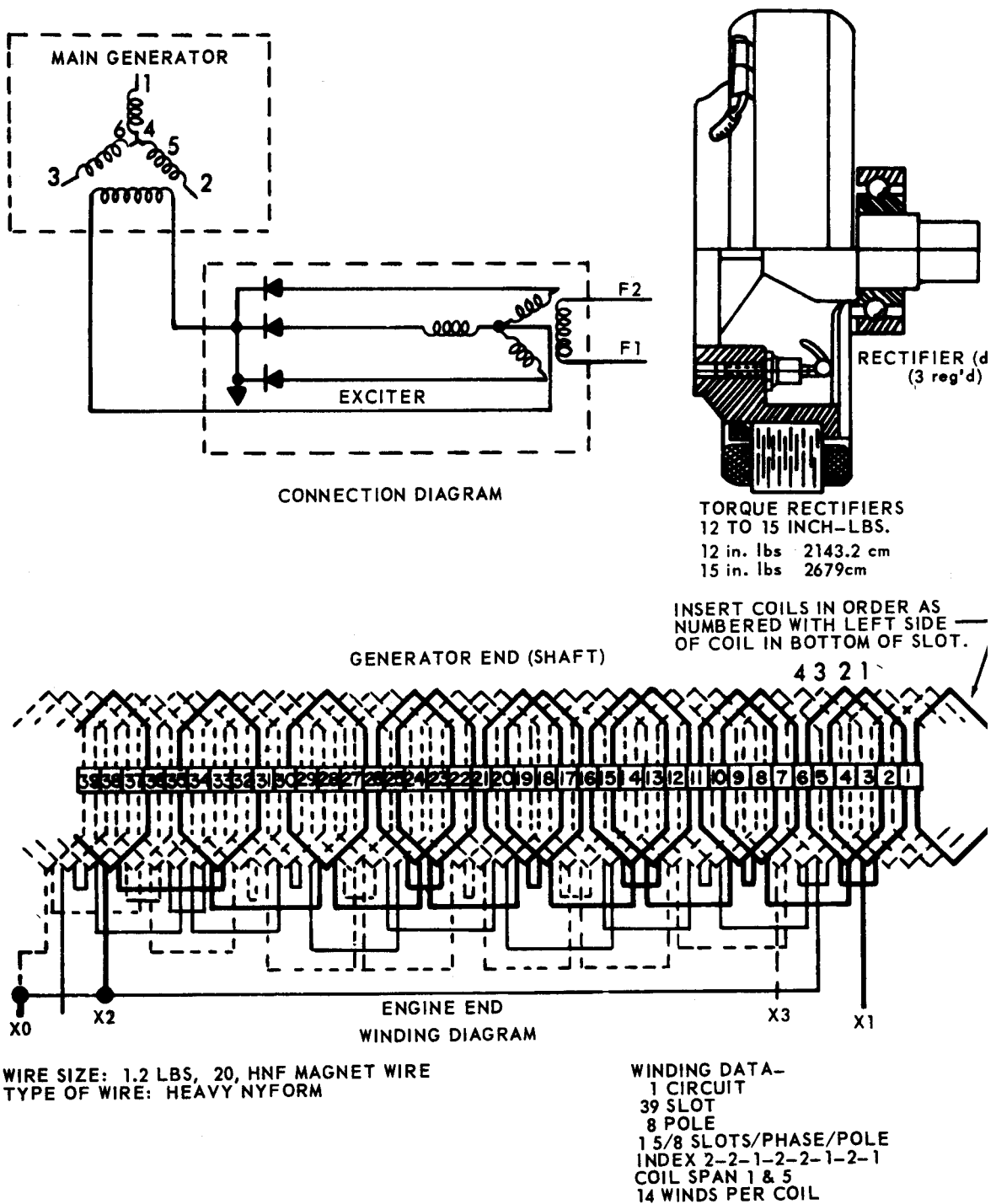
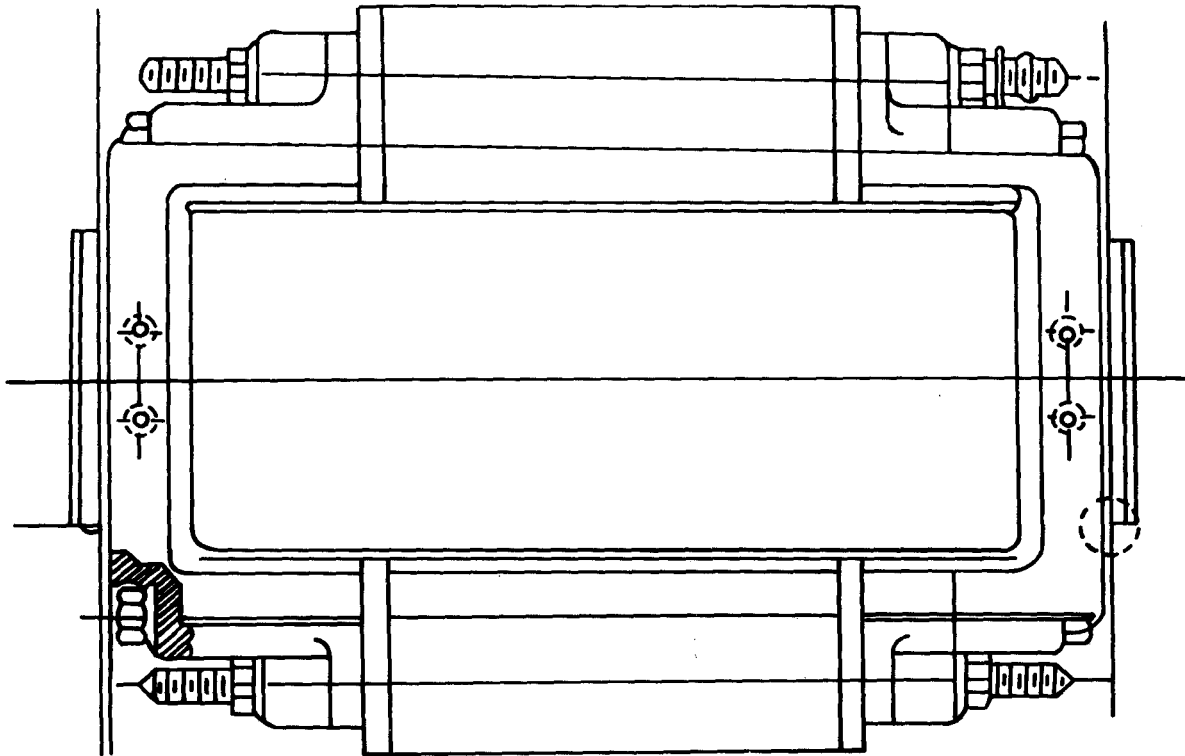

Figure 7-14. Exciter rotor, test.



Lubricate Nuts
before applying
specified torque.
All nuts shall be
torqued 120/140
in. lbs.

NUMBER OF POLES 2
NUMBER OF COILS 1

11 lbs., of No. 17
HNE Magnet Wire
Single Glass Dacron.

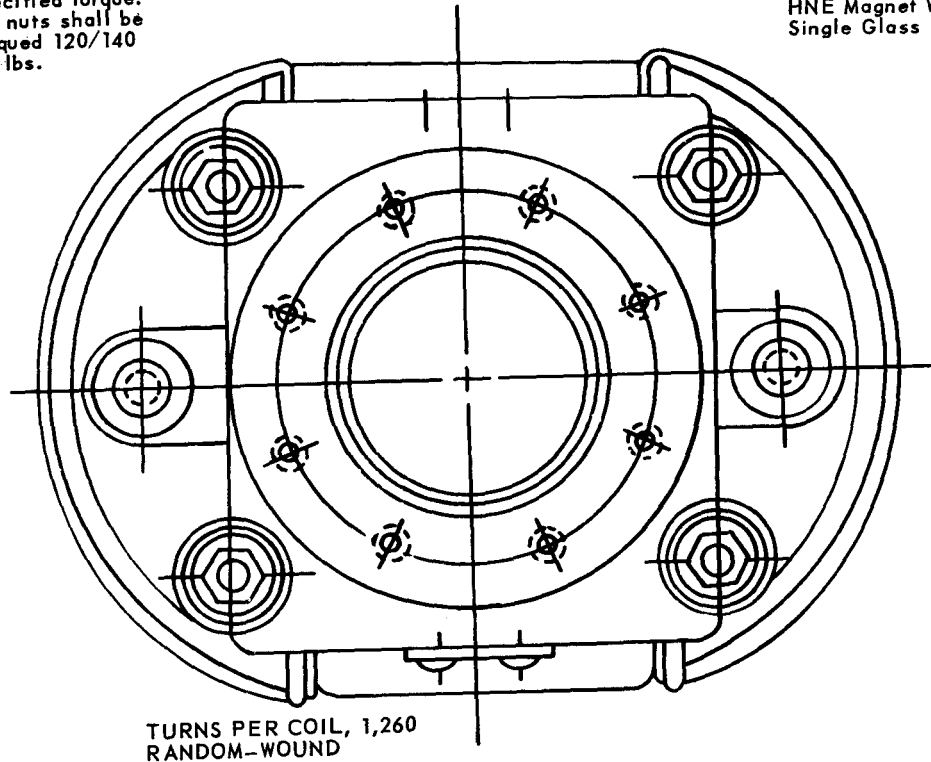

URNS PER COIL, 1,260
RANDOM-WOUND

Figure 7-15. Alternator rotor assembly, test.

f. Assembly.

(1) Model MEP-022A (fig. 7-13). Follow the same assembly procedures as Model MEP-017A, below.

(2) Model MEP-017A (fig. 7-12).

(a) Install the generator drive disc (11, fig. 7-12 or 7-13) on the alternator assembly (12) and secure with lockplates (10) and capscrews (9).

(b) Install exciter rotor assembly (8) on the alternator rotor assembly (12); secure with lead screw (7). Install the assembly. Install lockwashers (6), capscrews (5), and silicon rectifiers (4).

(c) Install ball bearing (3) and bearing clip (2).

(d) Install key (1).

g. Test.

(1) Rotating Rectifier.

(a) Tag and disconnect the rotor winding

leads. Remove the rectifier assembly from the rotor shaft. See figures 7-14 and 7-15.

(b) Check the front-to-back resistance ratio of each rectifier with an ohmmeter. The ratio should be at least 100,000/1 with the forward resistance being 10 ohms maximum.

(2) Rotors.

(a) Using the disconnected leads from the rotating rectifier, test the continuity of the rotor windings by use of a test lamp or multimeter. If continuity is not indicated, an open or short is present and shall be isolated.

(b) Use a megohmmeter to test the coil insulation. Test between the shaft and each lead on both rotors. A reading of less than 1.0 megohm indicates that the insulation is faulty.

h. Installation. Refer to paragraphs 6-2 and 6-3 or 6-4 and install the generator.

Section III. MAINTENANCE OF THE FRAME ASSEMBLY

7-15. General

The instructions contained in this section cover removal and installation of the engine front support, engine drip pan, and skid base. The skid base serves as the mounting platform for the generator set components.

7-16. Engine Support and Drip Pan

a. Removal.

(1) Remove the engine (para 6-4).

(2) Refer to figure 7-16 and the following instructions for engine support and drip pan removal.

(a) Remove the nuts, lockwashers, screws, and flatwashers securing the engine support to the skid base.

(b) Remove the engine support.

(c) Remove the nuts, lockwashers, and screws which secure the drip pan to the skid base.

(d) Remove the drip pan.

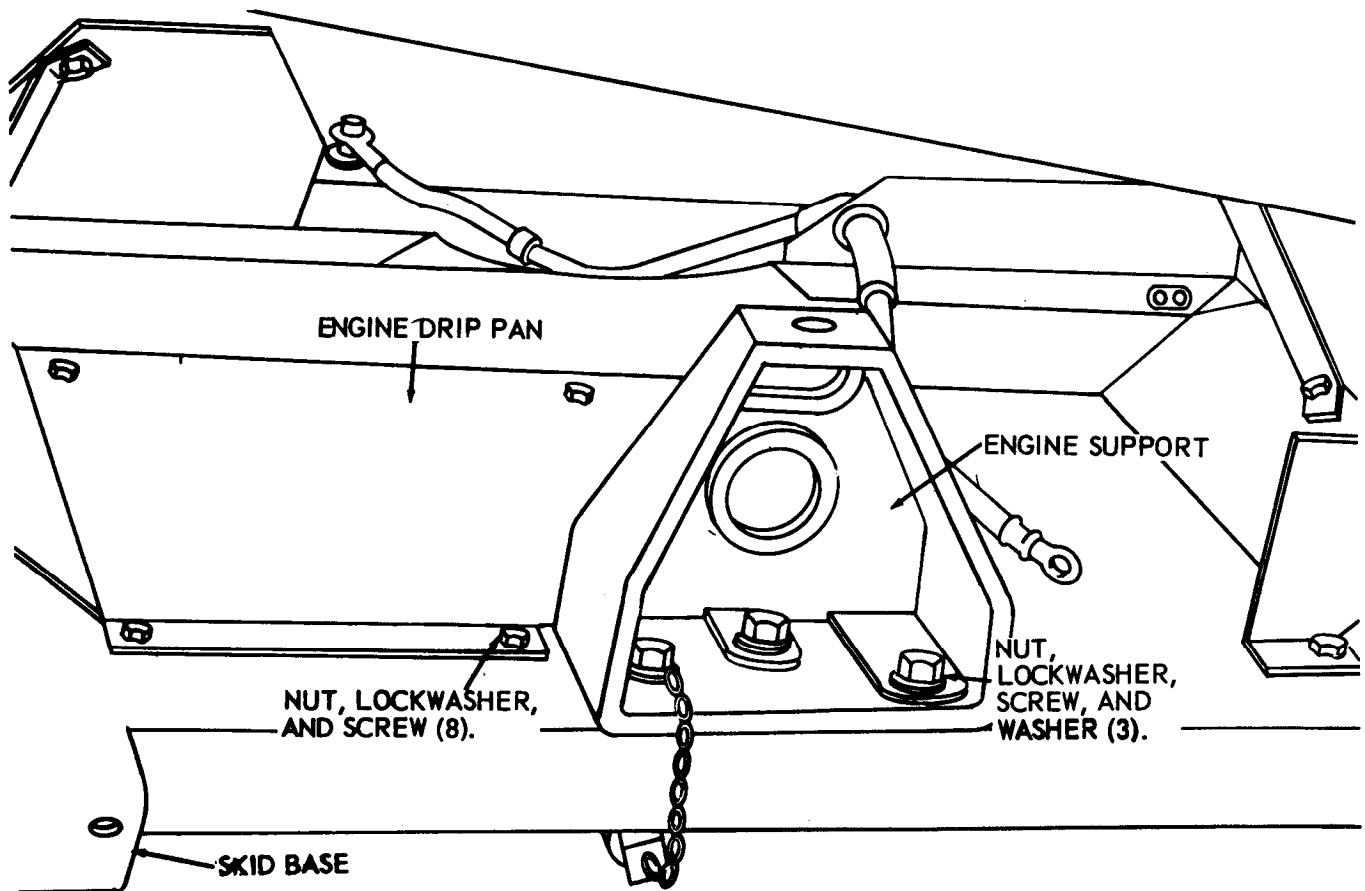

Figure 7-16. Engine Support and drip pan, removal and installation.

b. Cleaning, Inspection and Repair.

WARNING

Clean all parts in a well-ventilated area. Avoid inhalation of solvent fumes and prolonged exposure of skin to cleaning solvent. Wash exposed skin thoroughly. Dry cleaning solvent (Fed. Spec. P-D-680, Type II) used to clean parts is potentially dangerous to personnel and property. Do not use near open flame or excessive heat. Flash point of solvent is 140 °F (60 °C).

- (1) Clean items with cleaning solvent, Fed. Spec. P-D-680 Type II, and dry thoroughly.
- (2) Inspect the drip pan for cracks, dents, and

distortion. Straighten distorted or dented areas. Weld cracks and grind the welds' smooth.

(3) Inspect the engine support for cracks and other damage.

(4) Replace defective parts.

c. Installation.

(1) Secure the drip pan to the skid base with screws, lockwashers and nuts.

(2) Position the engine support in place on the skid base.

(3) Secure with flatwashers, screws, lockwashers and nuts.

(4) Install the engine (para 6-4).

7-17. Skid Base

a. Removal.

(1) Remove the engine, paragraph 6-4, and generator, paragraph 6-2 or 6-3.

(2) Remove the engine support and drip pan,

paragraph 7-16.

(3) Remove the lower battery frame, paragraph 4-23.

(4) Remove the screws, lockwashers, and nuts (fig. 7-17) securing the fuel can bracket to the skid base.

(5) Remove the fuel can bracket.

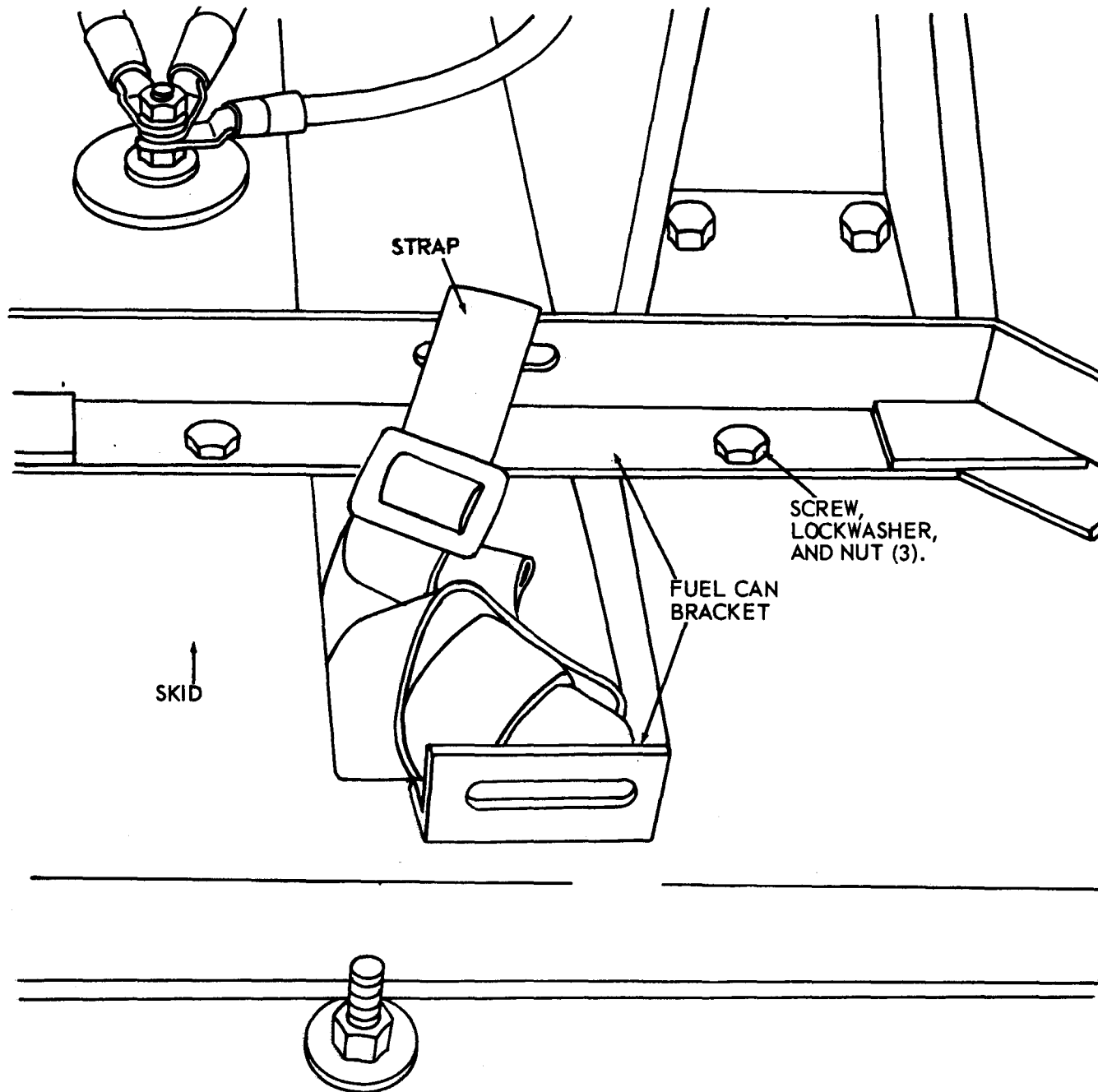

Figure 7-17. Fuel can brackets, removal and installation.

(6) Remove the fuel drum adapter and clips from the skid base by withdrawing the adapter from the two clips. Remove the clips by removing four nuts, lockwashers and screws.

b. Cleaning, Inspection and Repair.

WARNING

Clean all parts in a well-ventilated area. Avoid inhalation of solvent fumes and prolonged exposure of skin to cleaning solvent. Wash exposed skin thoroughly. Dry cleaning solvent (Fed. Spec. P-D-680, Type II) used to clean parts is potentially dangerous to personnel and property. Do not use near open flame or excessive heat. Flash point of solvent is 140°F (60°C).

(1) Clean items with cleaning solvent, Fed

Spec. P-D-680 Type II, and dry thoroughly.

(2) Inspect for cracks, breaks, broken welds, and twisted or distorted areas.

(3) Straighten distorted areas, weld cracks or broken welds, and grind the welds smooth.

(4) Replace a defective skid base.

c. Installation.

(1) To install the clips and fuel drum adapter, position the clips on the skid base and secure with screws, lockwashers, and nuts. Snap the adapter into position in the clips.

(2) Position the fuel can brackets in place on the skid base and secure with screws, lockwashers and nuts.

(3) Install the lower battery frame, paragraph 4-23.

(4) Install the engine support and drip pan, paragraph 7-16.

(5) Install the engine, paragraph 6-4, and generator, paragraph 6-2 or 6-3.

CHAPTER 8

GENERATOR SET TEST AND INSPECTION AFTER REPAIR AND OVERHAUL

Section I. GENERAL REQUIREMENTS

The activity performing the repair or overhaul is responsible for the performance of all applicable tests and inspections specified herein. Activities performing maintenance on any portion of the gen-

erator set must perform those tests and inspections required by the applicable component or system repair instruction.

Section II. INSPECTION

a. All material, repair parts, assemblies, components, welding, refinishing and other workmanship shall be sampled in accordance with MIL-STD-105D to assure compliance with standards established in this manual.

b. Overhaul inspection procedures for disassembled components and subassemblies are contained throughout the manual where applicable. All data

necessary to determine serviceability of each component or subassembly such as dimensional data, fits, tolerances, and surface finish information is contained herein.

c. Used components and repair parts recovered as products of disassembly will be examined 100% by the activity performing the repair to determine serviceability.

Section III. OPERATIONAL TESTS

a. Using the visual and operational check list (Table 8-1), visually inspect and operationally test the generator set for a minimum of four hours as follows:

- (1) 1/4 hour warm up.
- (2) 1 hour 1/2 load at .8 power factor.
- (3) 2-1/4 hours full load at .8 power factor.
- (4) 1/4 hour 125% load at .8 power factor.
- (5) 1/4 hour idle.

b. During the test period, the following operational checks will be made.

- (1) The proper operation of all components under no load and full capacity load conditions.
- (2) Proper function and adjustment of all instruments, controls and gages.
- (3) Overheating, vibration and unusual noises.
- (4) Record voltage, current, power, factor, frequency and temperature readings at the above loads.
- (5) Check operation of control and protective equipment while conducting the test run and when

the test run periods are completed and the load gradually removed, shut down the unit, after the 1/4 hour idle period.

- (6) Oil and fuel.

CAUTION

If during the operational test, excessive noise or vibration is observed or any overheating or malfunctions occur which may cause damage to the equipment, stop operation immediately until necessary repairs are made.

(7) If the malfunction is minor and will not damage the generator set, the tests may continue and defects corrected upon-completion of tests.

(8) Inspect for proper functioning, components which have been overhauled or repaired.

(9) Presence of one or more defects shall be cause for rejection until acceptable repair has been made. If repair is required to a major component, repeat the entire operational test.

Table 8-1. Visual and Operational Inspection

| Inspection Point | Condition |
|--------------------------------|--|
| 1. Data Plates | <p>a. Must be tightly affixed and legible. b. Missing plates must be replaced.</p> |
| 2. Overall | <p>a. All lines, hoses, wiring, and covers shall be properly attached and in good condition. b. All bolts and screws shall be of the proper size, have the required washers and be securely tightened. c. Grease fittings shall be undamaged.</p> |
| 3. Basic Issue Items | <p>All items must be accounted for, and in good condition, comparable to new.</p> |
| 4. Battery | <p>a. Cables and mountings should be tightened. b. Remove corrosion from battery.</p> |
| 5. Engine | <p>The engine must operate efficiently with no unusual noises and should show no signs of overheating during or after operating under full load for a period of one hour.</p> |
| 6. Fuel System | <p>a. Fuel tank must be free of contamination and rust. b. Fuel cap gasket must be in good condition and strainer must be clean. c. Fuel lines must be secure and free of sharp bends. d. There must be no evidence of leaks. e. Fuel Selector Valve. Move selector valve handle to SET TANK position and ensure engine will run. Move selector valve handle to AUXILIARY position and ensure engine will run.</p> |
| 7. Engine Electrical System | <p>a. All wiring must be adequately insulated and securely fastened. b. Cables shall be comparable to new condition and wiring harness shall be securely attached.</p> |
| 8. Control Box and Instruments | <p>a. Control box shall be securely attached. b. Gages shall be clean and legible. c. All gages, switches, and instrument panel lights must function properly. d. Gage face will be free from cracks, scratches and discoloration. Gages will be free from moisture, rust or dirt. e. Switches and controls shall operate freely. f. Wiring and wiring harness shall be attached securely. g. Ensure all gage readings are normal. Refer to chapter 2 for correct operating procedures and gage readings.</p> |

NOTE

The hourmeter, where applicable, will not be changed for the purpose of bringing it back to a zero reading.

Table 8-1. Visual and Operational Inspection (Cont'd)

| Inspection Point | Condition |
|-------------------------------------|--|
| 9. Generator | <p>a. Generator must be securely mounted and the rotor exciter shaft securely attached to the flywheel.</p> <p>b. During operation, there shall be no excessive noise or vibration.</p> <p>c. Conduct a load test to insure that the set is operable and that all meters are functioning properly.</p> <p>d. Output should be in accordance with specifications.</p> <p>e. Wiring terminals shall be clean, wiring will not be burnt, chafed, broken, cracked, cut or bare.</p> <p>f. All connections must be tight and free from dirt, rust, grease, oil, and corrosion.</p> <p>g. Switches and contacts shall not be burnt, corroded or show signs of wear.</p> <p>h. No excessive end play or vibration of rotor shaft is allowed. replace bearing if necessary.</p> <p>i. Frames shall not be crooked or broken.</p> <p>j. There shall be no missing or loose parts.</p> <p>k. The exciter rotor, stator, main rotor and stator, shall be free of any obvious or visually apparent defects. Apply a dielectric insulation or megger test when deemed necessary.</p> |
| 10. Radio Interference Suppression | <p>All interference suppression components shall be installed and securely fastened.</p> |
| 11. Skid Base, Frame and Components | <p>a. The frame and supports shall be securely attached, and shall support the generator and engine without buckling when raised, moved or skidded.</p> <p>b. Welded parts shall be free from breaks or cracks at the weld.</p> <p>c. All mounting brackets shall be securely attached.</p> <p>d. Paint shall be as specified for all components of the generator set.</p> |

APPENDIX A
REFERENCES

| | |
|---|---|
| AMF 66-1 (F) | Air Force Maintenance Management |
| DA PAM 738-750 | The Army Maintenance Management System (TAMMS) |
| TM 4700-15/1 (MC) | Maintenance Management (Marine Corps) |
| TO 35-1-4 (F) | Administrative Storage (Air Force) |
| MCOP 4450.7 (MC) | Administrative Storage (Marine Corps) |
| TO 38-1-5 (F) | Administrative Storage (Air Force) |
| TO 35C2-3 (F) | Air Force Inspection Manuals |
| TM 11275-15/1 (MC) | Marine Corps Inspection Manuals |
| TM 11-483 (A) | Radio Interference Suppression |
| TM 5-2805-258-14 (A) TO 38G2-89-21 (F) NAVFAC P-8-614-14E (N) | Operator, Organization, Direct Support and General Support Maintenance Manual, Engine, Gasoline, 10 HP, Military Standard Model 2A042-2, 2A042-3 and 2A042-4. |
| TM 5-2805-258-24P (A) TO 38G2-89-34 (F) NAVFAC P-8-614E-24P (N) | Organizational, Direct Support, General Support Maintenance Repair Parts, Special Tools for Engine, Gasoline, 10 HP, Military Standard Models 2A042-2, 2A042-3 and 2A042-4. |
| TM 5-764 (A) | Electric Motor and Generator Repair |
| TB 740-97-2 (A) | Preservation of USATROSCOM Mechanical Equipment for Shipment and Storage |
| TO 35C2-3-1A26 (F) | AF Inspection Manual |
| TO 35C2-3-1-426WC-3-2-1 (F) | AF Preventive Maintenance Workcards |
| TO 35-1-5 (F) | Processing and Inspection of Non-Mounted, Non-Aircraft Gasoline and Diesel Engines for Storage and Shipment |

APPENDIX A

REFERENCES – Continued

TO 34Y19-1-111 (F)

Electric Motor and General Repair

TM 5-6115-332-24P (A)
TO 35C2-3-424-24

Organizational, Intermediate (Field), Direct Support and General Support, Maintenance Repair Parts and Special Tools List (Including Depot Maintenance Repair Parts and Special Tools) Generator Set, Gasoline Engine: Air Cooled, 5KW, AC, 120/240 V Single Phase, 120/208 V 3 Phase Skid Mounted, Tubular Frame (Less Engine) Military Design MEP-017A, MEP-022A

APPENDIX B

BASIC ISSUE ITEMS LIST AND ITEMS TROOP INSTALLED OR AUTHORIZED LIST

Section I. INTRODUCTION

This Appendix lists Basic Issue Items, Items Troop Installed or Authorized which accompany the generator set and are required by the Crew/Operator for Operation, installation, or operator's maintenance.

B-2. General

This basic issue items, items troop installed or authorized list is divided into the following sections:

a. Basic Issue Items List. Not applicable.

b. Items Troop Installed or Authorized List - Section III. A list in alphabetical sequence of items which at the discretion of the unit commander may accompany the end item. but are NOT subject to be turned in with the end item.

B-3. Explanation of Columns

The following provides an explanation of col-

umns in the tabular list of Basic Issue Items List, Section II, and Items Troop Installed or Authorized, Section III.

a. Source, Maintenance and Recoverability Code(s) (SMR). Not applicable.

b. National Stock Number. This column indicates the National Stock Number assigned to the item and will be used for requisitioning purposes.

c. Description. This column indicates the Federal item name and any additional description of the item required.

d. Unit of Measure (U/M). A two character alphabetic abbreviation indicating the amount or quantity of the item upon which the allowances are based, e.g., ft, ea, pr, etc.

e. Quantity Authorized (Items Troop Installed or Authorized Only). This column indicates the quantity of the item authorized to, be used with the equipment:

Section III. ITEMS TROOP INSTALLED OR AUTHORIZED LIST

| National Stock Number | Description | U/M | Qty Auth |
|-----------------------|---|-----|----------|
| 2920-00-066-1235 | Adapter: Drum, Fuel | EA | 1 |
| 7510-00-889-3494 | Binder, Loose-Leaf U.S. Army Equipment Log Book | EA | 1 |
| 7520-00-559-9618 | Case: Maintenance and Operator's Manuals | EA | 1 |
| 5935-00-258-9156 | Connector: Plus, Slave Receptacle | EA | 1 |
| 4210-00-555-8837 | Extinguisher, Fire | EA | 1 |
| | Hose, Fuel: Auxiliary-Make from: | | |
| 4720-00-540-1962 | Hose, Bulk | FT | AR |
| 4730-00-497-4281 | Adapter, Straight | EA | 2 |
| 5975-00-878-3791 | Rod Assembly: Ground | EA | 1 |
| 5120-01-013-1676 | Hammer, Slide | EA | 1 |
| 5935-00-322-8959 | Adapter Connector | EA | 1 |
| 6115-00-945-7545 | Cover, Canvas | EA | 1 |

APPENDIX C

MAINTENANCE ALLOCATION CHART (FOR ARMY AND MARINE CORP ONLY)

Section I. INTRODUCTION

C-1. General

a. This section provides a general explanation of all maintenance and repair functions authorized at various maintenance levels.

b. Section II - designates overall responsibility for the performance of maintenance functions on the identified end item or component and the work measurement time required to perform the functions by the designated maintenance level. The implementation of the maintenance functions upon the end item or component will be consistent with the assigned maintenance functions.

c. Section III - lists the tools and test equipment required for each maintenance function as referenced from Section II.

C-2. Explanation of Columns in Section H

a. Column 1. Group Number. Column 1 lists group numbers to identify related components, assemblies, sub-assemblies, and modules with their next higher assembly. The applicable groups are listed in the MAC in disassembly sequence beginning with the first group removed.

b. Column 2. Component/Assembly. This column contains the noun names of components, assemblies, sub-assemblies and modules for which maintenance is authorized.

c. Column 3. Maintenance Functions. This column lists the functions to be performed on the item listed in column 2. The maintenance functions are defined as follows:

(1) **Inspect.** To determine serviceability of an item by comparing its physical, mechanical, and/or

electrical characteristics with established standards through examination.

(2) **Test.** To verify serviceability and detect incipient failure by measuring the mechanical or electrical characteristics of an item and comparing those characteristics with prescribed standards.

(3) **Service.** Operating required periodically to keep an item in proper operating condition, i.e., to clean (decontaminated), to preserve, to drain, to paint, or to replenish fuel, lubricants, hydraulic fluids, or compressed air supplies.

(4) **Adjust.** To maintain within prescribed limits, by bringing into proper or exact position, or by setting the operating characteristics to specified parameters.

(5) **Align.** To adjust specified variable elements of an item to bring about optimum or desired performance.

(6) **Calibrate.** To determine and cause corrections to be made or to be adjusted on instruments or test measuring and diagnostic equipments used in precision measurement. Consists of comparison of two instruments, one of which is a certified standard of known accuracy, to detect and adjust any discrepancy in the accuracy of the instrument being compared.

(7) **Install.** The act of emplacing, seating, or fixing into position an item, part of module (component or assembly) in a manner to allow the proper functioning of an equipment or system.

(8) **Replace.** The act of substituting a serviceable like type part, sub-assembly, or module (component or assembly) for an unserviceable counterpart.

(9) **Repair.** The application of maintenance services (inspect, test, service, adjust, align, calibrate, or replace) or other maintenance actions (welding, grinding, riveting, straightening, facing, remachining or resurfacing) to restore serviceability to an item by correcting specific damage, fault, malfunction, or failure in a part, sub-assembly, module (component or assembly), end item, or system.

(10) **Overhaul.** That maintenance effort (service/action) necessary to restore an item to a completely serviceable/operational condition as prescribed by maintenance standards (i.e., DMWR) in appropriate technical publications. Overhaul is normally the highest degree of maintenance performed by the Army. Overhaul does not normally return an item to a like new condition.

(11) **Rebuild.** Consists of those services/actions necessary for the restoration of unserviceable equipment to a like new condition in accordance with original manufacturing standards. Rebuild is the highest degree of materiel maintenance applied to Army Equipment. The rebuild operation includes the act of returning to zero those age measurements (hours/miles, etc.) considered in classifying Army Equipment/Components.

d. Column 4. Maintenance Category. This column is made up of sub-columns for each category of

maintenance. Work time figures are listed in these sub-columns for the lowest level of maintenance authorized to perform the function listed in Column 3. These figures indicate the average active time required to perform the maintenance function at the indicated category of maintenance under typical field operating conditions.

e. Column 5. Tools and Equipment. This column is provided for referencing by code, the common tool sets (not individual tools) special tools, test and support equipment required to perform the designated function.

C-3. Explanation of Columns in Section III

a. Column 1. Reference Code. This column consists of an Arabic number listed in sequence from Column 5 of Section II. The number references the tool sets, special tools and test equipment requirements.

b. Column 2. Maintenance Category. This column shows the lowest category of maintenance authorized to use the special tools or test equipment.

c. Column 3. Nomenclature. This [column lists the name or identification of the common tool sets, special tools or test equipment.

d. Column 4. National/NATO Stock No. (NSN). This column is provided for the NSN of common tools sets, special tools and test equipment listed in the Nomenclature column.

Section II. MAINTENANCE ALLOCATION CHART
For
Generator Set
NSNS 6115-00-017-8240,6115-00-017-8241

| (1) GROUP NUMBER | (2) COMPONENT/ ASSEMBLY | (3) MAINTENANCE FUNCTION | (4) MAINTENANCE CATEGORY * | | | | | (5) TOOLS AND EQUIPMENT | (6) REMARKS |
|---------------------|--------------------------------------|---------------------------------------|-------------------------------|------------|---------------------------|---|-------|-------------------------------|----------------|
| | | | UNIT | | INTERMEDIATE | | DEPOT | | |
| | | | C | O | F | H | D | | |
| 01 | ENGINE ASSEMBLY — MIL-STD MDL, 2A042 | Replace | | | 1.0 | | | | |
| | | | | | REFER TO TM 5-2805-258-14 | | | | |
| 02 | FUEL SYSTEM Adapter, Fuel Can | Inspect Replace | ** 0.1 | | | | | | |
| | Fittings, Fuel Lines | Inspect Replace | 0.1 | 0.1 | | | | | |
| | Strap, Fuel Can | Inspect Replace | 0.1 0.1 | | | | | | |
| | Hose Assembly, Fuel | Inspect Replace | 0.1 | 0.1 | | | | | |
| | Can, Fuel Supply | Inspect Replace | 0.1 0.1 | | | | | | |
| | Valve, Fuel Selector | Inspect Replace | 0.1 | 0.2 | | | | | |
| 03 | ELECTRICAL SYSTEM | | | | | | | | |
| | Cable Assembly, Battery | Inspect Replace Repair | 0.1 | 0.1 0.2 | | | | | |
| | Frame, Top, Hold-Down | Inspect Replace Repair | 0.1 | 0.2 0.3 | | | | 5-1 | |
| | Battery: Storage | Inspect Test Service Replace | 0.1 0.1 | 0.2 0.2 | | | | 1-B | |
| | Cable Assembly, Starter | Inspect Replace Repair | 0.1 | 0.2 0.3 | | | | | |
| | Receptacle Assembly, Slave | Inspect Replace Repair | 0.1 | 0.2 0.3 | | | | | |
| 04 | CONTROL BOX ASSEMBLY | | | | | | | | |
| | Box Assembly, Control | Inspect Replace Repair | 0.1 | 0.6 | 0.8 | | | 2-B | |

*SUBCOLUMNS ARE AS FOLLOWS

C-OPERATOR/CREW:
H-GENERAL SUPPORT:

O-ORGANIZATIONAL
D-DEPOT

F-DIRECT SUPPORT

* Indicates Worktime (Manhours) Required

Section II. MAINTENANCE ALLOCATION CHART (Cont'd)
For
Generator Set
NSNS 6115-00-017-8240, 6115-00-017-8241

| (1) GROUP NUMBER | (2) COMPONENT/ ASSEMBLY | (3) MAINTENANCE FUNCTION | (4) MAINTENANCE CATEGORY * | | | | | (5) TOOLS AND EQUIPMENT | (6) REMARKS |
|------------------------|--------------------------------|--------------------------------|-------------------------------|-----|--------------|-------|-----|-------------------------------|----------------|
| | | | UNIT | | INTERMEDIATE | DEPOT | | | |
| | | | C | O | F | H | D | | |
| | Lamp, Incandescent | Inspect | 0.1 | | | | | | |
| | | Replace | 0.1 | | | | | | |
| | Light Assembly, Panel | Inspect | 0.1 | | | | | | |
| | | Replace | | 0.2 | | | | | |
| | Meters | Inspect | | 0.1 | | | 2-B | | |
| | | Test | | 0.2 | | | | | |
| | | Replace | | 0.2 | | | | | |
| | Switchs | Inspect | | 0.1 | | | | | |
| | | Test | | 0.2 | | | 2-B | | |
| | | Replace | | 0.2 | | | | | |
| | Resistor, Variable | Inspect | | 0.1 | | | | | |
| | | Test | | 0.1 | | | 2-B | | |
| | | Replace | | 0.2 | | | | | |
| | Meter, Frequency Transducer | Inspect | | 0.1 | | | | | |
| | | Test | | 0.1 | | | 2-B | | |
| | | Replace | | 0.2 | | | | | |
| | Switch, Output Selector | Inspect | | | 0.1 | | | | |
| | | Test | | | 0.5 | | | | |
| | | Replace | | | | | | | |

*SUBCOLUMNS ARE AS FOLLOWS

C-OPERATOR/CREW:
H-GENERAL SUPPORT:

O-ORGANIZATIONAL
D-DEPOT

F-DIRECT SUPPORT

* Indicates Worktime (Manhours) Required

Section II. MAINTENANCE ALLOCATION CHART (Cont'd)
For
Generator Set
NSNS 6115-00-017-8460, 6115-00-017-8241

| (1) GROUP NUMBER | (2) COMPONENT/ ASSEMBLY | (3) MAINTENANCE FUNCTION | (4) MAINTENANCE CATEGORY* | | | | | (5) TOOLS AND EQUIPMENT | (6) REMARKS |
|------------------------|-------------------------------|--------------------------------|------------------------------|-----|--------------|-----|----------|-------------------------------|----------------|
| | | | C | O | INTERMEDIATE | | DEPOT | | |
| | | | | | F | H | | | |
| 05 | Bracket, Control Box | Inspect | 0.1 | | | | | | |
| | | Replace | | 0.1 | | | | | |
| | Panel Assembly, Control | Repair | | 0.2 | | | | 5-I | |
| | | Inspect | 0.1 | | | | | | |
| | GENERATOR ASSEMBLY | Replace | | | 0.5 | | | | |
| | | Repair | | 0.5 | | | | | |
| | Generator Assembly | Inspect | | | | 0.2 | | | |
| | | Test | | 0.2 | | | | 2-B | |
| | | Replace | | | 1.0 | | | | |
| | Rotor Assembly | Repair | | | | | 2.0 | 2-B, 3-B | |
| | | Inspect | | | 0.2 | | | | |
| | | Test | | | 0.2 | | | 2-B | |
| | Frame Assembly, Exciter | Replace | | | 1.0 | | | 2-B | |
| | | Repair | | | | | 1.0 | 2-B, 3-B | |
| | | Inspect | | | | | 0.2 | | |
| | Housing Assembly | Test | | | | | 0.3 | 2-B | |
| | | Replace | | | | | 0.5 | | |
| Repair | | | | | | 1.0 | 2-B, 3-B | | |
| Housing, Generator | Inspect | | | 0.2 | | | | | |
| | Test | | | 0.3 | | | 2-B | | |
| | Replace | | | 0.8 | | | 2-B, 3-B | | |
| Stator Assembly | Repair | | | | | 1.0 | 3-B, 5-I | | |
| | Inspect | | | 0.1 | | | | | |
| | Replace | | | 1.0 | | 2.0 | | | |
| Fan, Cooling | Repair | | | | | | 5-I | | |
| | Inspect | | | 0.3 | | | | | |
| | Test | | | 0.3 | | | 2-B | | |
| Grille, Air Intake | Replace | | | | | 2.0 | | | |
| | Repair | | | | | 2.0 | 3-B | | |
| | Inspect | | | 0.1 | | | | | |
| Bearing, Shaft | Replace | | | 0.8 | | | | | |
| | Inspect | | | 0.1 | | | | | |
| | Replace | | | 0.2 | | | | | |
| Disk, Rotor Drive | Repair | | | 0.2 | | | 4-H | | |
| | Inspect | | | 0.5 | | | 5-I | | |
| | Replace | | | 0.5 | | | | | |
| Disk, Rotor Drive | Inspect | | | 0.2 | | | | | |
| | Replace | | | 0.8 | | | | | |

*SUBCOLUMNS ARE AS FOLLOWS:

C-OPERATOR/CREW;
H-GENERAL SUPPORT;

O-ORGANIZATIONAL;
D-DEPOT

F-DIRECT SUPPORT;

Section II. MAINTENANCE ALLOCATION CHART (Cont'd)
For
Generator Set
NSNS 6115-00-017-8460, 6115-00-017-8241

| (1) GROUP NUMBER | (2) COMPONENT/ ASSEMBLY | (3) MAINTENANCE FUNCTION | (4) MAINTENANCE CATEGORY* | | | | | (5) TOOLS AND EQUIPMENT | (6) REMARKS |
|------------------------|-------------------------------|--------------------------------|------------------------------|------------|--------------|-------|---|-------------------------------|----------------|
| | | | UNIT | | INTERMEDIATE | DEPOT | | | |
| | | | C | O | F | H | D | | |
| 06 | Adapter, Disk Starter | Inspect Replace | | | 0.2 0.8 | | | | |
| | FRAME ASSEMBLY | | | | | | | | |
| | Guard, Frame | Inspect Replace Repair | 0.1 | 0.2 | 0.3 | | | 5-I | |
| | Bracket, Lifting | Inspect Replace | 0.1 | 0.1 | | | | | |
| | Stud, Grounding | Inspect Replace | 0.1 | 0.1 | | | | | |
| | Base Assembly, Skid | Inspect Replace Repair | 0.1 | 1.5 1.0 | | | | 5-I | |
| | Box Assembly, Tool | Inspect Replace Repair | 0.1 | | 0.2 | | | 5-I | |

*SUBCOLUMNS ARE AS FOLLOWS:

C-OPERATOR/CREW;
H-GENERAL SUPPORT;

O-ORGANIZATIONAL;
D-DEPOT

F-DIRECT SUPPORT;

All data on page C-7 deleted

TM 5-6115-332-14

P-8-614-14

TO 35C2-3-424-1

Section III. TOOLS, TEST AND SUPPORT EQUIPMENT REQUIREMENTS

| REFERENCE CODE | MAINTENANCE LEVEL | NOMENCLATURE | NATIONAL STOCK NO. |
|----------------|-------------------|---------------------------------------|--------------------|
| 1-B | O | Tester, Battery, Electrolyte solution | 6630-00-171-5126 |
| 2-B | O | Multimeter | 668 |
| | | | or equal |
| 3-B | O | Ohmmeter (megger) | 6625-00-581-2466 |
| | | | or equal |
| 4-H | F | Puller Kit | 5180 -00-711 |
| | | | or equal |
| 5-1 | O | Torch outfit, cutting and welding | 34 |
| | | | or equal |

ALPHABETICAL INDEX

| | Paragraph | Page |
|---|-----------|------|
| A | | |
| AC Voltmeter (M6) | 4-33 | 4-52 |
| Cleaning, Inspection and Repair | 4-33b. | 4-53 |
| Installation | 4-33c. | 4-53 |
| Testing..... | 4-33a. | 4-52 |
| Testing..... | 4-33d. | 4-53 |
| Administrative Storage..... | 1-7 | 1-2 |
| Air Force..... | 1-7b. | 1-2 |
| Army..... | 1-7a. | 1-2 |
| Marine Corps..... | 1-7c. | 1-2 |
| Air Cleaner Service..... | 4-11 | 4-14 |
| Ammeter Phase Selector Switch (S2)..... | 4-36 | 4-53 |
| Cleaning, Inspection and Repair..... | 4-36b. | 4-53 |
| Installation..... | 4-36c. | 4-53 |
| Removal..... | 4-36a. | 4-53 |
| | 4-36d. | 4-53 |
| B | | |
| Basic Issue List and Items Troop Installed or | | |
| Authorized List | B-1 | B-1 |
| Battery | 3-13 | 3-14 |
| Inspection | 3-13a. | 3-14 |
| Service..... | 3-13b. | 3-14 |
| Battery and Battery Frame..... | 4-23 | 4-44 |
| Cleaning, Inspection and Repair..... | 4-23c. | 4-45 |
| Installation..... | 4-23d. | 4-46 |
| Removal..... | 4-23b. | 4-44 |
| Testing..... | 4-23a. | 4-44 |
| Battery Cables, Starter Cable and Grommet, | | |
| and Terminal Stud..... | 4-22 | 4-42 |
| Cleaning, Inspection and Repair..... | 4-22b. | 4-44 |
| Installation..... | 4-22c. | 4-44 |
| Removal..... | 4-22a. | 4-42 |
| Battery Charging Ammeter (M3)..... | 4-29 | 4-51 |
| Cleaning, Inspection and Repair..... | 4-29b. | 4-51 |
| Installation..... | 4-29c. | 4-51 |
| Removal..... | 4-29a. | 4-51 |
| Testing..... | 4-29d. | 4-51 |
| Blowtorch..... | 2-4 | 2-17 |
| Description..... | 2-4a. | 2-17 |
| Operation and Service..... | 2-4b. | 2-17 |
| C | | |
| Circuit Breaker (CB)..... | 4-41 | 4-56 |
| Cleaning..... | 4-41b. | 4-56 |
| Installation..... | 4-41c. | 4-57 |
| Removal..... | 4-41a. | 4-56 |
| Control Box Assembly..... | 3-14 | 3-14 |
| Cleaning..... | 3-14b. | 3-14 |
| Inspection..... | 3-14c. | 3-15 |
| Installation..... | 3-14d. | 3-15 |
| Removal..... | 3-14a. | 3-14 |
| Control Box..... | 6-1 | 6-1 |
| Installation..... | 6-1b | 6-1 |
| Removal..... | 6-1a. | 6-1 |
| Control Box Bracket..... | 4-45 | 4-61 |
| Cleaning, Inspection and Repair..... | 4-45b. | 4-63 |
| Installation..... | 4-45c. | 4-63 |
| Removal..... | 4-45a. | 4-61 |
| Controls and Instruments..... | 2-1 | 2-1 |
| Controls and Instruments..... | 2-1b. | 2-1 |
| General..... | 2-1a. | 2-1 |

ALPHABETICAL INDEX (CON'T)

| | Paragraph | Page |
|---|-----------|------|
| Control Relays (K1, K2, K3 and K4) | 4-42 | 4-57 |
| Cleaning, Inspection and Repair | 4-42b. | 4-58 |
| Installation | 4-42d. | 4-59 |
| 4-42a. | | 4-57 |
| Testing | 4-42c. | 4-58 |
| Current Indicator Meter (M5) | 4-35 | 4-53 |
| Cleaning, Inspection and Repair | 4-35b. | 4-53 |
| Installation | 4-35c. | 4-53 |
| Removal | 4-35a. | 4-53 |
| 4-35d. | | 4-53 |
| Current Transformer (CT) and Resistors | 7-5 | 7-3 |
| Cleaning and Impaction | 7-5c. | 7-4 |
| Installation | 7-5e. | 7-4 |
| On-Equipment Testing | 7-5a. | 7-3 |
| Repair | 7-5d. | 7-4 |
| Removal | 7-5b. | 7-4 |
| D | | |
| Description | 1-9 | 1-3 |
| Control Boxes | 1-9d. | 1-7 |
| Engines | 1-9b. | 1-7 |
| General | 1-9a. | 1-3 |
| Generators | 1-9c. | 1-7 |
| Destruction of Materiel to Prevent Enemy Use | | |
| (A, MC) | 1-6 | 1-2 |
| Fire | 1-6a. | 1-2 |
| Gunfire | 1-6b. | 1-2 |
| Mechanical Destruction | 1-6c. | 1-2 |
| Detailed Lubrication Information (Operator/Crew) | 3-4 | 3-3 |
| Detailed Lubrication Information (Organizational | | |
| Maintenance) | 4-10 | 4-14 |
| Differences Between Models | 1-11 | 1-13 |
| Direct and General Support Maintenance Repair | | |
| Parts | 5-2 | 5-1 |
| Dismantling for Movement | 4-4 | 4-12 |
| Handling Equipment | 4-4b. | 4-12 |
| Preparation for Movement | 4-4a | 4-12 |
| E | | |
| Electrical System | 3-12 | 3-14 |
| Emergency Stop-Run Switch (S6) | 4-30 | 4-51 |
| Cleaning, Inspection and Repair | 4-30b. | 4-51 |
| Installation | 4-30c. | 4-51 |
| Removal | 4-30a. | 4-51 |
| 4-30d. | | 4-51 |
| Engine | 6-4 | 6-7 |
| Installation | 6-4b. | 6-12 |
| Removal | 6-4a | 6-7 |
| Engine Support and Drip Pan | 7-16 | 7-24 |
| Cleaning, Inspection and Repair | 7-16b. | 7-25 |
| Installation | 7-16c. | 7-25 |
| Removal | 7-16a. | 7-24 |
| Equipment Conversion | 4-3 | 4-11 |
| Explanation of Columns in the Tabular List | | |
| of Consumable Maintenance and Operating | | |
| Supplies | 3-2 | 3-1 |
| Component Application | 3-2a. | 3-1 |
| Description | 3-2c. | 3-1 |
| National Stock Number | 3-2b. | 3-1 |
| Notes | 3-2f. | 3-1 |
| Quantity Required for Eight Hours Operation | 3-2e. | 3-1 |
| Quantity Required for Initial Operation | 3-2d. | 3-1 |

ALPHABETICAL INDEX (CON'T)

| | Paragraph | Page |
|--|------------|------|
| F | | |
| Frame Assembly | 3-16 | 3-15 |
| Frequency Converter | 7-2 | 7-1 |
| Cleaning and Inspection | 7-2d. | 7-2 |
| General | 7-2a. | 7-1 |
| Installation | 7-2f. | 7-2 |
| Repair | 7-2e. | 7-2 |
| Removal | 7-2c. | 7-1 |
| Testing | 7-2b. | 7-1 |
| Frequency Meter (M) | 4-34 | 4-53 |
| Cleaning, Inspection and Repair | 4-34b | 4-53 |
| Installation | 4-34c. | 4-53 |
| Removal | 4-34a. | 4-53 |
| Testing | 4-34d. | 4-53 |
| Fuel System | 3-11 | 3-13 |
| Installation | 3-11b. (2) | 3-13 |
| Removal | 3-11b. (1) | 3-13 |
| Fuseholder (XF) (Model MEP-017A) | 4-40 | 4-54 |
| Cleaning, Inspection and Repair | 4-40b. | 4-56 |
| Installation | 4-40c. | 4-56 |
| Removal | 4-40a. | 4-54 |
| G | | |
| General Disassembly Procedures | 5-6 | 5-8 |
| General Methods Used to Attain Proper Suppression | 4-17 | 4-41 |
| General Instructions for Use of Multimeters | 4-16 | 4-17 |
| If the AC Volta Scale is Used | 4-16d. | 4-32 |
| Introduction | 4-16a. | 4-17 |
| Using the DC Volts Scale | 4-16c. | 4-26 |
| Using the Ohms Scale | 4-16b. | 4-19 |
| General Repair and/or Replacement Criteria | 5-7 | 5-8 |
| Generator Assembly | 3-15 | 3-15 |
| Inspection | 3-15a. | 3-15 |
| Service | 3-15b. | 3-15 |
| Generator (Model MEP-017A) | 6-2 | 6-2 |
| Installation | 6-2b. | 6-4 |
| Removal | 6-2a. | 6-2 |
| Generator (Model MEP.022A) | 6-3 | 6-4 |
| Installation | 6-3b. | 6-7 |
| Removal | 6-3a. | 6-4 |
| Ground Stud Terminal | 4-49 | 4-67 |
| Cleaning, Inspection and Repair | 4-49b. | 4-68 |
| Installation | 4-49c. | 4-68 |
| Removal | 4-49a. | 4-67 |
| Guard Frame | 4-47 | 4-64 |
| Cleaning, Inspection and Repair | 4-47b. | 4-65 |
| Installation | 4-47c. | 4-65 |
| Removal | 4-47a. | 4-64 |
| I | | |
| Inspecting and Servicing the Equipment | 4-1 | 4-1 |
| Inspecting the Equipment | 4-1a. | 4-1 |
| Servicing the Equipment | 4-1b. | 4-1 |
| Installation | 4-2 | 4-1 |
| Procedure | 4-2a | 4-1 |
| Revetment Construction | 4-2b. | 4-4 |
| Interference Suppression Components | 4-18 | 4-41 |

ALPHABETICAL INDEX (CON'T)

| | Paragraph | Page |
|---|-----------|------|
| L | | |
| Levels of Maintenance Accomplishments | 1-5 | 1-2 |
| Lifting Eye and Lifting Bracket | 4-48 | 4-65 |
| Cleaning, Inspection and Repair | 4-48b | 4-67 |
| Installation | 4-48c | 4-67 |
| Removal | 4-48a | 4-65 |
| Limited Applicability | 1-2 | 1-1 |
| Load Terminal Board (TBI) | 7-8 | 7-8 |
| Cleaning, Inspection and Repair | 7-8b | 7-8 |
| Instillation | 7-8c | 7-9 |
| Removal | 7-8a | 7-8 |
| M | | |
| Main Generator Rotor Assembly | 7-14 | 7-19 |
| Assembly | 7-14f | 7-24 |
| Cleaning | 7-14c | 7-21 |
| Disassembly | 7-14b | 7-19 |
| Inspection | 7-14d | 7-21 |
| Instillation | 7-14h | 7-24 |
| Repair | 7-14e | 7-21 |
| Removal | 7-14a | 7-19 |
| Test | 7-14g | 7-24 |
| Main Generator Stator and Housing Assembly | 7-13 | 7-12 |
| Assembly | 7-13f | 7-19 |
| Cleaning | 7-13c | 7-16 |
| Disassembly | 7-13b | 7-12 |
| Inspection | 7-13d | 7-16 |
| Instillation | 7-13h | 7-19 |
| Repair | 7-13e | 7-16 |
| Removal | 7-13a | 7-12 |
| Test | 7-13g | 7-19 |
| Maintenance Allocation Chart (For Army and Marine Corp Only) | C-1 | C-1 |
| Maintenance Forms and Records | 1-3 | 1-1 |
| Maintenance Repair Parts | 4-8 | 4-13 |
| O | | |
| Oil Drain Assembly and Muffler | 3-10 | 3-13 |
| Oil Pressure Indicator (M2) | 4-26 | 4-50 |
| Cleaning, Inspection and Repair | 4-26b | 4-50 |
| Installation | 4-26c | 4-50 |
| Removal | 4-26a | 4-50 |
| Testing | 4-26d | 4-50 |
| On-Equipment Testing | 7-12 | 7-12 |
| Exciter Field Windings | 7-12d | 7-12 |
| General | 7-12a | 7-12 |
| Rotor | 7-12c | 7-12 |
| Stator | 7-12b | 7-12 |
| Operation at High Altitudes | 2-10 | 2-20 |
| Operation in Dusty or Sandy Areas | 2-7 | 2-19 |
| Air Cleaner | 2-7d | 2-20 |
| Fuel System | 2-7b | 2-19 |
| General | 2-7a | 2-19 |
| Lubrication | 2-7c | 2-20 |
| Protection | 2-7e | 2-20 |
| Operation in Extreme Cold (Below 0° F) (-17.8C) | 2-5 | 2-19 |
| Battery | 2-5d | 2-19 |
| Electrical Systems | 2-5f | 2-19 |
| Engine Preheating | 2-5b | 2-19 |
| Fuel System | 2-5e | 2-19 |
| General | 2-5a | 2-19 |
| Lubrication | 2-5c | 2-19 |

ALPHABETICAL INDEX (CON'T)

| | Paragraph | Page |
|---|-----------|------|
| Operation in Extreme Cold (Below 0° F) (-17.8C) (Con't) | | |
| Operation | 2-5g. | 2-19 |
| Protection | 2-5h. | 2-19 |
| Operation in Extreme Heat | 2-6 | 2-19 |
| Battery | 2-6d. | 2-19 |
| Cooling | 2-6b. | 2-19 |
| General | 2-6a. | 2-19 |
| Operation | 2-6c. | 2-19 |
| Operation in Salt Water Areas | 2-9 | 2-20 |
| General | 2-9a. | 2-20 |
| Protection | 2-9b. | 2-20 |
| Operation Under Rainy or Humid Conditions | 2-8 | 2-20 |
| Electrical System | 2-8c. | 2-20 |
| Fuel System | 2-8a. | 2-20 |
| Lubrication | 2-8b. | 2-20 |
| Protection | 2-8d. | 2-20 |
| Operation Under Usual Conditions | 2-2 | 2-11 |
| General | 2-2a. | 2-11 |
| Operation and Equipment | 2-2d. | 2-17 |
| Starting | 2-2b. | 2-11 |
| Stopping | 2-2c. | 2-15 |
| Operator's Preventive Maintenance Checks | | |
| and Services | 3-6 | 3-3 |
| Operator's Troubleshooting | 3-8 | 3-5 |
| Organizational Maintenance Preventive | | |
| Maintenance Checks and Services | 4-13 | 4-15 |
| Organizational Troubleshooting | 4-15 | 4-17 |
| Outlet Receptacle (J1) (Model MEP-017A) | 4-43 | 4-59 |
| Cleaning, Inspection and Repair | 4-43b. | 4-60 |
| Installation | 4-43c. | 4-60 |
| Removal | 4-43a. | 4-59 |
| Output Selector Switch | 7-3 | 7-2 |
| Cleaning | 7-3b | 7-3 |
| Inspection | 7-3c. | 7-3 |
| Installation | 7-3f. | 7-3 |
| Repair | 7-3e. | 7-3 |
| Removal | 7-3a. | 7-2 |
| Testing | 7-3d. | 7-3 |
| P | | |
| Panel Light (XDS1 and XDS2) | 4-32 | 4-52 |
| Cleaning, Inspection and Repair | 4-32b. | 4-52 |
| Installation | 4-32c. | 4-52 |
| Removal | 4-32a. | 4-52 |
| Testing | 4-32d. | 4-52 |
| Panel Lights Switch (S7) | 4-31 | 4-51 |
| Cleaning, Inspection and Repair | 4-31b. | 4-52 |
| Installation | 4-31c. | 4-52 |
| Removal | 4-31a. | 4-51 |
| Testing | 4-31d. | 4-52 |
| Preparation for Shipment and Storage | 1-8 | 1-2 |
| Air Force | 1-8b. | 1-2 |
| Army | 1-8a. | 1-2 |
| Navy and Marine Corps | 1-8c. | 1-2 |

ALPHABETICAL INDEX (CON'T)

| | Paragraph | Page |
|---|-----------|------|
| R | | |
| References | A-1 | A-1 |
| Reinstallation After Movement | 4-5 | 4-12 |
| Relay Panel and Field Flash Switch | 7-4 | 7-3 |
| Cleaning and Inspection | 7-4b. | 7-3 |
| Installation | 7-4e. | 7-4 |
| Repair | 7-4d. | 7-4 |
| Removal | 7-4a. | 7-3 |
| Teating | 7-4c. | 7-4 |
| Remote Control Terminal Board (TB3) | 7-9 | 7-9 |
| Cleaning, Inspection and Repair | 7-9b. | 7-10 |
| Installation | 7-9c. | 7-10 |
| Removal | 7-9a. | 7-9 |
| Remote-Local Switch (S5) | 4-27 | 4-50 |
| Cleaning, Inspection and Repair | 4-27b. | 4-50 |
| Installation | 4-27c. | 4-50 |
| Removal | 4-27a. | 4-50 |
| Testing | 4-27d. | 4-50 |
| Replacement of Suppression Components | 4-19 | 4-41 |
| Cleaning, Inspection and Repair | 4-19b. | 4-41 |
| Installation | 4-19c. | 4-41 |
| Removal | 4-19a. | 4-41 |
| Reporting of Errors | 1-4 | 1-1 |
| S | | |
| Scope | 1-1 | 1-1 |
| Skid Base | 7-17 | 7-25 |
| Cleaning, Inspection and Repair | 7-17b. | 7-27 |
| Installation | 7-17c. | 7-27 |
| Removal | 7-17a. | 7-26 |
| Slave Receptacle and Bracket | 4-24 | 4-46 |
| Cleaning, Impaction and Repair..... | 4-24b. | 4-48 |
| Installation | 4-24c. | 4-48 |
| Removal | 4-24a. | 4-46 |
| Special Tools and Equipment | 4-7 | 4-13 |
| Spatial Tools and Equipment | 5-1 | 5-1 |
| Start-Stop Switch (S4) | 4-28 | 4-50 |
| Cleaning, Inspection and Repair | 4-28b. | 4-50 |
| Installation | 4-28c. | 4-51 |
| Removal | 4-28a. | 4-50 |
| Testing | 4-28d. | 4-51 |
| T | | |
| Tabulated Data | 1-10 | 1-7 |
| Base Plan | 1-100. | 1-7 |
| Data | 1-10f. | 1-8 |
| Dimensions and Weight | 1-10d. | 1-7 |
| Engine Electrical Syetem | 1-10c. | 1-7 |
| Identification | 1-10a. | 1-7 |
| Wiring Diagram | 1-10b. | 1-7 |
| Terminal Board (TB2) | 7-10 | 7-10 |
| Cleaning, Inspection and Repair | 7-10b. | 7-11 |
| Installation | 7-10c. | 7-11 |
| Removal | 7-10a. | 7-11 |
| Testing of Radio Interference Suppression | | |
| Components | 4-20 | 4-42 |
| Time Totalizing Meter (M4) | 4-25 | 4-48 |
| Cleaning, Impaction and Repair | 4-25b. | 4-49 |
| Installation | 4-25c. | 4-49 |
| Removal | 4-25a. | 4-48 |
| Toolbox | 4-50 | 4-68 |
| Cleaning, Inspection and Repair..... | 4-50b. | 4-68 |

ALPHABETICAL INDEX (CON'T)

| | Paragraph | Page |
|--------------------------------------|---------------|------|
| Toolbox(Con't)..... | | |
| Installation..... | 4-50c. | 4-68 |
| | 4-50a. | 4-68 |
| Tools and Equipment..... | 4-6 | 4-13 |
| Top Resilient Mounts..... | 4-44 | 4-60 |
| Cleaning, Inspection and Repair..... | 4-44b. | 4-61 |
| Installation..... | 4-44c. | 4-61 |
| Removal..... | 4-44a. | 4-60 |
| Troubleshooting..... | 5-4 | 5-1 |
| V | | |
| Voltage Adjusting Rheostat (R1)..... | 4-38 | 4-54 |
| Cleaning, Inspection and Repair..... | 4-38b. | 4-54 |
| Installation..... | 4-38c. | 4-54 |
| Removal..... | 4-38a. | 4-54 |
| | 4-38d. | 4-54 |
| Voltage Regulator..... | 7-6 | 7-4 |
| Cleaning and Inspection..... | 7-6c. (2) (b) | 7-5 |
| | 7-6a. | 7-4 |
| Installation..... | 7-6c. (2) (d) | 7-5 |
| | 7-6c. (2) (c) | 7-5 |
| Removal..... | 7-6c. (1) (a) | 7-5 |
| Testing..... | 7-6b. | 7-4 |
| Voltage Regulator..... | 7-6c. | 7-5 |
| Voltage Selector Switch (S3)..... | 4-37 | 4-54 |
| Cleaning, Inspection and Repair..... | 4-37b. | 4-54 |
| Installation..... | 4-37c. | 4-54 |
| Removal..... | 4-37a. | 4-54 |
| Testing..... | 4-37d. | 4-54 |
| W | | |
| Wiring Harness..... | 4-39 | 4-54 |
| Wiring and Wire Harness..... | 7-7 | 7-7 |
| General..... | 7-7a. | 7-7 |
| Testing and Replacement..... | 7-7b. | 7-7 |

By Order of the Secretaries of the Army, the Navy, and the Air Force:

Official:

BERNARD W. ROGERS
General, United States Army
Chief of Staff

J. C. PENNINGTON
Brigadier General, United States Army
The Adjutant General

D. G. ISELIN
Rear Admiral, CEC, U. S. Navy Commander
Naval Facilities Engineering Command

DAVID C. JONES, **General USAF**
Chief of Staff

JAMES J. SHEPARD, Colonel, USAF
Director of Administration

Distribution:

To be distributed in accordance with DA Form 12-25D, Operator maintenance requirements for Generator Sets, Engine Driven: 5KW 60HZ and 5 KW 400 HZ.

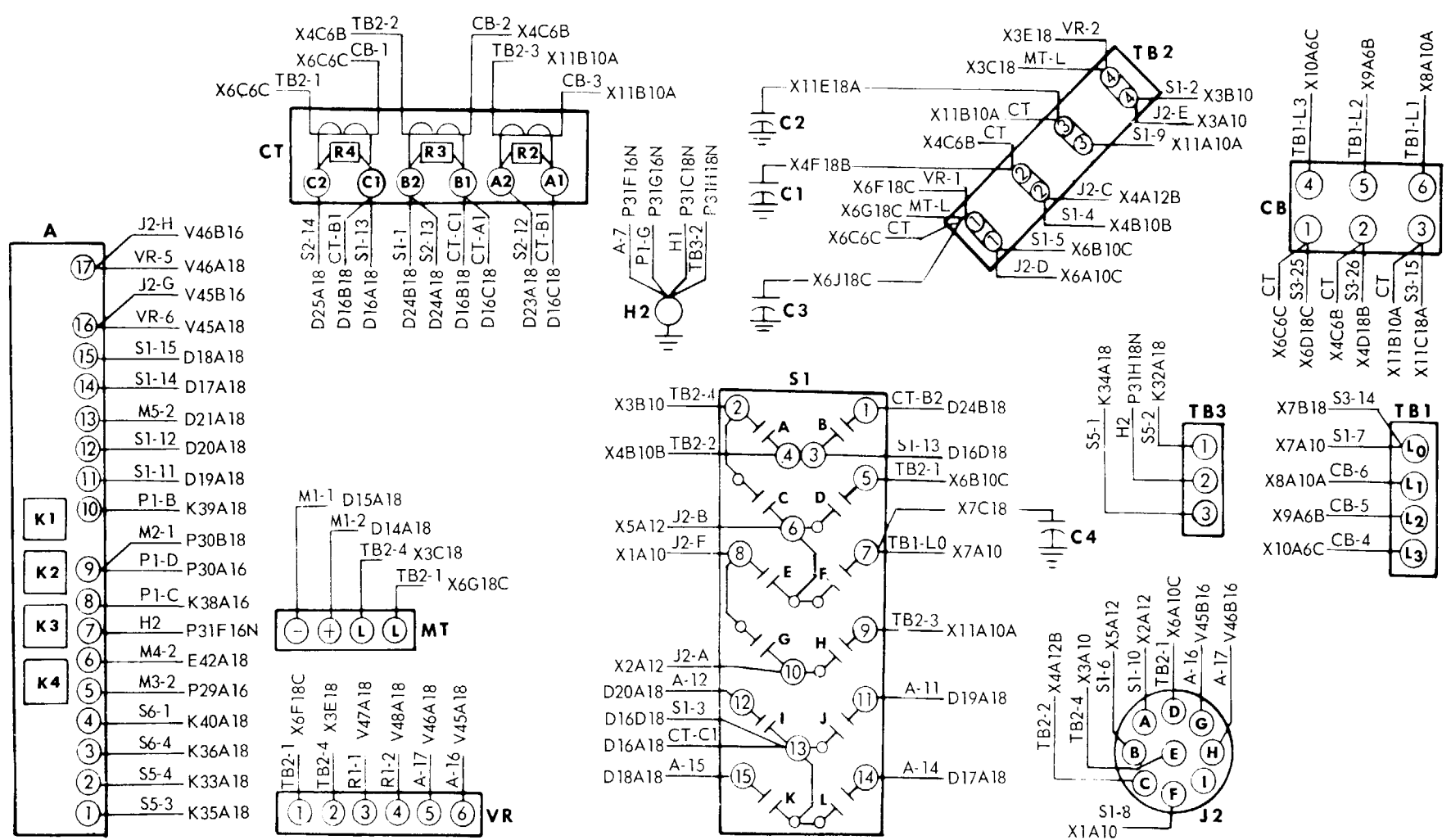

| DEVICE | LEGEND |
|----------|-----------------------------------|
| A | RELAY PANEL, CONTROL |
| BT | BATTERY, LEAD-ACID, 24V |
| C2, C3 | CAP, RAD-INTER RED, MIL-C-12889/2 |
| C1, C4 | CAP, RAD-INTER RED, MIL-C-12889/2 |
| CB | CIRCUIT BREAKER |
| CT | TRANSFORMER, CURRENT |
| DS1,2 | LAMP, INCANDESCENT, MINAT BAY, |
| G1 | GENERATOR ASSY |
| H1 | HARDWARE, GROUNDING |
| H2 | HARDWARE, GROUNDING |
| J2 | CONNECTOR, RECEPTACLE |
| J4 | RECEPTACLE, SLAVE |
| K1,2,3,4 | RELAY |
| M1 | METER, FREQ INDICATOR |
| M2 | INDICATOR, OIL PRESSURE |
| M3 | AMMETER, BATTERY CHARGE |
| M4 | METER, TIME TOTALIZING (24V) |
| M5 | METER, CURRENT INDICATOR, AC |
| M6 | VOLTMETER, AC |
| MT | CONVERTER, FREQUENCY |
| P1 | CONNECTOR, PLUG, ELECTRICAL |
| P2 | CONNECTOR, PLUG, ELECTRICAL |
| R1 | RHEOSTAT ASSY |
| R2,3,4 | RESISTOR |
| S1 | SW, OUTPUT RECONNECTION |
| S2 | SW, ROTARY |
| S3 | SW, ASSY, SELECTOR, VOLTAGE |
| S4 | SW, TOGGLE, SP(ENG START-STOP) |
| S5 | SW, TOGGLE, DP(REMOTE-LOCAL) |
| S6 | SW, TOGGLE, DP(EMER RUN-STOP) |
| S7 | SW, TOGGLE, SP(PANEL LIGHTS) |
| TB1 | TERMINAL BOARD ASSY, LOAD |
| TB2 | TERMINAL BOARD |
| TB3 | TERMINAL BOARD ASSY, REMOTE |
| VR | REGULATOR, VOLTAGE |
| XDS1,2 | LAMPHOLDER |

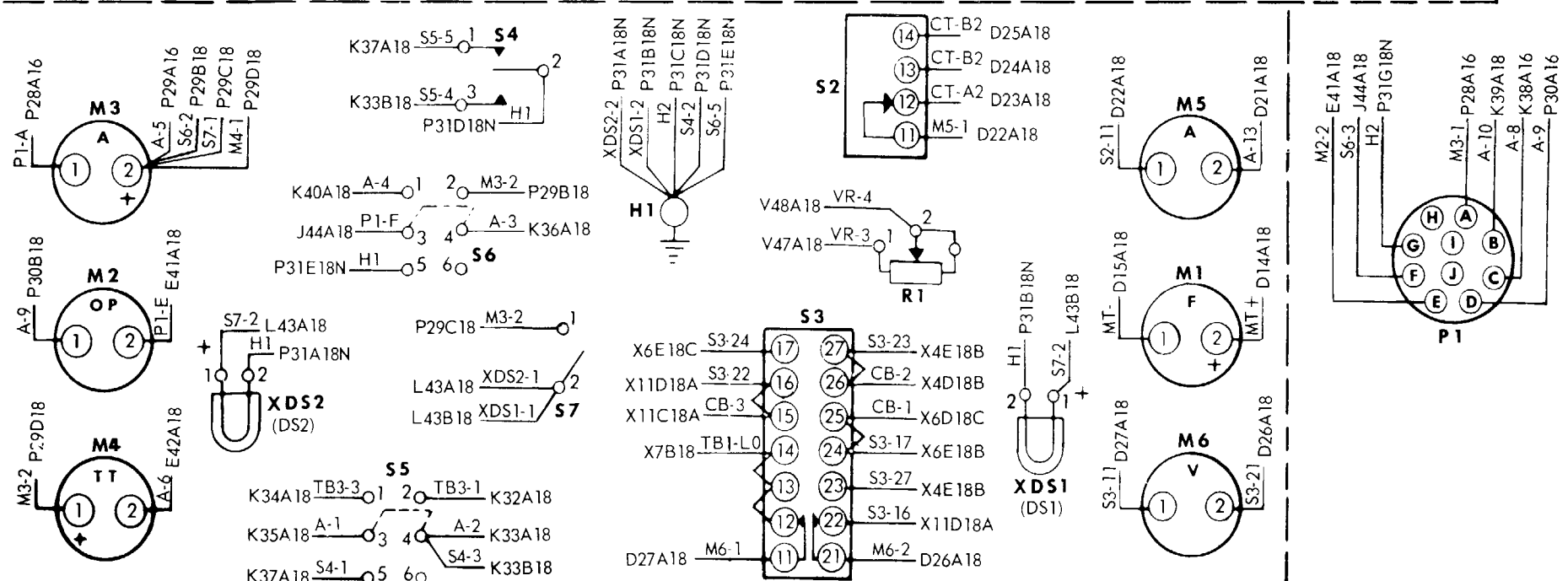

| CONNECTIONS MADE BY S1 | | (X DENOTES CLOSED CONTACT SET) | | | | | | | | | | |
|-------------------------------|-------------|--------------------------------|---|---|---|---|---|---|---|---|---|---|
| OUTPUT (SEE S1 INST PLATE) | CONTACT SET | | | | | | | | | | | |
| | A | B | C | D | E | F | G | H | I | J | K | L |
| 120/208V 3Ø L0,L1,L2,L3 | | | X | | X | X | | X | | | | X |
| 120V 3Ø L1,L2,L3 | X | | | X | | | X | X | | | | X |
| 120V1Ø L2,L3 | X | X | | X | | | X | | | X | | |
| 240V1Ø L2,L3 | | X | X | | | | X | | X | | | |

FO-1. Wiring Diagram (Model MEP-017A)

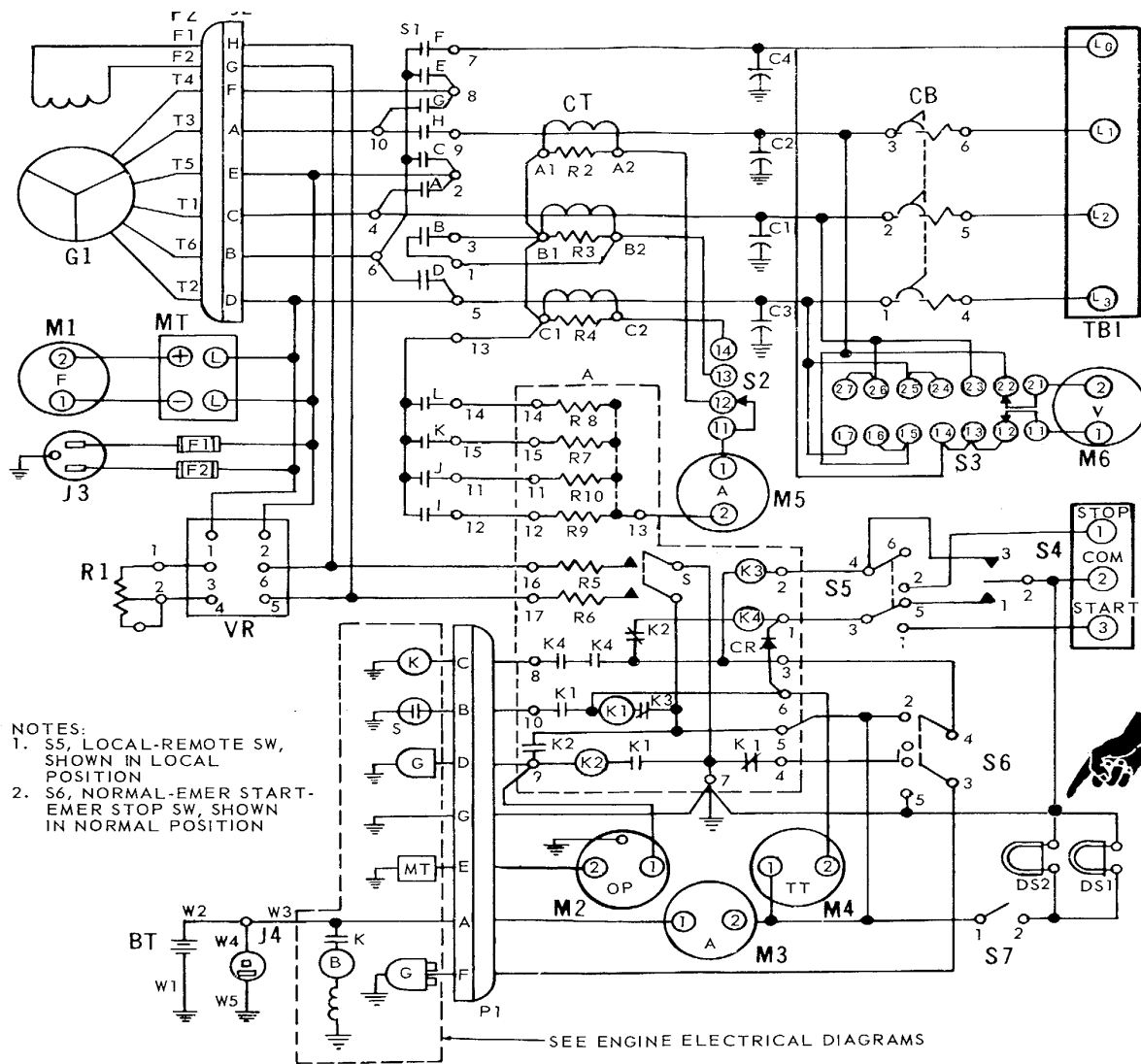

NOTES:
1. S5, LOCAL-REMOTE SW, SHOWN IN LOCAL POSITION
2. S6, NORMAL-EMER START-EMER STOP SW, SHOWN IN NORMAL POSITION

| DEVICE LEGEND | |
|---------------|----------------------------------|
| A | RELAY PANEL, CONTROL |
| BT | BATTERY, LEAD-ACID, 24V |
| C2,3 | CAPACITOR, 0.1 MFD, 500VAC/DC |
| C1,4 | CAPACITOR, 0.1 MFD, 500VAC/DC |
| CB | CIRCUIT BREAKER |
| CR | DIODE |
| CT | CURRENT TRANSFORMER |
| DS1,2 | LAMP, INCANDESCENT |
| F1,2 | FUSE, 15 AMP |
| G1 | GENERATOR |
| J2 | CONNECTOR, RECEPTACLE |
| J3 | RECEPTACLE |
| J4 | RECEPTACLE, SLAVE |
| K1, 2,3,4 | RELAY |
| M1 | METER, FREQUENCY INDICATOR |
| M2 | INDICATOR, OIL PRESSURE |
| M3 | AMMETER, BATTERY CHARGING |
| M4 | METER, TIME TOTALIZING |
| M5 | METER, CURRENT INDICATOR |
| M6 | VOLTMETER, AC |
| MT | CONVERTER, FREQUENCY |
| P1 | CONNECTOR, PLUG |
| P2 | CONNECTOR, PLUG |
| R1 | RHEOSTAT, VOLTAGE |
| R2,3,4 | RESISTOR, 305 OHMS: 1%, 3 WATT |
| R5,6 | RESISTOR, 270 OHMS: 10%, 2 WATT |
| R7 | RESISTOR, 9090 OHMS: 1%, 1 WATT |
| R8 | RESISTOR, 4320 OHMS: 1%, 1 WATT |
| R9 | RESISTOR, 7680 OHMS: 1%, 1 WATT |
| R10 | RESISTOR, 17400 OHMS: 1%, 1 WATT |
| S1 | SWITCH, FIELD FLASH |
| S2 | SWITCH, OUTPUT SELECTOR |
| S3 | SWITCH, AMMETER PHASE SELECTOR |
| S4 | SWITCH, VOLTAGE SELECTOR |
| S5 | SWITCH, START-STOP |
| S6 | SWITCH, REMOTE-LOCAL |
| S7 | SWITCH, EMERGENCY RUN-STOP |
| S7 | SWITCH, PANEL LIGHTS |
| TB1 | TERMINAL BOARD, LOAD |
| TB2 | TERMINAL BOARD |
| TB3 | TERMINAL BOARD, REMOTE CONTROL |
| VR | VOLTAGE REGULATOR |
| W1 | CABLE |
| W2 | CABLE |
| W3 | CABLE |
| W4,5 | CABLE |

| SYMBOL LEGEND | | | |
|---------------|-----------------|--|----------------------|
| | BATTERY | | CONTACT, CLOSED |
| | CAPACITOR | | CONTACT, CLOSED |
| | CIRCUIT BREAKER | | DIODE |
| | COIL | | GROUND |
| | CONTACT, OPEN | | RESISTOR, FIXED |
| | CONTACT, OPEN | | RESISTOR, ADJUSTABLE |

| CONNECTIONS MADE BY S1 (X DENOTES CLOSED CONTACT SET) | | | | | | | | | | | | |
|---|---|---|---|---|---|---|---|---|---|---|---|---|
| OUTPUT (SEE S1 INST PLATE) | A | B | C | D | E | F | G | H | I | J | K | L |
| 120/208V 3Ø LO, L1,L2,L3 | | | X | | X | X | | | | | | X |
| 120V 3Ø L1,L2,L3 | X | | | X | | | X | X | | | X | |
| 120V 1Ø L2,L3 | X | X | | X | | | X | | | X | | |
| 240V 1Ø L2,L3 | | | X | X | | | X | X | | | | |

FO-2. Generator Set, Schematic Diagram (Mode MEP-017A)

10 3/16 (SEE NOTE 2)

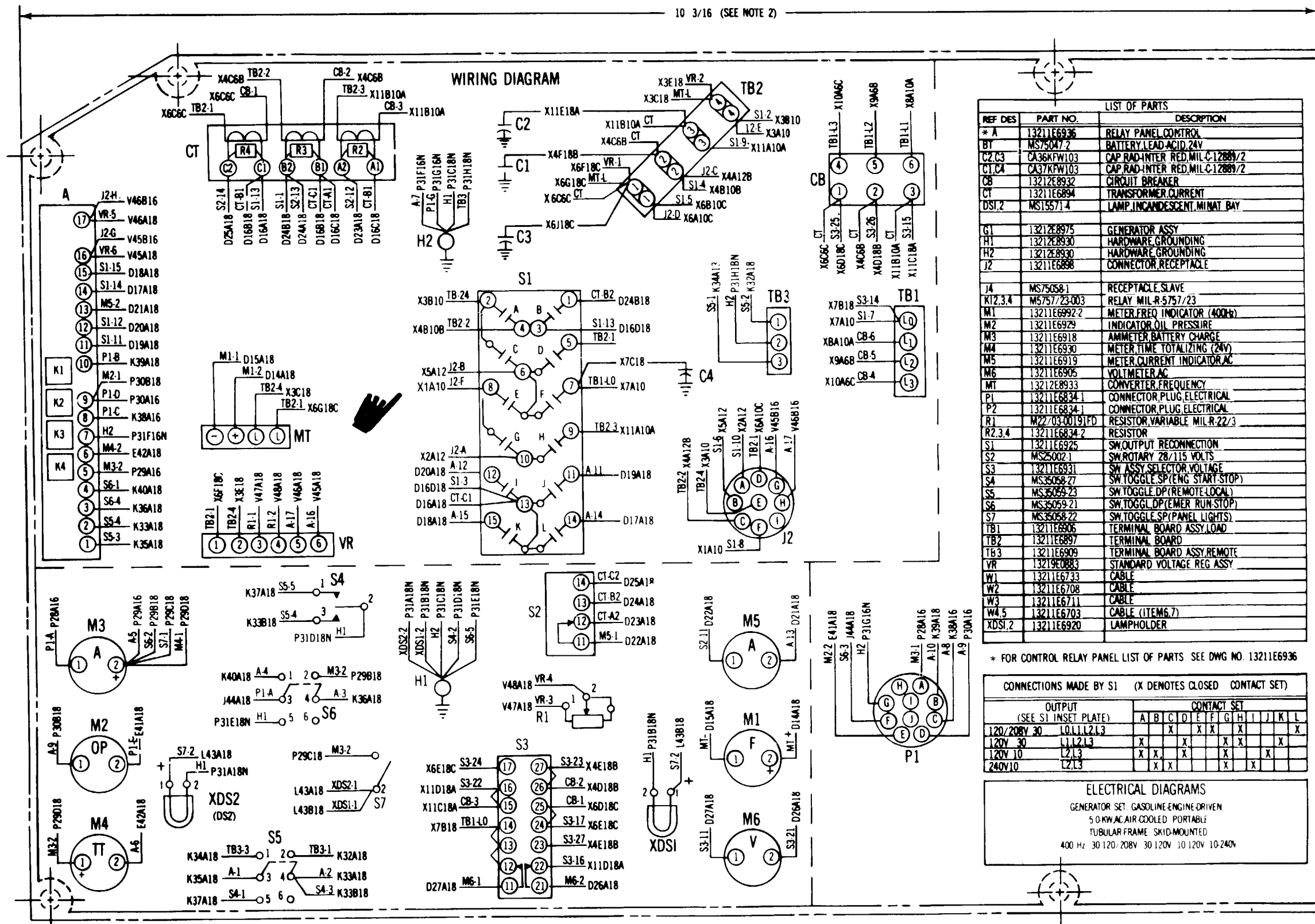

LIST OF PARTS

| REF DES | PART NO | DESCRIPTION |
|---------|--------------|---------------------------------|
| * A | 1321E6936 | RELAY PANEL CONTROL |
| BT | MS750472 | BATTERY LEAD-ACID 24V |
| C2,C3 | CA36KFW103 | CAP RAD-INTER RED.MIL-C-12889/2 |
| CT,C4 | CA37KFW103 | CAP RAD-INTER RED.MIL-C-12889/2 |
| CB | 1321E8932 | CIRCUIT BREAKER |
| CT | 1321E6894 | TRANSFORMER CURRENT |
| DSI,2 | MS155714 | LAMP INCANDESCENT MINAT BAY |
| G1 | 1321E8975 | GENERATOR ASSY |
| H1 | 1321E8930 | HARDWARE GROUNDING |
| H2 | 1321E8930 | HARDWARE GROUNDING |
| J2 | 1321E6898 | CONNECTOR RECEPTACLE |
| J4 | MS750581 | RECEPTACLE SLAVE |
| K12,3,4 | MS75723003 | RELAY MIL-R-5757/23 |
| M1 | 1321E69922 | METER FREQ INDICATOR (400Hz) |
| M2 | 1321E6929 | INDICATOR OIL PRESSURE |
| M3 | 1321E6918 | AMMETER BATTERY CHARGE |
| M4 | 1321E6930 | METER TIME TOTALIZING (24V) |
| M5 | 1321E6919 | METER CURRENT INDICATOR AC |
| M6 | 1321E6905 | VOLTMETER AC |
| MT | 1321E8933 | CONVERTER FREQUENCY |
| P1 | 1321E68341 | CONNECTOR PLUG ELECTRICAL |
| P2 | 1321E68341 | CONNECTOR PLUG ELECTRICAL |
| R1 | M227030019FD | RESISTOR VARIABLE MIL-R-22/3 |
| R2,3,4 | 1321E68342 | RESISTOR |
| S1 | 1321E6925 | SW OUTPUT RECONNECTION |
| S2 | MS20021 | SW ROTARY 28/115 VOLTS |
| S3 | 1321E6931 | SW ASSY SELECTOR VOLTAGE |
| S4 | MS3505827 | SW TOGGLE SP (ENG START-STOP) |
| S5 | MS3505823 | SW TOGGLE DP (REMOTE LOCAL) |
| S6 | MS3505921 | SW TOGGLE DP (EMER RUN-STOP) |
| S7 | MS3505822 | SW TOGGLE SP (PANEL LIGHTS) |
| TB1 | 1321E6906 | TERMINAL BOARD ASSY LOAD |
| TB2 | 1321E6897 | TERMINAL BOARD |
| TB3 | 1321E6909 | TERMINAL BOARD ASSY REMOTE |
| VR | 1321E6893 | STANDARD VOLTAGE REG ASSY |
| W1 | 1321E6733 | CABLE |
| W2 | 1321E6708 | CABLE |
| W3 | 1321E6711 | CABLE |
| W4,5 | 1321E6703 | CABLE (ITEM 6,7) |
| XDS1,2 | 1321E6920 | LAMPHOLDER |

* FOR CONTROL RELAY PANEL LIST OF PARTS SEE DWG NO. 1321E6936

CONNECTIONS MADE BY S1 (X DENOTES CLOSED CONTACT SET)

| OUTPUT (SEE S1 INSET PLATE) | CONTACT SET | A | B | C | D | E | F | G | H | I | J | K | L |
|-----------------------------|-------------|---|---|---|---|---|---|---|---|---|---|---|---|
| 120/208V 30 | L1,L2,L3 | X | X | X | X | X | X | X | X | X | X | X | X |
| 120V 30 | L1,L2,L3 | X | X | X | X | X | X | X | X | X | X | X | X |
| 120V 10 | L2,L3 | X | X | X | X | X | X | X | X | X | X | X | X |
| 240V10 | L2,L3 | X | X | X | X | X | X | X | X | X | X | X | X |

ELECTRICAL DIAGRAMS
GENERATOR SET GASOLINE-ENGINE-DRIVEN
5.0 KW AC AIR-COOLED PORTABLE
TUBULAR FRAME SKID-MOUNTED
400 Hz 30 120/208V 30 120V 10 120V 10 240V

NOTES:
1. FOR INTERPRETATION OF REFERENCE DESIGNATIONS FOR ELECTRICAL AND ELECTRONICS PARTS AND EQUIPMENTS SEE USAS Y32.16 GRAPHIC SYMBOLS FOR ELECTRICAL AND ELECTRONICS

DIAGRAMS SEE USAS Y32.2 WIRE MARKINGS SEE MIL-W-5088 (WIRING AIRCRAFT INSTALLATION OF)

2. REDUCE THIS DRAWING AS REQD TO SUPERIMPOSE PHANTOM BORDER LINES ON PLATE DRAWINGS NO 1321E8934 (2 1 REDUCTION REFERENCE)

REFERENCES:
1. FOR GEN SET GASOLINE-ENGINE-DRIVEN 5.0-KW 400 Hz AC AIR-COOLED PORTABLE TUBULAR-FRAME SKID-MOUNTED SEE DWG NO. 1321E8925
2. FOR SCHEMATIC DIAGRAM SEE DWG NO. 1321E8927
3. FOR ELECTRICAL DIAGRAM PLATE SEE DWG NO. 1321E8934

ELECTRICAL DIAGRAM PLATE (REF)

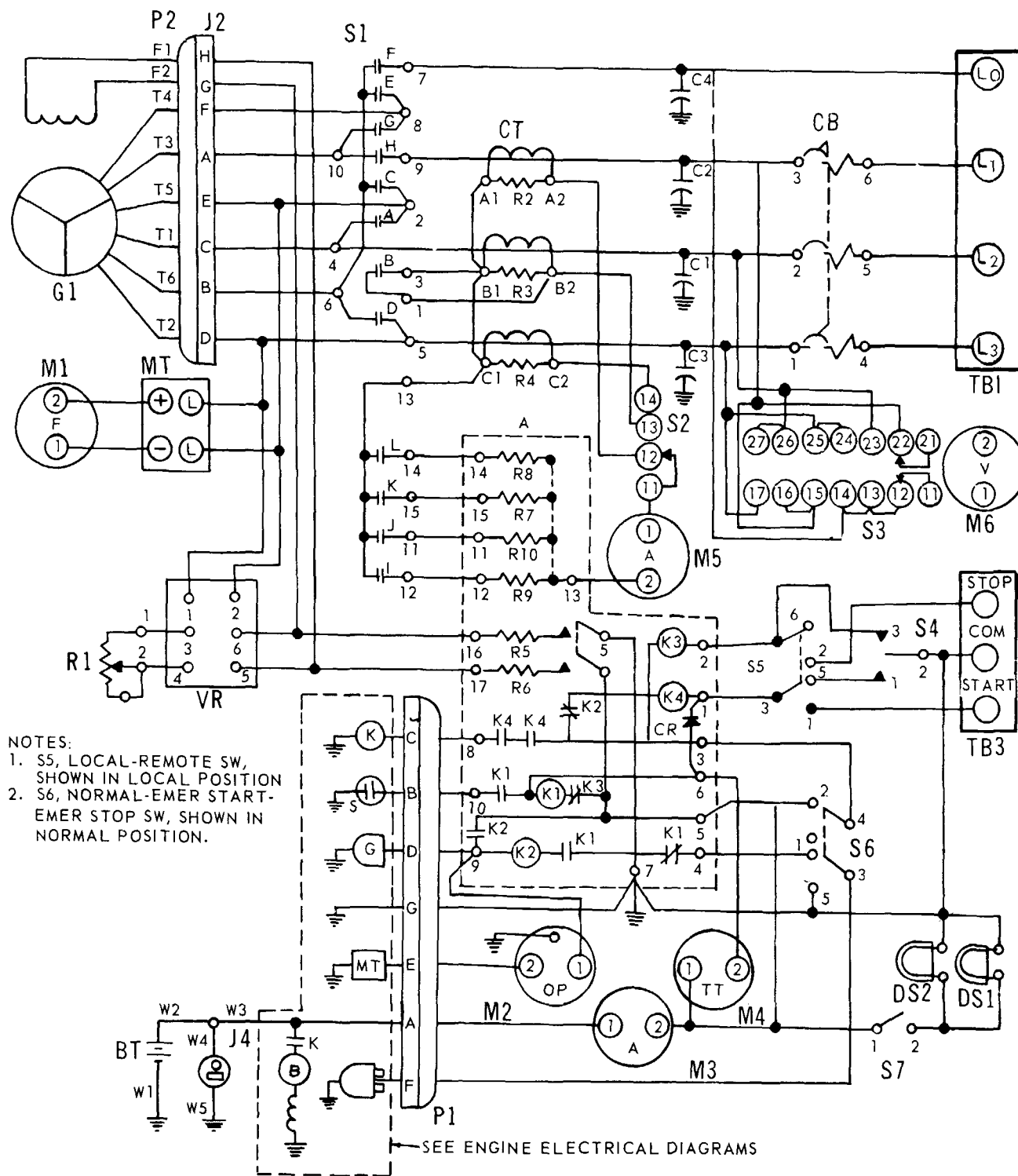

NOTES:
1. S5, LOCAL-REMOTE SW, SHOWN IN LOCAL POSITION
2. S6, NORMAL-EMER START-EMER STOP SW, SHOWN IN NORMAL POSITION.

| DEVICE LEGEND | |
|---------------|----------------------------------|
| 1A | RELAY PANEL, CONTROL |
| BT | BATTERY, LEAD-ACID, 24V |
| C2, 3 | CAPACITOR, 0.1 MFD, 500VAC/DC |
| CT, 4 | CAPACITOR, 0.1 MFD, 500V AC/DC |
| CB | CIRCUIT BREAKER |
| CR | DIODE |
| CT | CURRENT TRANSFORMER |
| DS1,2 | LAMP, INCANDESCENT |
| G1 | GENERATOR |
| J2 | CONNECTOR, RECEPTACLE |
| J4 | RECEPTACLE, SLAVE |
| K1,2,3,4 | RELAY |
| M1 | METER, FREQUENCY INDICATOR |
| M2 | INDICATOR, OIL PRESSURE |
| M3 | AMMETER, BATTERY CHARGING |
| M4 | METER, TIME TOTALIZING |
| M5 | METER, CURRENT INDICATOR |
| M6 | VOLTMETER, AC |
| MT | CONVERTER, FREQUENCY |
| P1 | CONNECTOR, PLUG |
| P2 | CONNECTOR, PLUG |
| R1 | RHEOSTAT, VOLTAGE |
| R2,3,4 | RESISTOR, 305 OHMS: 1%, 3 WATT |
| R5,6 | RESISTOR, 270 OHMS: 10%, 2 WATT |
| R7 | RESISTOR, 9090 OHMS: 1%, 1 WATT |
| R8 | RESISTOR, 4320 OHMS: 1%, 1 WATT |
| R9 | RESISTOR, 7680 OHMS: 1%, 1 WATT |
| R10 | RESISTOR, 17400 OHMS: 1%, 1 WATT |
| S | SWITCH, FIELD FLASH |
| S1 | SWITCH, OUTPUT SELECTOR |
| S2 | SWITCH, AMMETER PHASE SELECTOR |
| S3 | SWITCH, VOLTAGE SELECTOR |
| S4 | SWITCH, START-STOP |
| S5 | SWITCH, REMOTE-LOCAL |
| S6 | SWITCH, EMERGENCY RUN-STOP |
| S7 | SWITCH, PANEL LIGHTS |
| TBI | TERMINAL BOARD, LOAD |
| TB2 | TERMINAL BOARD |
| TB3 | TERMINAL BOARD, REMOTE CONTROL |
| VR | VOLTAGE REGULATOR |
| W1 | CABLE |
| W2 | CABLE |
| W3 | CABLE |
| W4,5 | CABLE |

| SYMBOL LEGEND | | | |
|---------------|-----------------|--|----------------------|
| | BATTERY | | CONTACT CLOSED |
| | CAPACITOR | | CONTACT, CLOSED |
| | CIRCUIT BREAKER | | DIODE |
| | COIL | | GROUND |
| | CONTACT, OPEN | | RESISTOR, FIXED |
| | CONTACT, OPEN | | RESISTOR, ADJUSTABLE |

| OUTPUT (SEE S1 INST PLATE) | CONNECTIONS MADE BY S1 (X DENOTES CLOSED CONTACT SET) | | | | | | | | | | | |
|-------------------------------|---|---|---|---|---|---|---|---|---|---|---|---|
| | A | B | C | D | E | F | G | H | I | J | K | L |
| 120/208V 3Ø L1, L2, L3 | | | X | X | X | X | | | | | | X |
| 120V 3Ø L1, L2, L3 | X | | | X | | | | | X | | | X |
| 120V 1Ø L2, L3 | X | X | | X | | | | | | | X | |
| 240V 1Ø L2, L3 | | X | X | | | | | | | | X | |

FO-4. Generator Set, Schematic Diagram (Model MEP-022A)

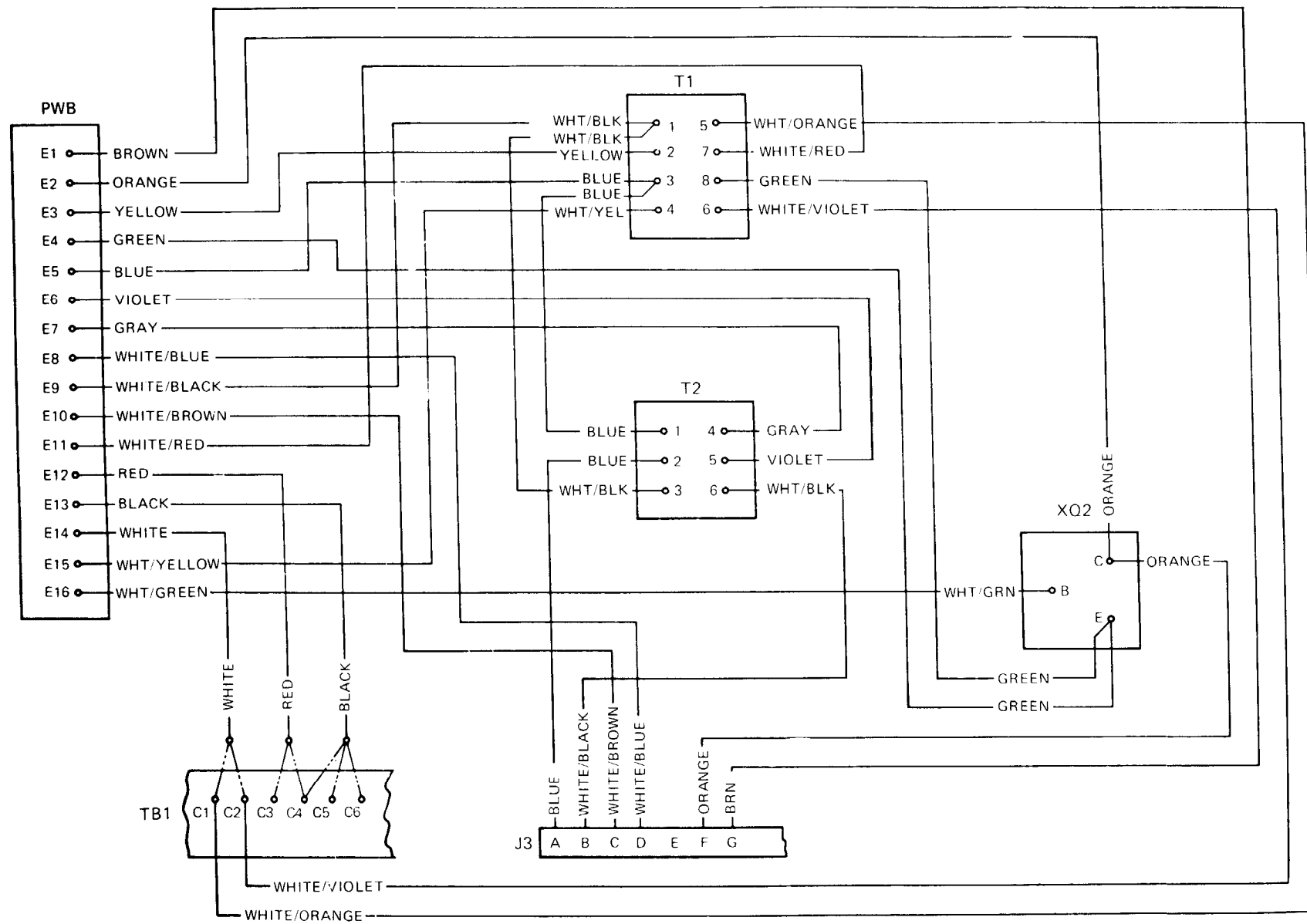

| GENERATOR SET | | | | | | | |
|---------------|---------|------------|-------------|------------|-------------|-------------|--------------|
| JUMPER WIRE | 3 kW DC | 3 kW 60 Hz | 3 kW 400 Hz | 5 kW 60 Hz | 5 kW 400 Hz | 10 kW 60 Hz | 10 kW 400 Hz |
| RED | C4 | C3 | C4 | C3 | C4 | C3 | C4 |
| BLK | C6 | C4 | C6 | C5 | C5 | C4 | C5 |
| WHT | C1 | C1 | C1 | C2 | C2 | C1 | C2 |

| COMPONENT REFERENCE LIST | | | |
|--------------------------|----------------|----------------------|----------|
| REF DES | PART NO. | DESCRIPTION | MFG CODE |
| J3 | MS 3100R20-27P | CONNECTOR | 96906 |
| PWB | 13219E0884 | PRINTED WIRING BOARD | 97403 |
| T1 | 13219E0890 | TRANSFORMER, POWER | 97403 |
| T2 | 13219E0894 | TRANSFORMER, SIGNAL | 97403 |
| TB1 | 13219E0893 | TERMINAL BOARD | 97403 |
| XQ2 | 13219E0895 | SOCKET, TRANSISTOR | 97403 |

Figure FO-5. Wiring Diagram, Standard Voltage Regulator
(FMC97403 13219E0886) TS011947

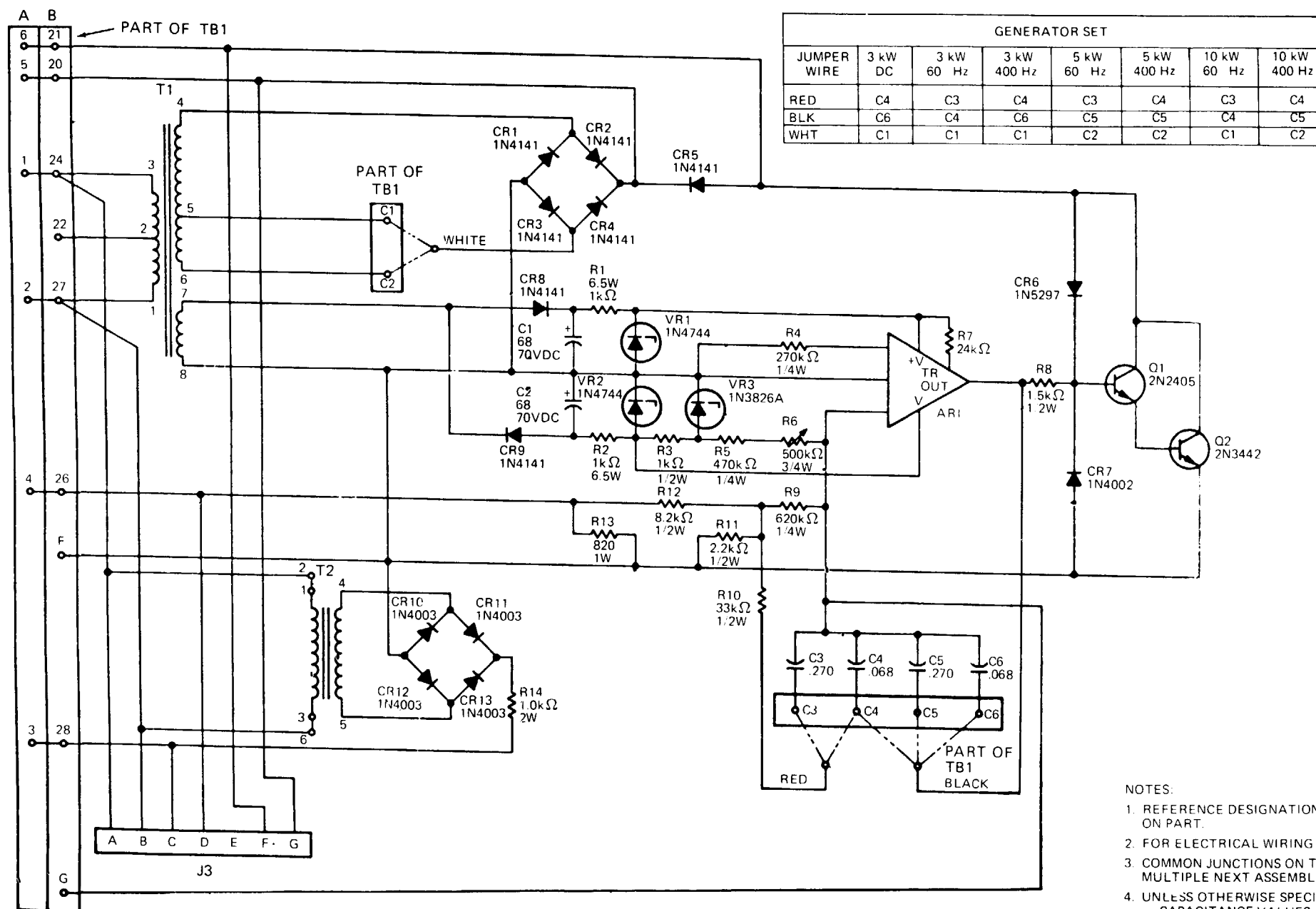

| COMPONENT REFERENCE LIST | | | |
|--------------------------|-----------------------|---------------------|--|
| MFG CODE | REF DES | PART NO. | DESCRIPTION |
| 97403 | AR1 | 13217E3701 | AMPLIFIER, SOLID STATE OPERATIONAL |
| 97403 | C1, 2 | 13219E1003 | CAPACITOR, 68 μF, 70 VDC ELECTROLYTIC, 600D586F075D4 |
| 81349 | C3, 5 | MIL-C-39014/02-0277 | CAPACITOR, .270 μF, 50 VDC, MIL-C-39014/2 |
| 81349 | C4, 6 | MIL-C-39014/02-0267 | CAPACITOR, .068 μF, 100 VDC, MIL-C-39014/2 |
| 97403 | CR1, 2, 3, 4, 5, 8, 9 | 13219E1001 | DIODE, SEMICONDUCTOR, IN4141 |
| 97403 | CR6 | 13218E5005 | DIODE, SEMICONDUCTOR, CURRENT REGULATING, IN5297 |
| 97403 | CR7 | 13219E0897 | DIODE, SEMICONDUCTOR, IN4002 |
| 97403 | CR10, 11, 12, 13 | 13219E1000 | DIODE, SEMICONDUCTOR, IN4003 |
| 96906 | J3 | MS 3100R20-27P | CONNECTOR |
| 97403 | Q1 | 13219E1002 | TRANSISTOR, 2N2405 |
| 97403 | Q2 | 13217E3700 | TRANSISTOR, POWER, 2N4347 |
| 81349 | R1, 2 | RW67V102 | RESISTOR, 1 kΩ, 6.5 W, ±5%, MIL-R-26/4 |
| 81349 | R3 | RCR20G102JM | RESISTOR, 1 kΩ, 1/2 W, ±5%, MIL-R-39008/2 |
| 81349 | R4 | RCR07G274JM | RESISTOR, 270 kΩ, 1/4 W, ±5%, MIL-R-39008/1 |
| 81349 | R5 | RCR07G474JM | RESISTOR, 470 kΩ, 1/4 W, ±5%, MIL-R-39008/1 |
| 81349 | R6 | RJ12FY504 | RESISTOR, VAR, 500 kΩ, 3/4 W, MIL-R-22097/2 |
| 81349 | R7 | RCR20G243JM | RESISTOR, 24 kΩ, 1/2 W, ±5%, MIL-R-39008/2 |
| 81349 | R8 | RCR20G152JM | RESISTOR, 1.5 kΩ, 1/2 W, ±5%, MIL-R-39008/2 |
| 81349 | R9 | RCR07G624JM | RESISTOR, 620 kΩ, 1/4 W, ±5%, MIL-R-39008/1 |
| 81349 | R10 | RCR20G333JM | RESISTOR, 33 kΩ, 1/2 W, ±5%, MIL-R-39008/2 |
| 81349 | R11 | RCR20G222JM | RESISTOR, 2.2 kΩ, 1/2 W, ±5%, MIL-R-39008/2 |
| 81349 | R12 | RCR20G822JM | RESISTOR, 8.2 kΩ, 1/2 W, ±5%, MIL-R-39008/2 |
| 81349 | R13 | RCR32G821JM | RESISTOR, 820 Ω, 1 W, ±5%, MIL-R-39008/3 |
| 81349 | R14 | RC42GF102JM | RESISTOR, 1.0 kΩ, 2 W, ±5%, MIL-R-39008/5 |
| 97403 | T1 | 13219E0890 | TRANSFORMER, POWER |
| 97403 | T2 | 13219E0894 | TRANSFORMER, SIGNAL |
| 97403 | TB1 | 13219E0893 | TERMINAL BOARD |
| 97403 | VR1, 2 | 13217E3698 | DIODE, ZENER, IN4744 |
| 81349 | VR3 | 1N3826A | DIODE, ZENER, MIL-S-19500/115 |

- NOTES:
1. REFERENCE DESIGNATIONS ARE FOR REFERENCE ONLY AND SHALL NOT APPEAR ON PART.
 2. FOR ELECTRICAL WIRING DIAGRAM, SEE 13219E0886.
 3. COMMON JUNCTIONS ON TBI REFLECT TWO NUMBERS ONLY TO ACCOMMODATE MULTIPLE NEXT ASSEMBLY USAGE.
 4. UNLESS OTHERWISE SPECIFIED: CAPACITANCE VALUES ARE IN MICROFARADS. RESISTANCE VALUES ARE IN OHMS.

Figure FO-6. Schematic Diagram, Standard Voltage Regulator
3KW, 5KW, 10KW, DC, 60, Hz, 400 Hz (FMC97403 13219E0887) TSO 11948

The Metric System and Equivalents

Linear Measure

1 centimeter = 10 millimeters = .39 inch
 1 decimeter = 10 centimeters = 3.94 inches
 1 meter = 10 decimeters = 39.37 inches
 1 dekameter = 10 meters = 32.8 feet
 1 hectometer = 10 dekameters = 328.08 feet
 1 kilometer = 10 hectometers = 3,280.8 feet

Weights

1 centigram = 10 milligrams = .15 grain
 1 decigram = 10 centigrams = 1.54 grains
 1 gram = 10 decigrams = .035 ounce
 1 dekagram = 10 grams = .35 ounce
 1 hectogram = 10 dekagrams = 3.52 ounces
 1 kilogram = 10 hectograms = 2.2 pounds
 1 quintal = 100 kilograms = 220.46 pounds
 1 metric ton = 10 quintals = 1.1 short tons

Liquid Measure

1 centiliter = 10 milliliters = .34 fl. ounce
 1 deciliter = 10 centiliters = 3.38 fl. ounces
 1 liter = 10 deciliters = 38.82 fl. ounces
 1 dekaliter = 10 liters = 2.64 gallons
 1 hectoliter = 10 dekaliters = 26.42 gallons
 1 kiloliter = 10 hectoliters = 264.18 gallons

Square Measure

1 sq. centimeter = 100 sq. millimeters = .155 sq. inch
 1 sq. decimeter = 100 sq. centimeters = 15.5 sq. inches
 1 sq. meter (centare) = 100 sq. decimeters = 10.76 sq. feet
 1 sq. dekameter (are) = 100 sq. meters = 1,076.4 sq. feet
 1 sq. hectometer (hectare) = 100 sq. dekameters = 2.47 acres
 1 sq. kilometer = 100 sq. hectometers = .386 sq. mile

Cubic Measure

1 cu. centimeter = 1000 cu. millimeters = .06 cu. inch
 1 cu. decimeter = 1000 cu. centimeters = 61.02 cu. inches
 1 cu. meter = 1000 cu. decimeters = 35.31 cu. feet

Approximate Conversion Factors

| <i>To change</i> | <i>To</i> | <i>Multiply by</i> | <i>To change</i> | <i>To</i> | <i>Multiply by</i> |
|------------------|--------------------|--------------------|--------------------|---------------|--------------------|
| inches | centimeters | 2.540 | ounce-inches | newton-meters | .007062 |
| feet | meters | .305 | centimeters | inches | 3.94 |
| yards | meters | .914 | meters | feet | 3.280 |
| miles | kilometers | 1.609 | meters | yards | 1.094 |
| square inches | square centimeters | 6.451 | kilometers | miles | .621 |
| square feet | square meters | .093 | square centimeters | square inches | .155 |
| square yards | square meters | .836 | square meters | square feet | 10.764 |
| square miles | square kilometers | 2.590 | square meters | square yards | 1.196 |
| acres | square hectometers | .405 | square kilometers | square miles | .386 |
| cubic feet | cubic meters | .028 | square hectometers | acres | 2.471 |
| cubic yards | cubic meters | .765 | cubic meters | cubic feet | 35.315 |
| fluid ounces | milliliters | 29.573 | cubic meters | cubic yards | 1.308 |
| pints | liters | .473 | milliliters | fluid ounces | .034 |
| quarts | liters | .946 | liters | pints | 2.113 |
| gallons | liters | 3.785 | liters | quarts | 1.057 |
| ounces | grams | 28.349 | liters | gallons | .264 |
| pounds | kilograms | .454 | grams | ounces | .035 |
| short tons | metric tons | .907 | kilograms | pounds | 2.205 |
| pound-feet | newton-meters | 1.365 | metric tons | short tons | 1.102 |
| pound-inches | newton-meters | .11375 | | | |

Temperature (Exact)

| | | | | |
|----|-------------|-----------------|-------------|----|
| °F | Fahrenheit | 5/9 (after | Celsius | °C |
| | temperature | subtracting 32) | temperature | |

