

# User's Manual

# MG

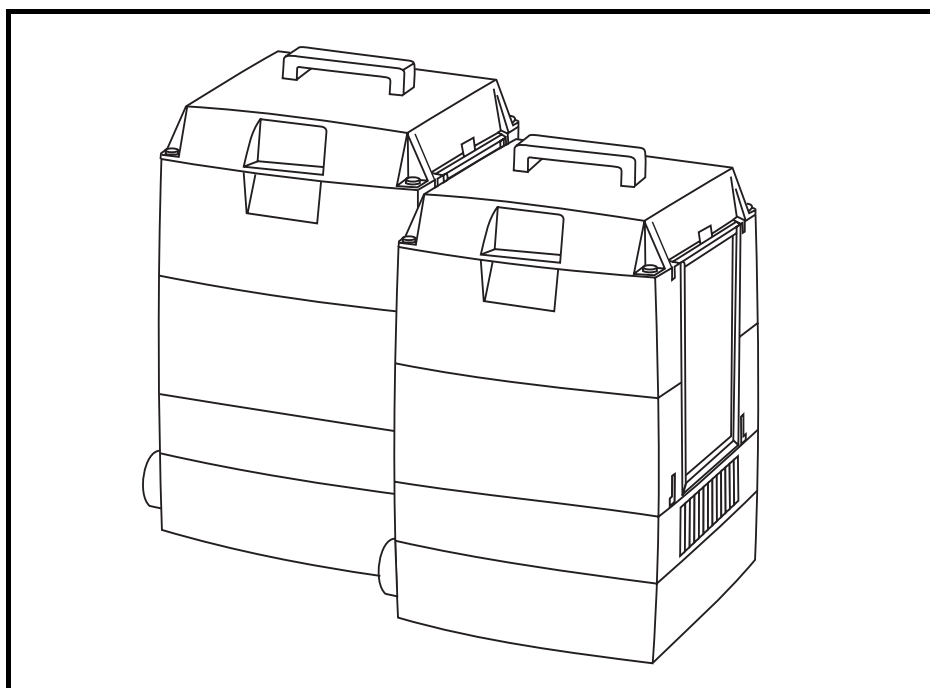

## Desiccant Dehumidifiers MG50 & MG90

Effective from serial No. 31880



# Contents

<b>Important user information</b> .....	4
<b>1. Introduction</b>	
1.1 General .....	5
1.2 About this manual .....	5
1.3 Safety and Cautions.....	5
1.4 Markings .....	6
<b>2. Installation</b>	
2.1 Safety.....	7
2.2 Packaging and delivery inspection.....	7
2.3 Storing the equipment.....	7
2.4 Location requirements .....	8
2.5 Duct/hose connections .....	8
2.5.1 General.....	8
2.5.2 Ducting and airflow adjustment .....	9
2.6 Mounting units on the Wall.....	10
2.7 Installation examples .....	11
2.8 Electrical connections .....	13
2.8.1 General.....	13
2.8.2 Safety.....	13
2.9 Connecting the humidistat .....	13
<b>3. Operation</b>	
3.1 Starting up .....	15
3.2 Emergency stop.....	15
3.3 Start .....	15
3.3.1 Manual operation.....	15
3.3.2 Automatic operation.....	15
3.4 Stopping the unit.....	16
<b>4. Maintenance</b>	
4.1 General .....	17
4.2 Safety.....	17
4.3 Maintenance schedule.....	17
<b>5. Fault finding</b>	
5.1 General .....	18
5.2 Safety.....	18
5.3 Fault localization .....	18
<b>6. Product Design Information</b>	
6.1 Product description .....	20
6.2 Principal of operation .....	20
6.3 Dimensions and service space .....	21
6.4 Capacity Diagrams.....	22
6.5 Fan Diagrams .....	22
6.6 Accessories .....	23
6.7 Technical Specifications.....	24

## Important user information

### Intended use of equipment

The MG50 & MG90 dehumidifiers are intended to be used for the dehumidification of air. All other uses of the equipment, or use which is contrary to the instructions given in this manual, can cause personal injury and/or machine damage.

### Warranty and obligations

The warranty period is 12 months from the date the equipment left our factory unless otherwise advised in writing. The warranty is limited to a free exchange complete with free freight, of faulty units or components which have failed as a result of faulty quality or defects in manufacture.

Munters guarantees that the delivered unit has undergone rigid testing to ensure that the specifications stated here are fulfilled. All claims on warranty must verify that the fault has occurred within the guarantee period, plus that the unit has been used within its operating range as stated in the specification. All claims must include the unit type and manufacturing number. This data is to be found stamped on the unit identification plate, see Section **Markings** for location.

### Note

The contents of this publication can be changed without prior notice.

This publication contains information which is protected by copyright laws. No part of this publication may be reproduced, stored in a system for information retrieval or be transmitted in any form, in any manner without Munters' written consent.

Please send any comments regarding the content of this publication to:

Munters Europe AB  
Dehumidification Division  
Technical Publications  
PO Box 434  
SE-191 24 Sollentuna  
Sweden

Tel.: +46 (8) 626 63 00  
Fax: +46 (8) 626 86 18

© Munters Europe AB 2005

### Safety

In this publication hazardous activities are indicated and preceded by the common hazard symbol.



**WARNING!** is used in this publication to indicate a possible danger that could lead to personal injury. An instruction is normally given, followed by a short explanation plus the possible effect if the instruction is not followed.



**CAUTION!** is used in this publication to indicate a possible danger that could lead to damage to the machine or other equipment and/or cause environmental damage. An instruction is normally given, followed by a short explanation plus the possible environmental effect if the instruction is not followed.

### NOTE!

Used to accentuate supplementary information that is required for problem-free use or optimal use of the unit.

### Conformity with directives and standards

The MG50 & MG90 dehumidifiers are designed and manufactured by an EN-ISO 9001 accredited development and manufacturing organization. The unit conforms with the specifications in the Machinery Directive 98/37/EEC, the Low Voltage Directive 73/23/EEC as amended by Directive 93/68/EEC and the EMC Directive 89/336/EEC as amended by Directives 92/31/EEC and 93/68/EEC. The standards applied are listed in the EC Declaration of Conformity.

# 1. Introduction

## 1.1 General

The MG50 and MG90 desiccant dehumidifiers are designed to efficiently dehumidify air. Munters has a wide range of dehumidifiers that have design parameters applicable for different usages and applications. Please contact your nearest Munters office if you have any doubt or questions regarding the actual installation.

For MG50/90 product data, *see chapter 6. Product Design Information.*

## 1.2 About this manual

This manual is written for the user of the dehumidifier and describes the installation, operation, maintenance and basic fault finding.

The information structure of the manual is built on numbered chapters and sections. Contents (page 3) gives a quick overview. The different chapters can be used separately to serve their purpose. Figures and tables are numbered in accordance with the actual chapter, e.g. figure 1-3 is picture number 3 and is found in chapter 1.

The goal of the manual is to provide the necessary information for the user to understand the unit's construction and function, and to serve as a guide during installation, operation, maintenance and basic fault finding that generally can be carried out before contacting Munters Product Service.

## 1.3 Safety and Cautions

The contents of this manual include suggested best working practices and procedures. These are issued for guidance only, they do not take precedence over the individual responsibility and/or local safety regulations. During installation and operation of this equipment it is always each individual person's responsibility to consider:

- Their own and others' personal safety.
- The safety of the unit through correct use of the equipment in accordance with the descriptions and instructions given in this manual.

Every care has been taken in the design and manufacture of the MG50 and MG90 dehumidifiers to ensure that they meet the safety requirements of the directives and standards listed in the EC Declaration of Conformity.

It is recommended to be informed about the use of safety symbols in this manual by reading the opposite page *Important user information*. The relevant safety information for this manual will be found listed early in each manual chapter.

1.4 Markings

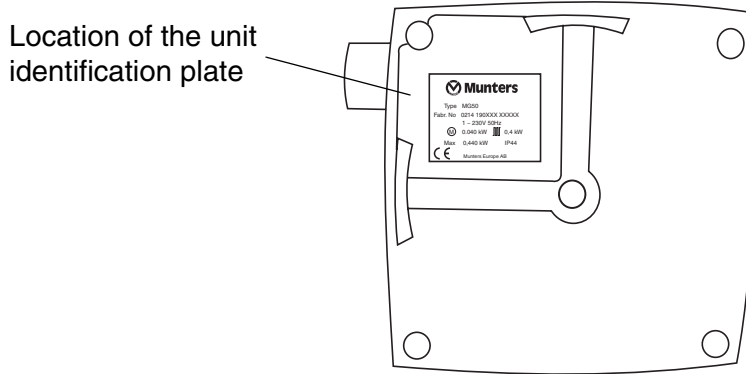

Figure 1-1. Identification plate location

The units Identification plate is located on the underneath of the dehumidifier.

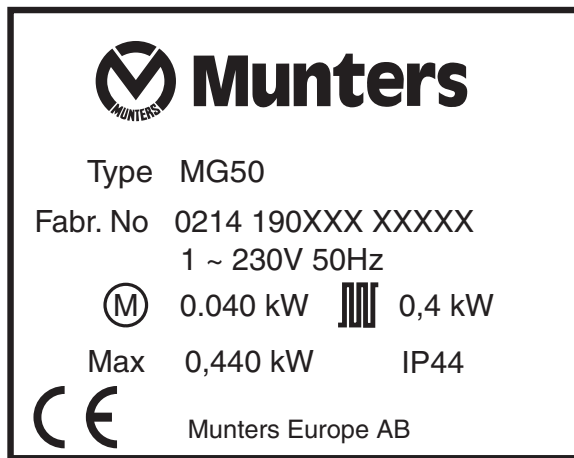

Figure 1-2. Identification plate content

## 2. Installation

### 2.1 Safety



**WARNING!** *The dehumidifier must be connected to an earthed electrical outlet.*



**WARNING!** *The unit must not be connected to other mains than specified on the unit's identification plate.*



**WARNING!** *The unit must not be opened by anyone other than trained and qualified personnel.*



**CAUTION!** *If there is a risk for freezing temperatures, the wet air ducting must be insulated.*



**CAUTION!** *We recommend that only a qualified electrician should connect the humidistat to the cable.*



**WARNING!** *All electrical equipment connections must be carried out in accordance with local regulations and by qualified personnel.*



**WARNING!** *Do not place the Wet Air side (A) and the back side (B) of the unit close to the wall or close to heat sensitive objects. Position the dehumidifier so that there is sufficient space for the air to circulate around it (see section 2.4. Location requirements).*

### 2.2 Packaging and delivery inspection

1. Check the delivery against the packaging list, consignment note or other delivery documents and check that everything is included and nothing is damaged.
2. Contact Munters immediately if delivery is not complete in order to avoid installation delays.
3. If the unit is to be put into storage, prior to installation, *see section 2.3. Storing the equipment.*

**NOTE!**

*If the installation is not to be carried out immediately after the arrival of the equipment it is advisable to leave the packing material in place on the dehumidifier, or to re-use the packaging material to provide temporary protection for the unit during later transport to the installation location and during installation.*

4. Remove all packing material from the unit, check carefully to make sure that no damage has occurred during transport.
5. Any visible damage must be reported in writing to Munters prior to the start of installation.

### 2.3 Storing the equipment

The following is important if the dehumidifier is to be stored prior to installation:

- Place the dehumidifier on a horizontal surface.

- Protect the dehumidifier from physical damage.
- Store the dehumidifier under cover and protect from dust, frost, rain and aggressive contaminants.

## 2.4 Location requirements

The unit should be placed in a upright position, inside or outside the dehumidified space, and be at least 15 cm above the floor.

The dehumidifier is intended for indoor installation.

It is important that the intended installation site meets the location and space requirements for the equipment in order to achieve the best possible performance and trouble-free operation.

For unit and service dimensions, *see section 6.3. Dimensions and service space.*



**WARNING!** *Do not place the Wet Air side (A) and the back side (B) of the unit close to the wall or close to heat sensitive objects. Position the dehumidifier so that there is sufficient space for the air to circulate around it.*

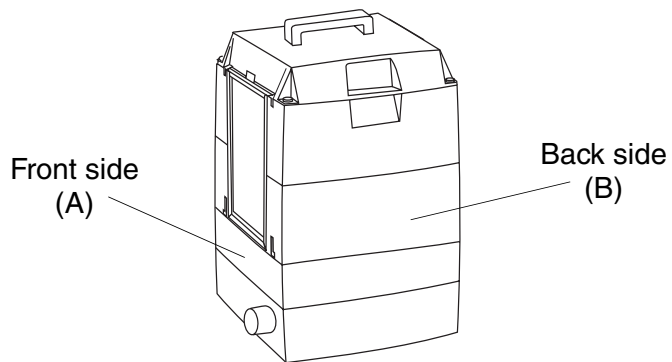

**NOTE!**

*It is important, both for maintenance and for service, that the minimum dimensions for service access are complied with.*

## 2.5 Duct/hose connections

### 2.5.1 General

Follow the instructions below when ducts, or alternate flexible hoses are attached to the unit's air outlet connections:

Process and reactivation air inlets and the dry air outlet can be connected to a duct system or operated with free suction and discharge. The wet air outlet however, must **always** be connected to a duct or hose which must be mounted so as to slope down from the dehumidifier to allow drainage of condensate.

- Ducting shall be as short as possible so as to minimize static pressure losses.
- For unrestricted performance, all duct connections must be air and vapour tight.



- Ducting for wet air shall be installed at a downward incline to enable condensate to drain. The wet air ducting should be provided with suitable drainage at low points to prevent the collection of condensed water. Alternatively, condensation can be avoided by insulating the duct with at least 25 mm of suitable insulating material.
- Cover the duct opening with a net to prevent birds and vermin from entering the unit. Place the duct opening so that rain and snow cannot enter the ducting.
- Ducting for wet air should be corrosion resistant and able to withstand temperatures of up to 70°C.
- The wet Air shall normally be transported outdoors. At large sites, where the dehumidifier is placed outside of the space to be dehumidified, the wet air can be discharged in the vicinity of the unit. Place the outlet so that wet air does not blow towards moisture-sensitive objects.
- The minimum distance between dry or wet air outlet and a wall is 0.5m.

The filters for both process and reactivation air can be changed with the ducting connected.



**CAUTION!** *If there is a risk of freezing temperatures, the wet air ducting must be insulated.*

## 2.5.2 Ducting and airflow adjustment

### Reactivation air

The dehumidifier is equipped with two orifice plates (airflow restrictions) in the reactivation air circuit.

One of which is located at the inlet to the reactivation air fan behind the filter and inlet cone (This cannot be removed).

The second orifice (**A**), is located in the wet air outlet. This orifice plate will provide correct airflow if a total of 5 m of hose is not exceeded for reactivation and wet air. If the flexible hose exceeds 5 m (max 10 m) the orifice plate (A) and wall pipe (optional extra) cannot be used.

When using a wall pipe (*see section 6.6. Accessories*) connected to the hose, remove orifice (A).

### Process air

The dry and process air hose may have a total length of up to 10 m without any significant effect on the dehumidifying capacity.

**Reduction of process airflow in a ventilating system** (*see figure 2-1. Connection to ducting*).

In order to obtain the required low humidity when the space is ventilated with dry air, (“open system”) the dry airflow should be reduced by fitting an orifice plate (**B**) inside the connection piece (**C**) for the dry air outlet. This will increase the dehumidification capacity.

The accessories (B) and (C) are optional extras. The connection piece (C) allows the dry air outlet to be duct connected.

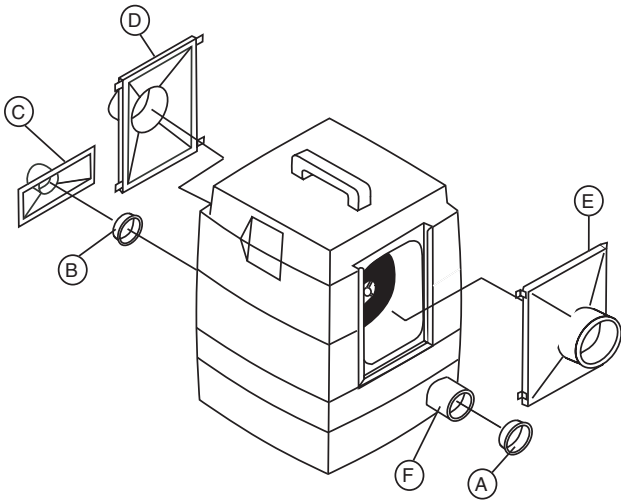

Item	Function
A <sup>1</sup>	Orifice plate for wet air.
B	Orifice plate used in a “ventilating system”.
C	Connection piece for dry air outlet.
D	Connection piece for process air inlet.
E	Connection piece for reactivation air inlet.
F	Wet air outlet.

<sup>1</sup> Item included with delivery  
Other items can be ordered as accessories, see section 6.6. Accessories.

Table 0-1. Duct Functions

Figure 2-1. Connection to ducting

## 2.6 Mounting units on the Wall

The MG units can be placed on the wall in two ways using a wall bracket (optional extra), thus enabling optimized positioning of the wet and dry air outlets to meet any desired requirements.

1. One is to have the unit’s wet air outlet positioned close to the wall on the right side of the unit.
2. The other is to have the front of the unit facing the wall, so that the wet air outlet is positioned furthest away from the wall to the left side of the unit.

Option 1 & 2 both have a strip of wood (or similar) placed inbetween the wall bracket and the wall. This wood is required so that to enable enough space for air to circulate around the units and to be able to connect the humidistat plug (option 2).

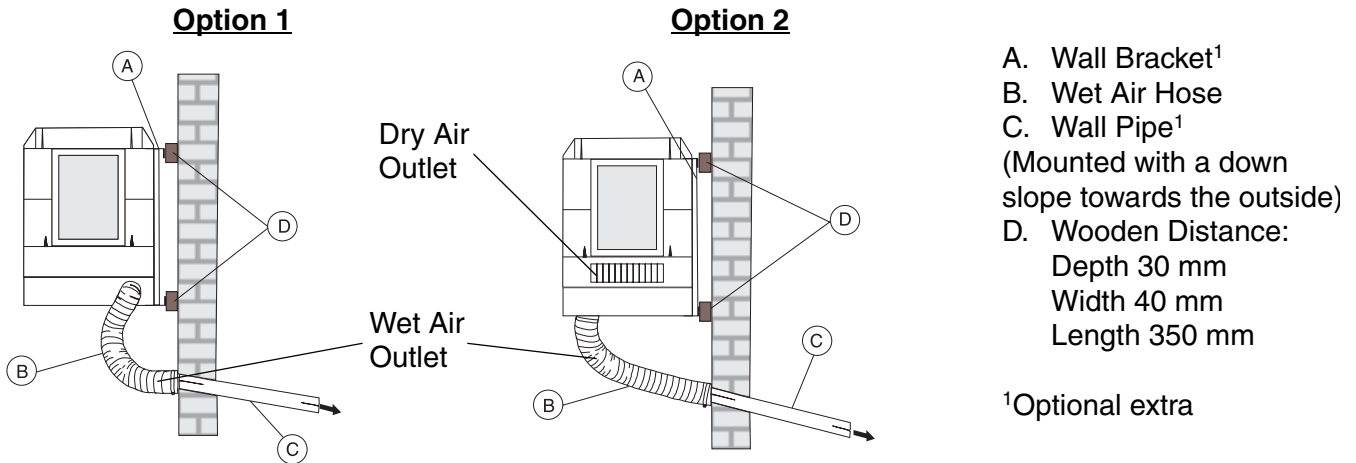

Figure 2-2. Wall mounted dehumidifiers.

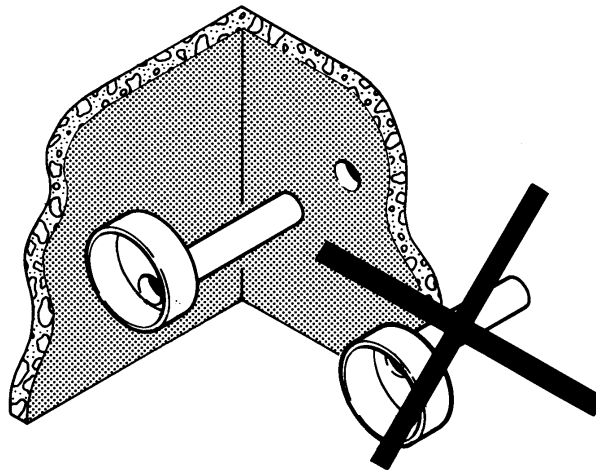

Figure 2-3. Wall Pipe

## 2.7 Installation examples

### Closed Airflow System

The air in the space is recirculated through the dehumidifier.

The wet air outlet is connected to a hose and is then discharged outside.

Reactivation air is taken from outside through a hose connected to a connection piece.

**NOTE!** A short hose (~ 0.3 m) on the dry air outlet can improve the air circulation and eliminate the risk of short-circuiting dry air and process air.

Process air is taken from the dehumidified space through a hose connected to a connection piece.

Dry air is supplied to the space through a hose connected to a connection piece. First remove the orifice plate (B) fitted in the connection piece.

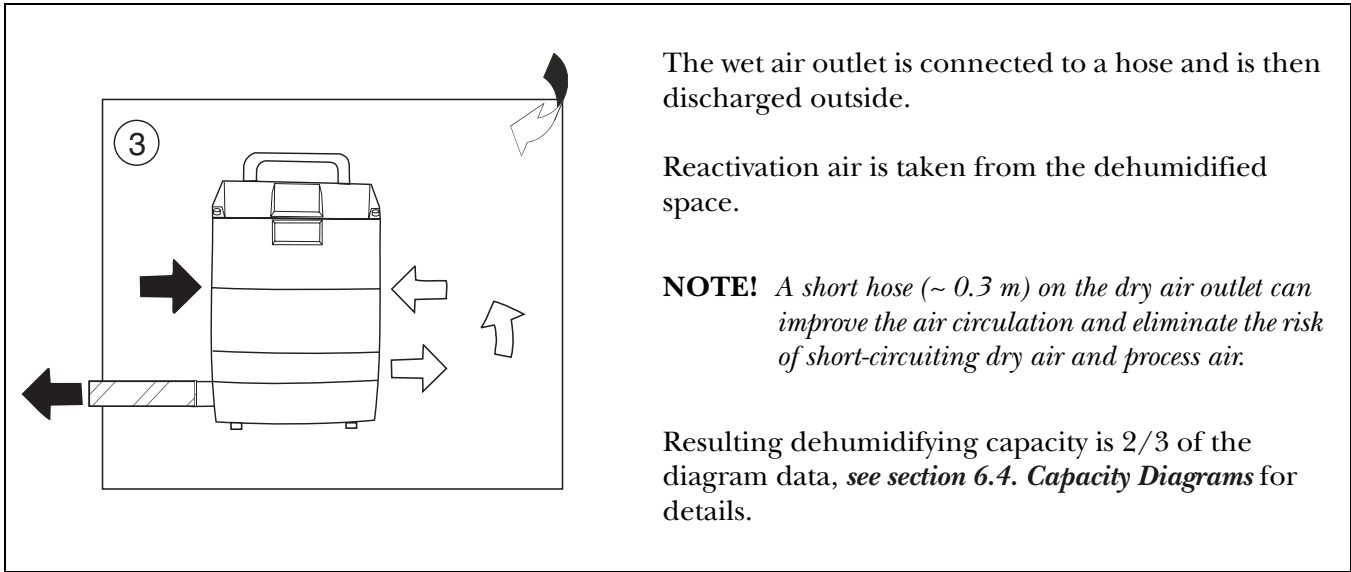
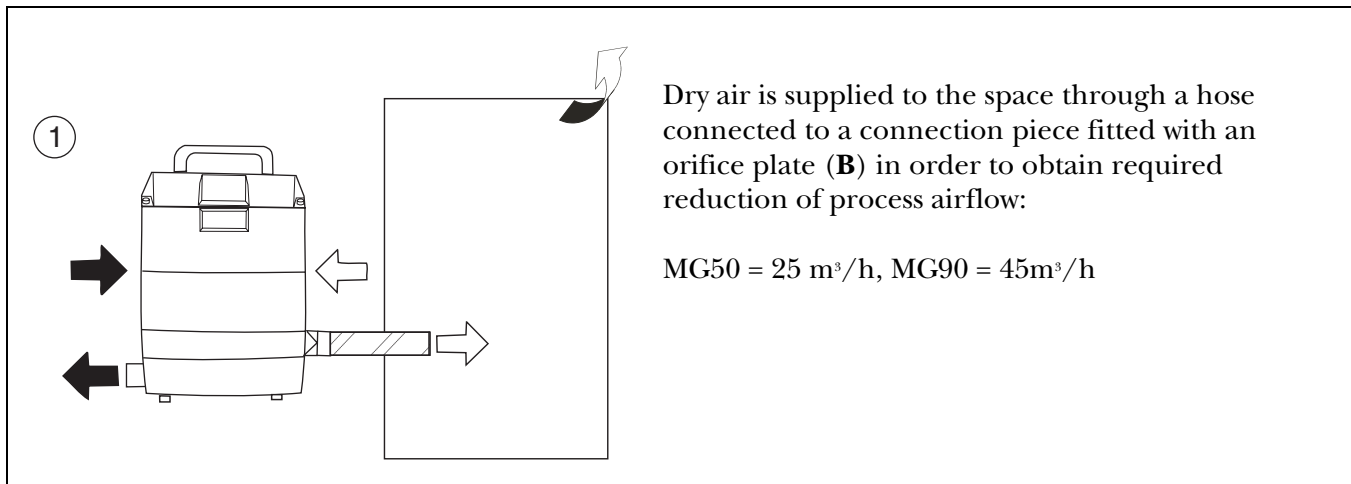

Figure 2-4. Installation examples in a closed system.

**Ventilating System**

The space is ventilated with dehumidified air.



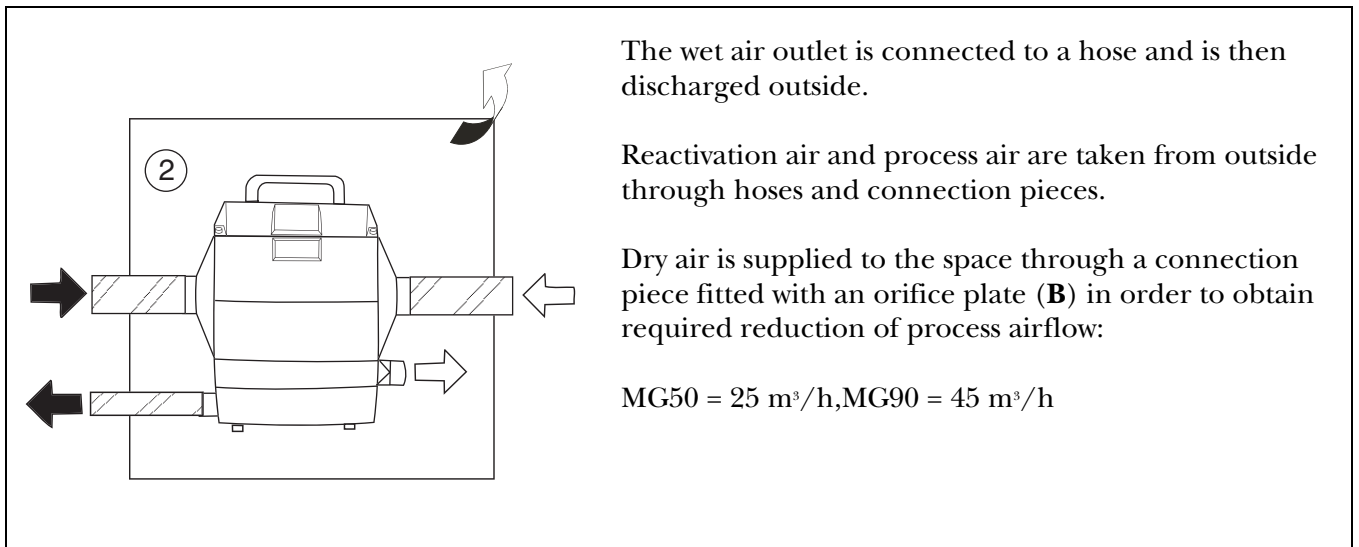

Figure 2-5. Installation examples in a ventilating system.

## 2.8 Electrical connections

### 2.8.1 General

Included with delivery is a 2.5m long power cable with a plug for connection to an earthed outlet. The voltage and frequency are specified on the unit's identification plate.

### 2.8.2 Safety



**WARNING!** The unit must be connected to an earthed electrical outlet.

**WARNING!** The unit must not be connected to other mains than specified on the unit's identification plate.

## 2.9 Connecting the humidistat

The dehumidifiers are supplied with a pre-wired socket, suitable for connecting the unit to a low voltage, single stage humidistat, see figure below. The humidistat can be ordered as an optional extra.

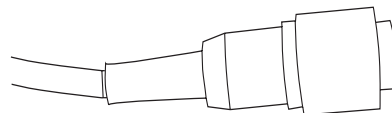

Figure 2-6. Humidistat Cable Connecting plug



**CAUTION!** We recommend that only a qualified electrician should connect the humidistat to the cable.

The connection socket for the humidistat is located on the front of the unit.

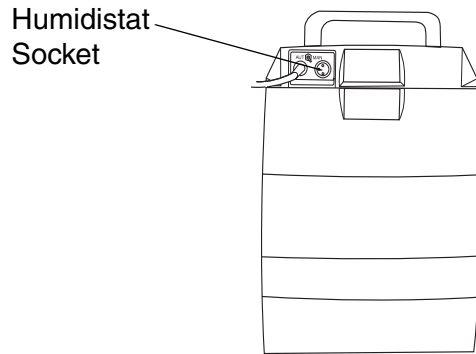

Figure 2-7. Humidistat Location

The humidistat should be mounted 1–1.5 m. above the floor and positioned so that it is not exposed directly to dry air from the unit or incoming moist air from opening and closing doors. It may not be placed close to a heat source or so that it is exposed to direct sunlight.

The humidistat shall be a single stage humidistat and connected so that the controlling circuit closes as relative humidity increases. The connecting cable shall be screened and have copper conductors with a minimum cross-section area of 2 x 0.75 mm<sup>2</sup>.

If the units are in conjunction with an external humidistat it can operate in either **A** or **B** mode.

**A mode:** The humidistat controls the entire dehumidifier ON/OFF (default mode).

**B mode:** The humidistat controls only the reactivation heater and the fan continuously operates ON/OFF.

At delivery the dehumidifier is connected to operate in the **A** mode.

To change the dehumidifier to **B** mode, move the link at S2 on the PCB from **A** to **B** as shown in figure 2-8. *PCB Board*.

For the location of the PCB, see figure 6-1. *Principal of operation*.



**WARNING!** All electrical equipment connections must be carried out in accordance with local regulations and by qualified personnel.

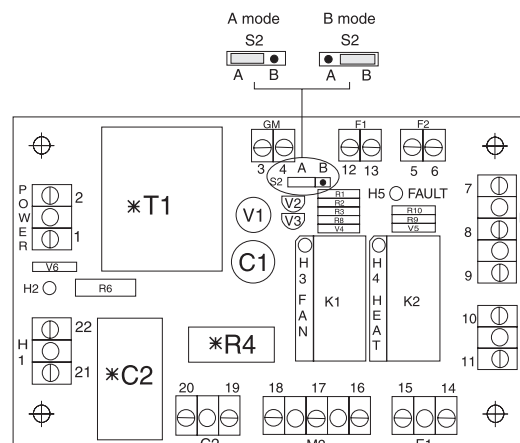

Figure 2-8. PCB Board

## 3. Operation

### 3.1 Starting up

Before starting the dehumidifier for the first time, carry out the following checks:

1. Check that the unit has been correctly connected to the mains supply, by reference to the identification plate (*see section 1.4. Markings*) and has been correctly connected to the supply. If a fused circuit breaker has been fitted, check that the fuse rating in the circuit breaker is correct.
2. If a humidistat has been installed, check that it has been correctly positioned in the room and has been properly connected to the unit (*see section 2.9. Connecting the humidistat*).

### 3.2 Emergency stop

Stop the unit by pulling out the plug from the wall outlet, or if it is permanently connected to the mains supply, by operating the externally mounted circuit breaker.

### 3.3 Start

#### 3.3.1 Manual operation

Set the mode switch to the **MAN** position and connect the dehumidifier to the mains supply or operate the circuit breaker (if fitted) and ensure that the unit starts.

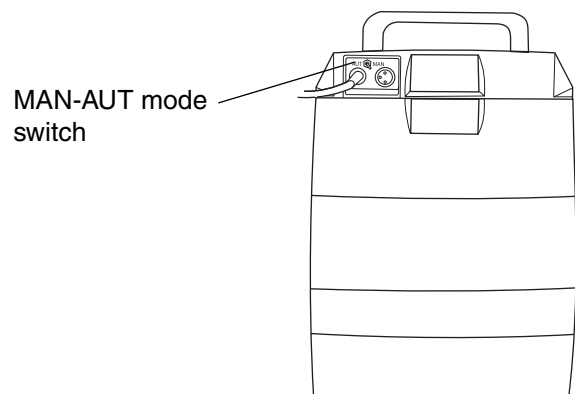

Figure 3-1. Location of MAN-AUT mode switch

#### 3.3.2 Automatic operation

**NOTE!**

*For the unit to operate in the Automatic Mode, an optional single-stage humidistat must be installed and correctly connect to the unit.*

1. Set the mode switch to the AUT position and adjust the humidistat set-point to the minimum relative humidity (RH) value.

2. Connect the dehumidifier to the mains supply or operate the circuit breaker (if fitted) and ensure that the unit starts.
3. Slowly increase the humidistat set-point until the dehumidifier stops. This checks that the humidistat and the dehumidifier are functioning correctly.

**NOTE!**

*Depending on the position of the link on the PCB, the fan may continue to run when the reactivation heater has been switched off. For details refer to section 2.9. Connecting the humidistat*

4. Adjust the humidistat set-point to the desired RH value.

### 3.4 Stopping the unit

Stop the unit by disconnecting it from the mains supply or by operating the externally mounted circuit breaker.



## 4. Maintenance

### 4.1 General

The dehumidifier is designed for long, continuous operation with minimum attention. Under normal operating conditions, requirements for maintenance are minimal.

Maintenance interval lengths are primarily determined by operating conditions and the environment in which the unit is installed. When in doubt, consult Munters' product service department. See addresses for Munters representatives on the back cover of this manual.

### 4.2 Safety



**WARNING!** *The unit must not be opened by anyone other than trained and qualified personnel.*

### 4.3 Maintenance schedule

The following maintenance schedule is recommended by Munters and covers procedures for inspection and maintenance as well as suggested time intervals for a unit that operates under normal operational and environmental conditions.

If the process air has a high dust content, preventative scheduled maintenance should be performed at shorter intervals than what is specified below.

Component	Inspection/Maintenance	
	3-6 Months	12 Months
Process and Reactivation filter	Clean filter <sup>1</sup> cassette and change filter as required.	Clean filter housing and change filter.
Unit housing	Check for physical damage and clean unit exterior if necessary.	Check for physical damage and clean unit exterior if necessary. If ducted, check connections for signs of air leaks and incorrect fitting.
Humidistat	N/A	Check sensor functions and calibrate or replace if necessary. Contact you local Munters's product service department as required.
Function and performance check.	N/A	Carry out a full function and performance check and replace worn components as necessary.

<sup>1</sup> When replacing the filter cassette, ensure that the arrow is pointing towards the dehumidifier.

*Table 4-1. Maintenance schedule*

## 5. Fault finding

### 5.1 General

The purpose of this chapter is to provide guidance in basic fault finding and provide instructions for corrective actions so as to remedy faults.

### 5.2 Safety



**WARNING!** *The unit must not be connected to other mains than specified on the units identification plate.*



**WARNING!** *The unit must not be opened by anyone other than trained and qualified personnel.*

### 5.3 Fault localization

Go through the following fault localization list below before contacting Munters' product service department. The list provides help in identifying types of faults that are easy to remedy without the assistance of specially trained personnel.

Fault Symptom	Possible Cause	Action
Unit has stopped.	Failure of the electrical supply.  Unit switched to automatic mode by mistake with no humidistat connected.  Humidistat fault (automatic mode).	Check power supply to the unit.  Set the operating mode to manual mode and check that the dehumidifier starts.  Set the operating mode to manual mode and check that the dehumidifier starts. If the unit starts, the humidistat is probably at fault.  Check the humidistat by seeing if the dehumidifier starts when the humidistat set-point is reduced. Reset the humidistat set-point after the check. Calibrate the humidistat if necessary or replace.
Unit has stopped.	The thermal protection in the fan motor has tripped.	<ul style="list-style-type: none"> <li>– Switch off the unit and disconnect it from the mains.</li> <li>– Remove the duct connection piece and filter cassette on the process and/or reactivation side.</li> <li>– Ensure that the fan impellers, that are now accessible, rotate freely.</li> </ul>
Unit has stopped.	High temperature cut-out has tripped.	Check that the filters and ducts are not blocked and reset the cut-out. To reset the cut-out the unit must be unplugged from the mains supply, then re-connected when the unit has cooled down.  The major causes of the high temperature cut-out tripping are: <ul style="list-style-type: none"> <li>– Reactivation airflow failure.</li> <li>– Blocked filter or duct.</li> <li>– Fan impeller obstructed.</li> </ul>
Loss of Performance:  Dehumidifier appears to be operating correctly, but is not controlling the humidity.	Reactivation temperature too low.  Reactivation heater not operating   Reactivation airflow is incorrect.   Rotor drive failure.	Check to see if orifice (A) is fitted.  Check that the reactivation heater is operating by measuring the power consumption, see table 6-4. Power specifications.  Check the ductwork (if fitted) and filters for blockages or signs of leaks. The usage of an orifice plate in conjunction with a wall pipe also causes too low reactivation airflow.  Check rotor drive belt and drive motor.  Check the rotor is rotating at about 10 revolutions per hour by looking through the dry air outlet.

Table 5-1. Fault localization

## 6. Product Design Information

### 6.1 Product description

The MG50 & MG90 desiccant dehumidifiers are designed to efficiently dehumidify air. Their very compact construction incorporates sections held together by four bolts. The fan, desiccant rotor and reactivation heater are secured in fixed positions within their respective sections without utilizing additional attachments. One of the sections contains a distribution chamber with isolated sections that provide precise balance for dehumidification and reactivation airflows. Its rugged casing is constructed from corrosion resistant die case aluminium.

The electrical control system conforms to EN 60204 (IEC204) standards and the electrical components are assembled in the upper compartment. MG Series dehumidifiers conform to both harmonised European Standards and to CE marking specifications.

### 6.2 Principal of operation

The unit's rotor is exposed in sectors to different airflows. The airflow that is to be dehumidified is called **process air** and passes through the largest sector of the rotor. The moisture in the process air is deposited into the rotor structure and the process air will then leave the rotor as **dry air**. While the rotor rotates slowly the incoming process air always meets a dry rotor structure, thus creating a continuous dehumidification process.

The desiccant rotor structure comprises of a large number of narrow and parallel air channels, processed to a composite material that is highly effective at attracting and holding water vapour.

The airflow that is used to reactivate (dry) the rotor structure is called **reactivation air** and is first heated. Passing through the smallest sector of the rotor, in the opposite direction to the process airflow, the reactivation air removes the deposited moisture and leaves the rotor as **wet air** (warm, moist air).

This method of operation means that the dehumidifier also works effectively at temperatures below 0°C.

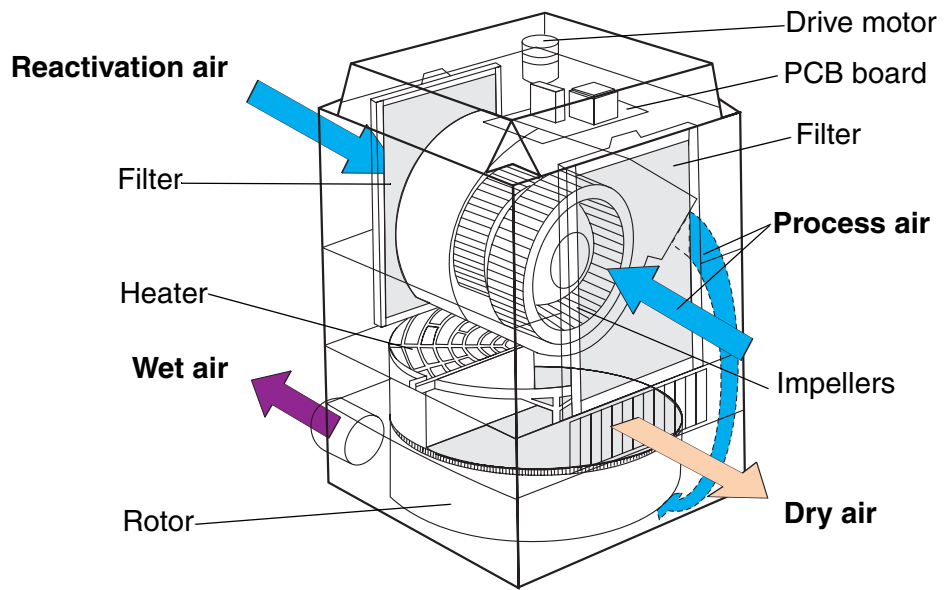

Figure 6-1. Principal of operation

### 6.3 Dimensions and service space

Scaled and dimensioned AutoCAD drawings are available in Munters' DryCAD program (can be ordered at the nearest Munters office).

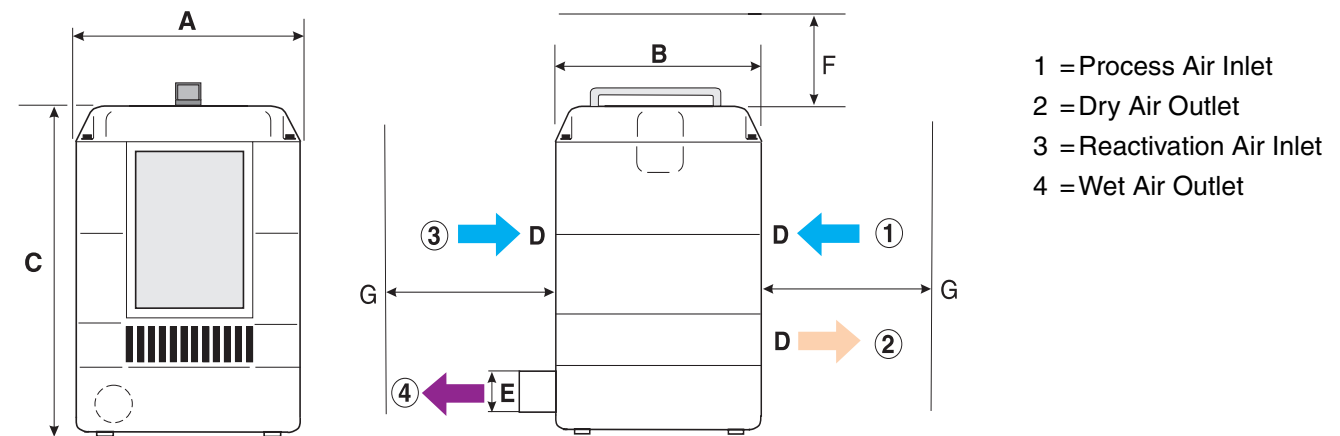

Figure 6-2. Dimensions

Width (A)	Depth (B)	Height (C)	Diameter <sup>1</sup> (D)	Diameter (E)	Service Space (F)	Service Space (G)	Weight
275 mm	275 mm	388 mm	62,5 mm	48 mm	350 mm	500 mm	10 kg

Table 6-1. Dimensions & Weight

<sup>1</sup> Connection piece accessory option.

**NOTE!**

The above dimensions & weight are for both the MG50 and the MG90 dehumidifiers.

### 6.4 Capacity Diagrams

Approximate capacity in kg/h.

For detailed information, please contact your nearest Munters office or refer to Munters' DryCap program.

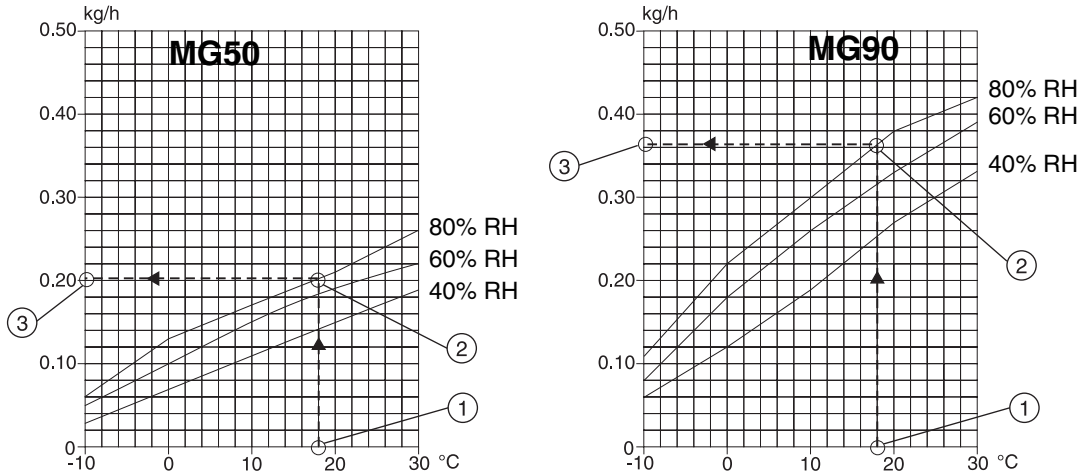

1. Process air temperature, °C
2. Process air relative humidity, %RH
3. Dehumidification capacity, kg/h (moisture removal kg/hour)

Figure 6-3. MG50 & MG90 Capacity diagrams, rated airflow

### 6.5 Fan Diagrams

The fan diagrams are for inlet conditions 20°C, density 1,2 kg/m<sup>3</sup>

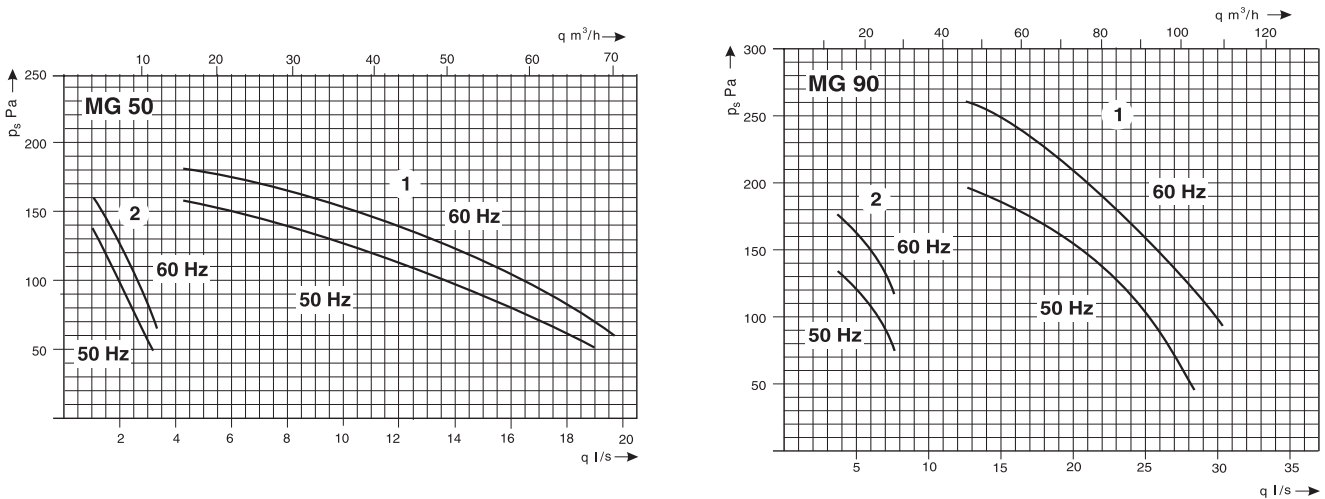

**Symbols:**

- q = Airflow, l/s (m<sup>3</sup>/h)
- p<sub>s</sub> = Static pressure available
- 1 = Process air
- 2 = Reactivation air. Without orifice plate on wet air outlet. <sup>(1)</sup>

<sup>(1)</sup> The dehumidifier is equipped with an orifice plate on the wet air outlet at delivery.

Figure 6-4. MG50 & MG90 Fan Diagrams

## 6.6 Accessories

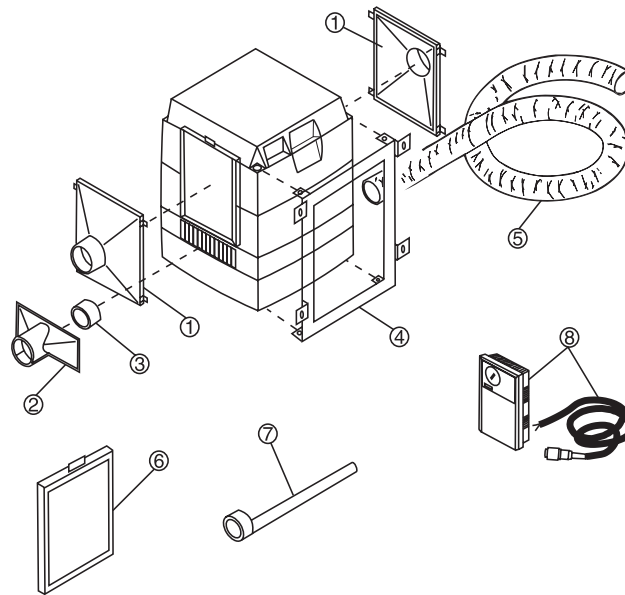

Figure 6-5. Accessory locations

Item	Accessory	Article No.
1	Connection piece for process air and reactivation air: Ø = 62,5 mm L = 70 mm	19026042
2	Connection piece for dry air: Ø = 62,5 mm L = 70 mm	19026044
3	Orifice plate to be used to obtain reduced airflow: MG50 (25 m³/h) MG90 (45 m³/h)	19030157 19030155
4	Wall Bracket	19026040
	Kits: Includes items 1,2,3 & 7 MG50 MG90	19030019 19030159
5	Hose for wet air: Ø = 51 mm Specify length in meters when ordering. <sup>2</sup> (1 m hose and 2 hose clamps are delivered with the dehumidifier)	19026043
6	<sup>2</sup> Filter Cassette	19030009
7	Wall pipe MG50: Outer Diameter Ø25 mm Wall pipe MG90: Outer Diameter Ø32mm	19026041 19030158
8	<sup>1</sup> Humidistat with cable and connection plug Humidistat	19026045E 19030042
<sup>1</sup> The humidistat cable is included with delivery <sup>2</sup> Included with delivery		

Table 6-2. Accessory details

## 6.7 Technical Specifications

Technical data for: Dehumidifier	Model:	
	MG50	MG90
<b>Process air<sup>1</sup></b>		
Freeblowing air 50Hz (m <sup>3</sup> /h)	80	110
Freeblowing air 60Hz (m <sup>3</sup> /h)	85	120
Rated airflow (m <sup>3</sup> /h)	50	90
Available static pressure 50Hz (Pa)	100	100
Available static pressure 60Hz (Pa)	120	120
Fan motor power (kW)	0,040	0,090
<b>Reactivation air<sup>1</sup></b>		
Rated airflow (m <sup>3</sup> /h)	12	20
Available static pressure (Pa)	50	100
Fan motor power (kW) <sup>2</sup>	-	-
<b>Reactivation air heater</b>		
Heater power (kW)	0,4	0,65
Temperature increase across heater (°C)	100	97
<b>Filter</b>		
Filter EU3 (Article No.)	19030009	19030009
<b>Miscellaneous data</b>		
Operating temperature (°C)	-20 to +40	-20 to +40
Drive motor power (W)	5	5
Max noise level unducted (dBa)	58	56
IEC protective class (unit)	IP44	IP44
IEC protective class (electrical panel)	IP54	IP54
Fan motor winding insulation grade	Class B	Class B
Drive motor winding insulation grade	Class B	Class B
Rotor type	HPS	HPS

<sup>1</sup> Stated performance based on 20 °C and air density of 1,2kg/m<sup>3</sup>.

<sup>2</sup> Common motor for process and reactivation fans.

Table 6-3. Technical specifications

Total power, voltage and current (amphs/phase)								
Unit	MG50				MG90			
<b>Voltage (V)</b>	115	200	230	240	115	200	230	240
<b>Frequency (Hz)</b>	50-60	50-60	50-60	50-60	50-60	50-60	50-60	50-60
<b>Total Power (W)</b>	440	440	440	440	740	740	740	740
<b>Current (A)</b>	3,8	2,2	1,9	1,8	6,4	3,7	3,2	3,1

Table 6-4. Power specifications











**AUSTRALIA**  
Munters Pty  
NORTH ALBURY  
Tel: +61 (0)260 256 422  
Fax: +61 (0)260 258 266

**AUSTRIA**  
Munters Luftentfeuchtung  
WIEN  
Tel: +43 1 616 42 98  
Fax: +43 1 616 42 98 98  
info@munters.co.at

**BELGIUM**  
Munters N.V.  
AARTSELAAR  
Tel: +32 3 458 24 34  
Fax: +32 3 458 24 33  
sales.info@muntersnv.be

**BRAZIL**  
Munters Brasil  
São Paulo  
Tel: +55 (0)11 505 40 150  
Fax: +55 (0)11 505 40 883

**CANADA**  
Munters Inc.  
MISSISSAUGA  
Tel: +1 905 858 5851  
Fax: +1 905 858 9130

**CHINA**  
Munters Beijing Ltd  
BEIJING  
Tel: +86 (0)10 80 481 121  
Fax: +86 (0)10 80 483 493

**DENMARK**  
Munters A/S  
FARUM  
Tel: +45 44 95 33 55  
Fax: +45 44 95 39 55  
info@munters.dk

**DUBAI**  
Munters Middle East  
DUBAI  
Tel: + 971 488 130 26  
Fax: + 971 488 131 06

**FINLAND**  
Munters OY  
HELSINKI  
Tel: +358 9 8386 030  
Fax: +358 9 8386 0336  
info@munters.fi

**FRANCE**  
Munters France SAS  
ARGENTEUIL  
Tel: +33 1 34 11 57 57  
Fax: +33 1 34 11 57 58  
dh@munters.fr

**GERMANY**  
Munters GmbH  
HAMBURG  
Tel: +49 40 734 16 01  
Fax: +49 40 734 11 11  
mgd@munters-mail.de

**ITALY**  
Munters S.R.L.  
ASSAGO (MI)  
Tel: +39 02 488 6781  
Fax: +39 02 488 1171  
info@munters.it

**JAPAN**  
Munters KK  
TOKYO 174  
Tel: +81 (0)3 5970 0021  
Fax: +81 (0)3 5970 3197

**KOREA**  
Munters  
SEOUL  
Tel: +82 (0)2 865 8771  
Fax: +82 (0)2 865 8737

**MEXICO**  
Munters de Mexico S.A. de C.V.  
APODACA, N.L.  
Tel: +52 81 8262 5400  
Fax: +52 818262 5401

**NETHERLANDS**  
Munters Vochtbeheersing  
ALPHEN a/d RIJN  
Tel: +31 172 43 32 31  
Fax: +31 172 44 29 60  
vochtbeheersing@munters.nl

**NEW ZEALAND**  
Munters Pty Ltd  
AUCKLAND  
Tel: +64 96 34 8241  
Fax: +64 96 34 8237

**POLAND**  
Munters Poland Sp zoo  
GDANSK  
Tel: +48 58 320 01 00  
Fax: +48 58 320 01 19  
dh@munters.pl

**SINGAPORE**  
Munters Pte Ltd  
SINGAPORE  
Tel: +65 6744 6828  
Fax: +65 6744 9585

**SOUTH AFRICA**  
Munters (Pty) Ltd  
JOHANNESBURG  
Tel: +27 (0)11 971 97 00  
Fax: +27 (0)11 971 97 25

**SPAIN**  
Munters Spain SA  
MADRID  
Tel: +34 91 640 09 02  
Fax: +34 91 640 11 32  
marketing@munters.es

**SWEDEN**  
Munters Europe AB  
SOLLENTUNA  
Tel: +46 8 626 6300  
Fax: +46 8 754 8594  
avfuktning@munters.se

**SWITZERLAND**  
Munters AG  
ZÜRICH  
Tel: +41 1 271 1013  
Fax: +41 1 271 1019  
munters.gl@gmx.ch

**THAILAND**  
Munters Co., Ltd  
BANGKOK  
Tel: +662 645 2708  
Fax: +662 645 2710

**UNITED KINGDOM**  
Munters UK Ltd  
HUNTINGDON  
Tel: +44 1480 432 243  
Fax: +44 1480 413 147  
info@munters.co.uk

**USA**  
Munters Corporation  
AMESBURY  
Tel: +1 978 241 1100  
Fax: +1 978 241 1214

[www.munters.com](http://www.munters.com)