

Air tools

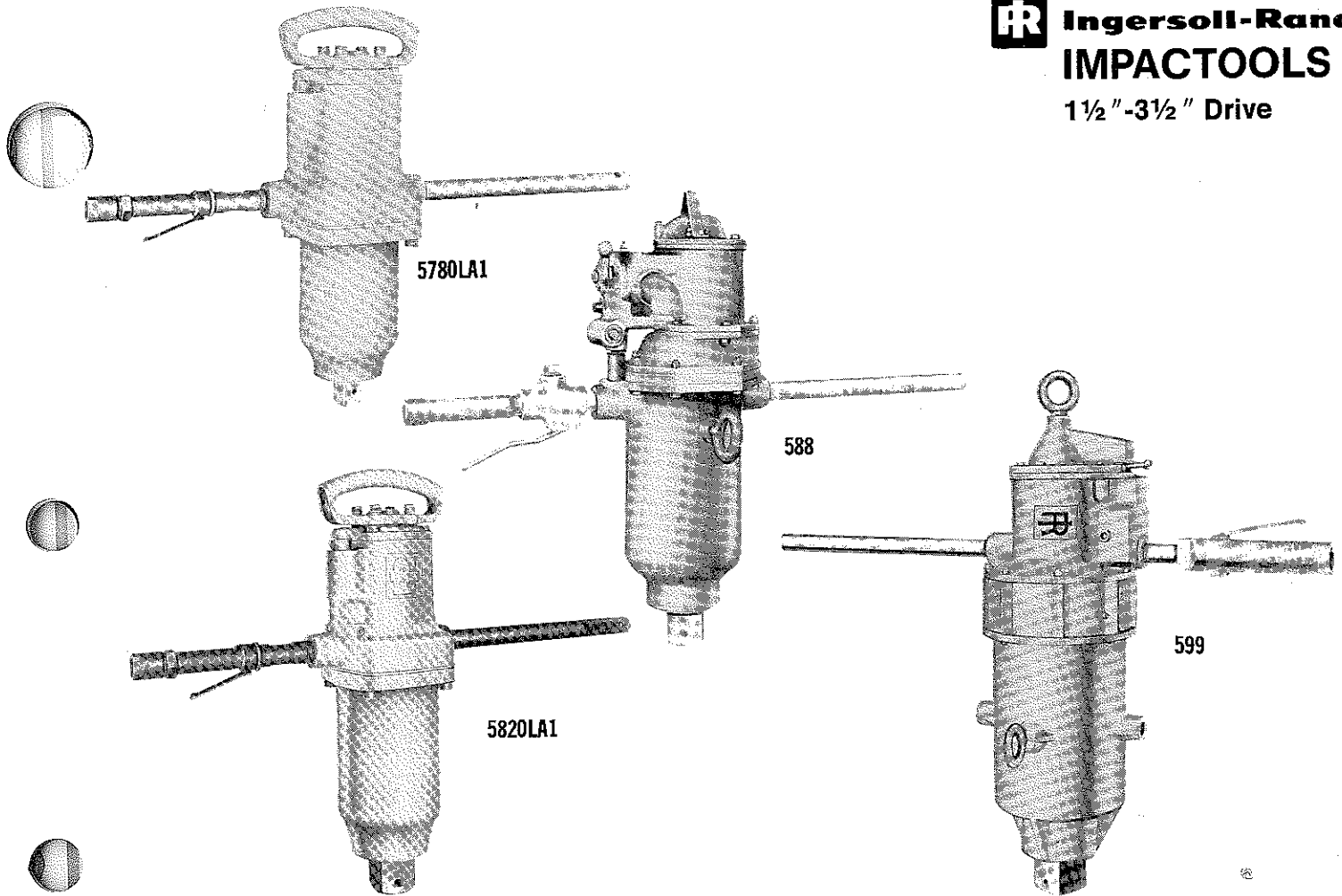

IR Ingersoll-Rand
IMPACTTOOLS
 1½" - 3½" Drive



SPECIFICATIONS—See pages 4 and 5 for specific bolt capacities.

Size	Driver Description	Handle	Hammer Case	Speed	Impacts	Weight, less socket		Length, less socket		Side to Center Distance		Hose Connection	Size Hose Recommended	
				rpm	per min	lb	kg	in.	mm	in.	mm	in.	in.	mm
5780LA1	1½" square	Lever	Alum.	830	1000	88	39.9	23	584	3⅛	78	¾	1	25
5780LA2	1½" square	Lever	Steel	830	1000	98	44.5	23	584	3⅛	78	¾	1	25
5820LA1	2½" square	Lever	Alum.	830	850	120	54.5	25⅞	645	3½	89	¾	1	25
588	2½" square	Lever	Malleable Iron	355	550	215	97.5	26⅞	676	4	101	1	1	25
599	3½" square	Lever	Ductile Iron	295	500	599	272	37½	952	6¾	171	1¼	1½	38

Performance figures are at 90 psi (620 kPa) air pressure
 Tools listed in **bold face type** are available from stock.

Equipment at Extra Price

Series 5780
 Eye Bolt (for vertical suspension) No. KU-888

Size 588
 Vertical Hanger consisting of:
 one Vertical Hanger No. 588-365A
 four Hanger Spacers No. 588-140

Eye Bolt (for horizontal suspension) No. 215-4

Size 5820LA1
 Eye Bolt (for vertical suspension) No. KU-888

Horizontal Hanger consisting of:
 one Horizontal Hanger No. 1LA582A1-366
 two Hanger Bolts No. R44H-490A
 two Lockwashers No. 34U-58
 two Nuts No. D02-428

Size 599
 Eye Bolt (total of three for either horizontal or vertical suspension) No. 22-104

Contact your Ingersoll-Rand air tool representative or distributor for complete information about other available accessories, or ask for Form 51150, Power Sockets and Attachments.