

L1058 Rev. B 08/01

#### 1.0 IMPORTANT RECEIVING INSTRUCTIONS

Visually inspect all components for shipping damage. Shipping damage is **not** covered by warranty. If shipping damage is found, notify carrier at once. The carrier is responsible for all repair and replacement costs resulting from damage in shipment.

#### SAFETY FIRST

#### 2.0 SAFETY ISSUES



Read all instructions, warnings and cautions carefully. Follow all safety precautions to avoid personal injury or property damage during system operation. Enerpac cannot be responsible for damage or injury resulting from unsafe product use, lack of maintenance or incorrect product and/or system operation. Contact Enerpac when in doubt as to the safety precautions and operations. If you have never been trained on high-pressure hydraulic safety, consult your distribution or service center for a free Enerpac Hydraulic safety course.

Failure to comply with the following cautions and warnings could cause equipment damage and personal injury.

A **CAUTION** is used to indicate correct operating or maintenance procedures and practices to prevent damage to, or destruction of equipment or other property.

A **WARNING** indicates a potential danger that requires correct procedures or practices to avoid personal injury.

A **DANGER** is only used when your action or lack of action may cause serious injury or even death.



**WARNING:** Wear proper personal protective gear when operating hydraulic equipment.



**WARNING: Stay clear of loads supported by hydraulics.** A cylinder, when used as a load lifting device, should never be used as a load holding device.

After the load has been raised or lowered, it must always be blocked mechanically.



**WARNING: USE ONLY RIGID PIECES TO HOLD LOADS.**

Carefully select steel or wood blocks that are capable of supporting the load. Never use a hydraulic cylinder as a shim or spacer in any lifting or pressing application



**DANGER:** To avoid personal injury keep hands and feet away from cylinder and workpiece during operation.



**WARNING:** Do not exceed equipment ratings. Never attempt to lift a load weighing more than the capacity of the cylinder. Overloading causes equipment failure and possible personal injury. The cylinders are designed for a max. pressure of 10,000 psi [700 bar]. Do not connect a jack or cylinder to a pump with a higher pressure rating.



**Never** set the relief valve to a higher pressure than the maximum rated pressure of the pump. Higher settings may result in equipment damage and/or personal injury.



**WARNING:** The system operating pressure must not exceed the pressure rating of the lowest rated component in the system. Install pressure gauges in the system to monitor operating pressure. It is your window to what is happening in the system.



**CAUTION:** Avoid damaging hydraulic hose. Avoid sharp bends and kinks when routing hydraulic hoses. Using a bent or kinked hose will cause severe back-pressure. Sharp bends and kinks will internally damage the hose leading to premature hose failure.



**Do not** drop heavy objects on hose. A sharp impact may cause internal damage to hose wire strands. Applying pressure to a damaged hose may cause it to rupture.



**IMPORTANT:** Do not lift hydraulic equipment by the hoses or swivel couplers. Use the carrying handle or other means of safe transport.



**CAUTION: Keep hydraulic equipment away from flames and heat.** Excessive heat will soften packings and seals, resulting in fluid leaks. Heat also weakens hose materials and packings. For optimum performance do not expose equipment to temperatures of 65°C [150°F] or higher. Protect hoses and cylinders from weld spatter.



**DANGER: Do not handle pressurized hoses.** Escaping oil under pressure can penetrate the skin, causing serious injury. If oil is injected under the skin, see a doctor immediately.



**WARNING:** Only use hydraulic cylinders in a coupled system. Never use a cylinder with unconnected couplers. If the cylinder becomes extremely overloaded, components can fail catastrophically causing severe personal injury.



**WARNING: BE SURE SETUP IS STABLE BEFORE LIFTING LOAD.** Cylinders should be placed on a flat surface that can support the load. Where applicable, use a cylinder base for added stability. Do not weld or otherwise modify the cylinder to attach a base or other support.



**Avoid** situations where loads are not directly centered on the cylinder plunger. Off-center loads produce considerable strain on cylinders and plungers. In addition, the load may slip or fall, causing potentially dangerous results.



Distribute the load evenly across the entire saddle surface. Always use a saddle to protect the plunger.



**IMPORTANT:** Hydraulic equipment must only be serviced by a qualified hydraulic technician. For repair service, contact the Authorized ENERPAC Service Center in your area. To protect your warranty, use only ENERPAC oil.



**WARNING:** Immediately replace worn or damaged parts by genuine ENERPAC parts. Standard grade parts will break causing personal injury and property damage. ENERPAC parts are designed to fit properly and withstand high loads.

### 3.0 GENERAL INFORMATION

The Enerpac valve design incorporates the following features into a single unit:

- 10,000 PSI Operating Pressure
- Load Holding
- Electrical Fail-safe Control
- Manual Override (VS-4, VSR4, VS424 only)
- The Enerpac valves are specifically designed for use with Enerpac electric powered pumps and electric controls.

#### 3.1 Capacity

Capacity is 1040 cubic inch per minute.

### 4.0 INSTALLATION

1. Connect and secure hoses and cylinder.
2. Connect control station.
3. Connect motor to specified electrical outlet.

#### NOTE:

- VS3, VSR3, VS4, VSR4 to be connected to 115 volts AC only.
  - VS324 to be connected to 24 volts AC only.
  - VS424 to be connected to 24 volts DC only.
4. Start pump motor. The valve is now automatically in the HOLD position.

**Note:** Both valves are fail-safe; if the control station is not actuated or the electrical supply to the valves is interrupted, the valve will automatically shift to the HOLD position, allowing the pump output to be directed to the tank and the cylinder load to be held. The 4-way valve can be operated manually by depressing the pin actuator at the proper end of the spool valve.

### 5.0 OPERATION

1. To advance load, depress "**P**" button on control station.
2. To hold load, remove finger from control station.
3. To retract load, depress "**R**" button on control station.

#### 5.1 Optional Automatic Return 3-way Valves Operation

The 3-way control valves can be converted into a dump valve. Conversion is done by replacing the control station supplied with the valve. A control station may be purchased separately, for 110 volt valves control station No. IC200 is required; for 24 volt valves control station No. IC224 is required.

### 6.0 MAINTENANCE

1. Periodically check all hydraulic connections to be sure they are tight. Loose or leaking connections may cause erratic and/or total loss of operation. Replace or repair all defective parts promptly.

2. Periodically check the hydraulic oil level in your system. Refer to the oil filling instructions for complete data.
3. Change hydraulic oil approximately every 250-300 hours of operation. In dusty or dirty areas, it may be necessary to change the oil more frequently.

### 7.0 HYDRAULIC SYSTEM

1. Keep all hydraulic components free of dirt, grease, chips, etc.
2. Keep the hydraulic component operating in areas that are uncluttered and free of unnecessary equipment.
3. Periodically check your hydraulic system for possible loose connections, leaks, etc. Replace or properly repair damaged or leaking hydraulic components immediately.
4. Check hydraulic oil in your hydraulic system every 40 hours of operation or more frequently in unusually dirty or dusty areas.

### 8.0 TROUBLESHOOTING

1. If the system will not build pressure, check relief valves in pump for proper setting (refer to pump repair sheet). Check and secure all hose connections. If trouble is not corrected by this action, remove cylinder and hoses from valve. Now place a 10,000 PSI gauge directly in valve port No. 1 (on 3-way valves, place gauge directly in valve port) and place the valve in ADV position. If pressure cannot be developed, the unit should be taken to the nearest ENERPAC authorized service center. If pressure develops, the problem is located in the cylinder, hoses, or couplers.
2. The cylinder will not load or the cylinder creeps when the valve is in the HOLD position. This is an indication of worn valve seats which must be replaced by a service center.
3. The cylinder is hung-up in either the ADV or RET position. This type of problem is usually a symptom of contaminated hydraulic oil. The system should be drained and refilled with fresh ENERPAC hydraulic fluid.
4. On the 4-way valve, center the spool valve manually by depressing the pin actuator on either end of the spool valve cover. Now press the ADV and RET buttons several times checking the valve operation and cylinder movement.

### 9.0 STORAGE INSTRUCTIONS

In the event that the unit would be stored for any prolonged period of time (30 days or more), prepare the unit as follows:

1. Wipe the entire unit clean.
2. Disconnect all hydraulic and electrical lines to prevent accidental operation.
3. Cover the unit with some kind of protective cover.
4. Store in a clean, dry environment that is NOT exposed to extreme temperatures.

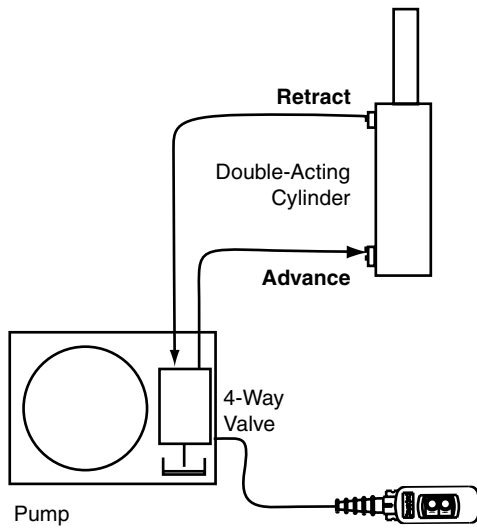
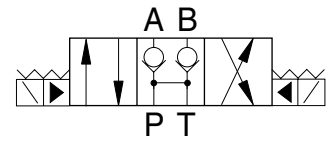
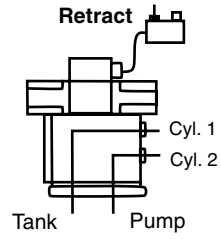
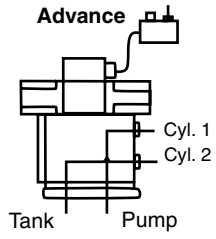
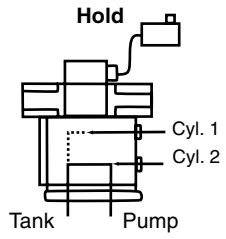

**4-Way Valve, Pump Mounted  
VS4, VS424**

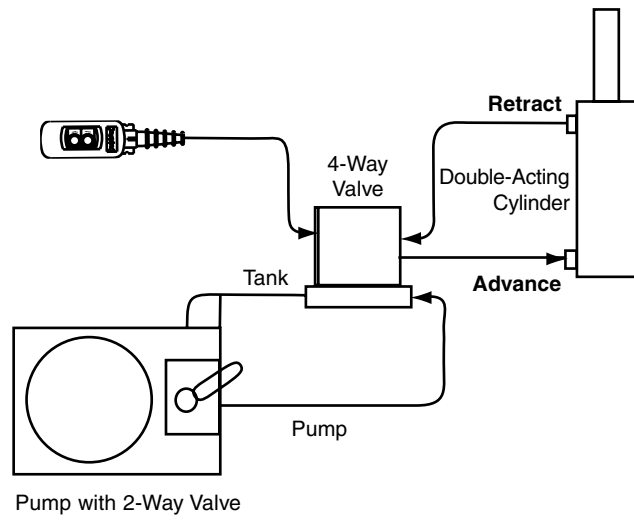

**4-Way Valve, Remote Mounted  
VSR4**

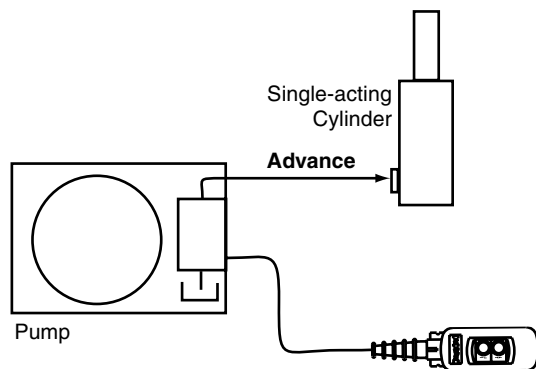
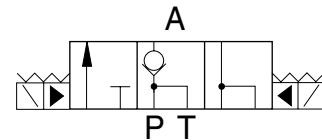
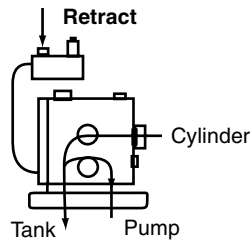
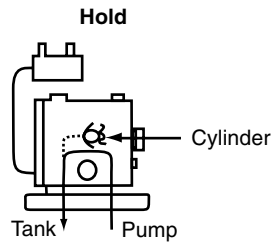
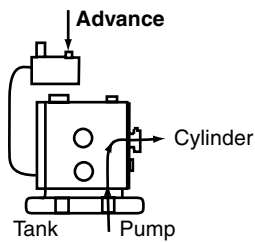

**3-Way Valve, Pump Mounted**  
**VS3, VS324**

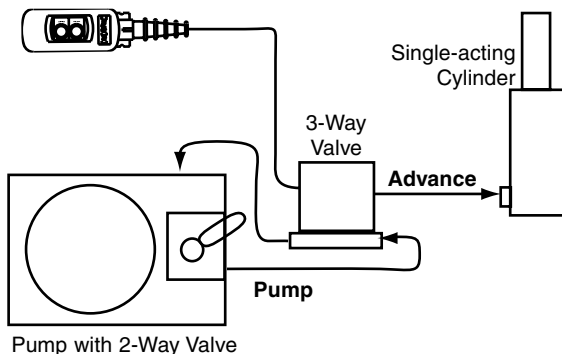

**3-Way Valve, Remote Mounted**  
**VSR3**

**Enerpac Worldwide Locations**

✦ e-mail: info@enerpac.com

✦ internet: www.enerpac.com

**Australia**

ENERPAC, Applied Power Australia Ltd.  
Block V Unit 3  
Regents Park Estate  
391 Park Road  
Regents Park NSW 2143  
(P.O. Box 261) Australia  
Tel: +61 297 438 988  
Fax: +61 297 438 648

**Canada**

Actuant Canada Corporation  
6615 Ordan Drive, Unit 14-15  
Mississauga, Ontario L5T 1X2  
Tel: +1 905 564 5749  
Fax: +1 905 564 0305

**Toll Free:**

Tel: +1 800 268 4987  
Fax: +1 800 461 2456

**China**

Applied Power China Ltd.  
1F, 269 Fute N. Road  
Waigaoqiao Free Trade Zone  
Pudong New District  
Shanghai, 200 131  
China  
Tel: +86 21 5866 9099  
Fax: +86 21 5866 7156

**France, Turkey, Greece,  
Africa, Middle East**

ENERPAC S.A.  
B.P. 200  
Parc d'Activités  
du Moulin de Massy  
F-91882 Massy CEDEX (Paris) France  
Tel: +33 1 601 368 68  
Fax: +33 1 692 037 50

**Germany, Switzerland,  
Austria, Eastern Europe**

ENERPAC  
Applied Power GmbH  
P.O. Box 300113  
D-40401 Düsseldorf  
Germany  
Tel: +49 211 471 490  
Fax: +49 211 471 49 28

**Hong Kong**

ENERPAC  
Room 907 Workingberg  
Commercial Building  
41-47 Marble Road  
North Point  
Tel: +852-2561 6295  
Fax: +852-2561 6772

**India**

ENERPAC  
Hydraulics (India) Pvt Ltd  
Plot No. A-571  
MIDC, TTC Industrial Area  
Mahape-400 701  
Navi Mumbai, India  
Tel: +91 22 769 47 78  
Fax: +91 22 769 84 73

**Italy**

ENERPAC  
Applied Power Italiana S.p.a.  
Via Canova 4  
20094 Corsico (Milano)  
Tel: +39 2 486 111 00  
Fax: +39 2 486 012 88

**Japan**

Applied Power Japan Ltd.  
1-1-11, Shimomae  
Toda-shi  
Saitama Pref.  
Japan 335-0016  
Tel: +81-48-430-2311  
Fax: +81-48-430-1117

**Mexico**

ENERPAC Applied Power  
Mexico S.A. de C.V.  
Avenida Principal  
La Paz #100  
Fracc. Industrial La Paz  
42092 Pachuca, Hidalgo  
Tel: +52 771 337 00  
Fax: +52 771 838 00

**The Netherlands, Belgium,  
Luxembourg, Sweden, Denmark,  
Norway, Finland, United Kingdom,  
Ireland**

ENERPAC B.V.  
Storkstraat 25  
P.O. Box 269, 3900 AG Veenendaal  
The Netherlands  
Tel: +31 318 535 911  
Fax: +31 318 525 613  
+31 318 535 848  
UK, Ireland  
Tel: +44 01527 598 900  
Fax: +44 01527 585 500

**Singapore**

Applied Power Asia Pte Ltd  
No. 8, Ang Mo Kio,  
Industrial Park 2  
#01-00  
Singapore 569500  
Thomson Road, P.O. Box 114  
Singapore 915704  
Tel: +65 484 5108  
Fax: +65 484 5669

**South Korea**

ENERPAC  
Applied Power Korea Ltd.  
163-12 Dodang-Dong  
Wonmi-Ku, Buchun-shi  
Kyunggi-Do  
Republic of Korea  
Tel: +82 32 675 08 36  
Fax: +82 32 675 30 02/73

**Spain, Portugal**

ENERPAC  
Applied Power International S.A.  
Avda. Camino de lo Cortao  
21 - Nave 3  
San Sebastian de los Reyes  
28709 Madrid  
Spain  
Tel: +34 91 661 11 25  
Fax: +34 91 661 47 89

**USA, Latin America  
and Caribbean**

ENERPAC  
P.O. Box 3241  
6101 N. Baker Road  
Milwaukee, WI 53209 USA  
Tel: +1 262 781 6600  
Fax: +1 262 781 1049

**User inquiries:**

+1 800 433 2766

**Distributor inquiries/orders:**

+1 800 558 0530

**All Enerpac products are guaranteed against defects in workmanship and materials for as long as you own them.  
For your nearest authorized Enerpac Service Center, visit us at [www.enerpac.com](http://www.enerpac.com)**